



Designation: C266 – 08^{ε1}

Standard Test Method for Time of Setting of Hydraulic-Cement Paste by Gillmore Needles¹

This standard is issued under the fixed designation C266; the number immediately following the designation indicates the year of original adoption or, in the case of revision, the year of last revision. A number in parentheses indicates the year of last reapproval. A superscript epsilon (ϵ) indicates an editorial change since the last revision or reapproval.

^{ε1} NOTE—Fig. 1 was corrected editorially in July 2011.

1. Scope*

1.1 This test method covers the determination of the time of setting of hydraulic-cement paste by means of the Gillmore needles.

1.2 The values stated in inch-pound units are to be regarded as standard. The values given in parentheses are mathematical conversions to SI units that are provided for information only and are not considered standard.

1.3 *This standard does not purport to address all of the safety concerns, if any, associated with its use. It is the responsibility of the user of this standard to establish appropriate safety and health practices and determine the applicability of regulatory limitations prior to use.*

Warning: Fresh hydraulic cementitious mixtures are caustic and may cause chemical burns to skin and tissue upon prolonged exposure. The use of gloves, protective clothing, and eye protection is recommended. Wash contact area with copious amounts of water after contact. Wash eyes for a minimum of 15 min. Avoid exposure of the body to clothing saturated with the liquid phase of the unhardened material. Remove contaminated clothing immediately after exposure.

1.4 The text of this standard references notes and footnotes which provide explanatory material. These notes and footnotes (excluding those in tables and figures) shall not be considered as requirements of the standard.

2. Referenced Documents

2.1 *ASTM Standards:*²

¹ This test method is under the jurisdiction of ASTM Committee C01 on Cement and is the direct responsibility of Subcommittee C01.30 on Time of Set

Current edition approved June 1, 2008. Published July 2008. Originally approved in 1951. Last previous edition approved in 2007 as C266–07. DOI: 10.1520/C0266-08.

² For referenced ASTM standards, visit the ASTM website, www.astm.org, or contact ASTM Customer Service at service@astm.org. For *Annual Book of ASTM Standards* volume information, refer to the standard's Document Summary page on the ASTM website.

C151 Test Method for Autoclave Expansion of Hydraulic Cement

C183 Practice for Sampling and the Amount of Testing of Hydraulic Cement

C187 Test Method for Amount of Water Required for Normal Consistency of Hydraulic Cement Paste

C219 Terminology Relating to Hydraulic Cement

C305 Practice for Mechanical Mixing of Hydraulic Cement Pastes and Mortars of Plastic Consistency

C511 Specification for Mixing Rooms, Moist Cabinets, Moist Rooms, and Water Storage Tanks Used in the Testing of Hydraulic Cements and Concretes

C670 Practice for Preparing Precision and Bias Statements for Test Methods for Construction Materials

C1005 Specification for Reference Masses and Devices for Determining Mass and Volume for Use in the Physical Testing of Hydraulic Cements

D1193 Specification for Reagent Water

3. Terminology

3.1 Refer to Terminology C219 for definitions of terms.

4. Summary of Test Method

4.1 Sufficient water is added to the cement that is being tested to produce a paste of normal consistency. A specimen is molded from this paste and is tested for time of setting by means of the Gillmore initial and final needles. The initial time of setting is the time elapsed between initial contact of cement and water and the time when the Gillmore Initial needle does not leave a complete circular impression in the paste surface. The final time of setting is the time elapsed between initial contact of cement and water and the time when the Gillmore Final needle does not leave a complete circular impression in the paste surface.

5. Significance and Use

5.1 The purpose of this test method is to establish whether a cement complies with a specification limit on Gillmore time of setting.

*A Summary of Changes section appears at the end of this standard

Cement Paste Pat
 Base diameter 76 ± 13 mm
 (3 ± 0.5 in.)
 Top diameter 50 ± 13 mm
 (2 ± 0.5 in.)
 Center thickness 13 ± 3 mm
 (0.5 ± 0.125 in.)

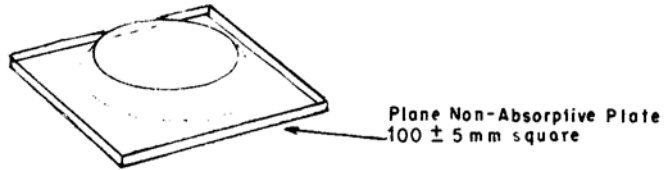

(a) Pat with Top Surface Flattened for Determining Time of Setting by Gillmore Method

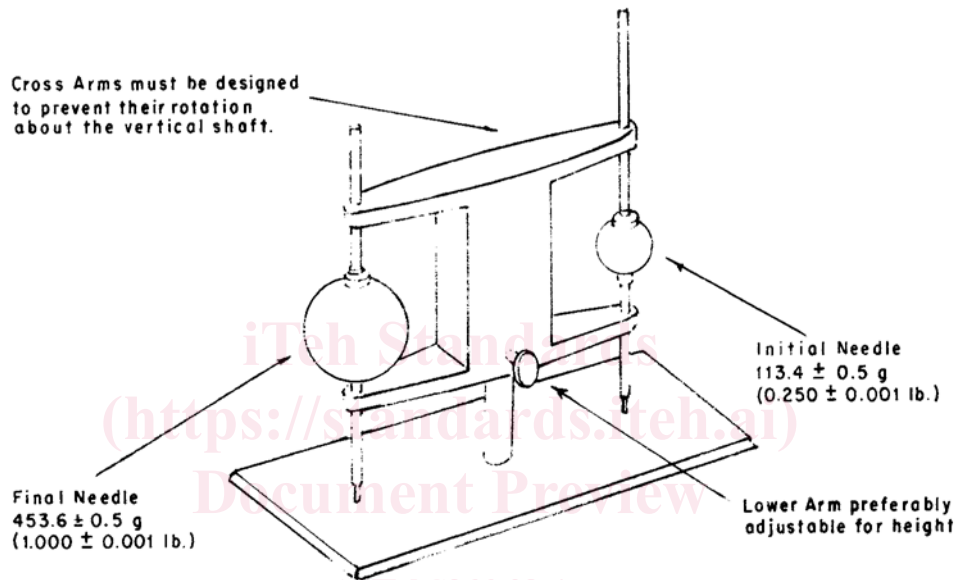

ASTM C266-08e1

<https://standards.iteh.ai/catalog/standards/sist/2a172d59-06e9-4ebf-b919-be027a83bacb/astm-c266-08e1>

(b) Gillmore Apparatus

Replaceable tips may be made of stock drill rod or wire tempered after shaping and held by suitable chuck or other fastener

Tip Diameter
 Initial: 2.12 ± 0.05 mm
 (0.084 ± 0.002 in.)
 Final: 1.06 ± 0.05 mm
 (0.042 ± 0.002 in.)

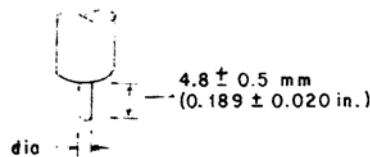

(c) Detail of Gillmore Apparatus Needle Tips

FIG. 1 Gillmore Apparatus and Test Specimen