



Designation: E215-98 (Reapproved 2004)^{ε1} Designation: E215 - 11

Standard Practice for Standardizing Equipment for Electromagnetic Examination Testing of Seamless Aluminum-Alloy Tube¹

This standard is issued under the fixed designation E215; the number immediately following the designation indicates the year of original adoption or, in the case of revision, the year of last revision. A number in parentheses indicates the year of last reapproval. A superscript epsilon (ϵ) indicates an editorial change since the last revision or reapproval.

This specification has been approved for use by agencies of the Department of Defense.

~~^{ε1}Note—Reapproved with editorial changes throughout in January 2004.~~

1. Scope*

1.1 This practice² is intended as a guide for standardizing eddy-current equipment employed in the examination of seamless aluminum-alloy tube. Artificial discontinuities consisting of flat-bottomed or through holes, or both, are employed as the means of standardizing the eddy-current system. General requirements for eddy-current examination procedures are included.

1.2 Procedures for fabrication of reference standards are given in Appendixes X1.1 and X2.1.

1.3 This practice is intended for the examination of tubular products having nominal diameters up to 4 in. [101.6 mm] and wall thicknesses up to the standard depth of penetration (SDP) of eddy currents for the particular alloy (conductivity) being examined and the examination frequency being used.

NOTE 1—This practice may also be used for larger diameters or heavier walls up to the effective depth of penetration (EDP) of eddy currents as specified by the using party or parties.

~~1.4 The values stated in inch-pound units are to be regarded as the standard.~~

~~1.5 This practice does not establish acceptance criteria. They must be established by the using party or parties.~~

1.4 This practice does not establish acceptance criteria. They must be established by the using party or parties.

1.5 The values stated in inch-pound units are to be regarded as the standard. The values given in parentheses are mathematical conversions to SI units that are provided for information only and are not considered standard.

1.6 *This standard does not purport to address all of the safety problems, if any, associated with its use. It is the responsibility of the user of this standard to establish appropriate safety and health practices and determine the applicability of regulatory limitations prior to use.*

2. Referenced Documents

2.1 *ASTM Standards:*³

E543 [Specification for Agencies Performing Nondestructive Testing](#)

E1316 [Terminology for Nondestructive Examinations](#)

2.2 *Federal Standard:*

Fed Std. No. 245D [Tolerance for Aluminum Alloy and Magnesium Alloy Wrought Products](#)⁴

2.3 *Other Documents:*

SNT-TC-1A [Recommended Practice for Personnel Qualification and Certification in Nondestructive Testing](#)⁵

ANSI/ASNT-CP-189 [ASNT Standard for Qualification and Certification of Nondestructive Testing Personnel](#)⁵

¹ This practice is under the jurisdiction of ASTM Committee E07 on Nondestructive Testing and is the direct responsibility of Subcommittee E07.07 on Electromagnetic Methods.

Current edition approved January 1, 2004. Published February 2004. Originally approved in 1963. Last previous edition approved in 1998 as E215-98. DOI: 10.1520/E0215-98R04E01 on Electromagnetic Method.

Current edition approved July 1, 2011. Published July 2011. Originally approved in 1963. Last previous edition approved in 2004 as E215-98(2004) ^{ε1}. DOI: 10.1520/E0215-11.

² For ASME Boiler and Pressure Vessel Code applications see related Practice SE-215 in the Code.

³ For referenced ASTM standards, visit the ASTM website, www.astm.org, or contact ASTM Customer Service at service@astm.org. For *Annual Book of ASTM Standards* volume information, refer to the standard's Document Summary page on the ASTM website.

⁴ Available from Standardization Documents Order Desk, DODSSP, Bldg. 4, Section D, 700 Robbins Ave., Philadelphia, PA 19111-5094, Attn: NPODS; 19111-5098, <http://dodssp.daps.dla.mil>.

⁵ Available from The American Society for Nondestructive Testing (ASNT), P.O. Box 28518, 1711 Arlingate Ln., Columbus, OH 43228-0518, <http://www.asnt.org>.

*A Summary of Changes section appears at the end of this standard.

3. Terminology

3.1 ~~Standard terminology relating to electromagnetic examination may be found in Terminology~~

3.1 Definitions—For definitions of terms used in this practice, refer to Terminology E1316, Section C, Electromagnetic Testing.

4. Significance and Use

4.1 The examination is performed by passing the tube lengthwise through or near an eddy current sensor energized with alternating current of one or more frequencies. The electrical impedance of the eddy current sensor is modified by the proximity of the tube. The extent of this modification is determined by the distance between the eddy current sensor and the tube, the dimensions, and electrical conductivity of the tube. The presence of metallurgical or mechanical discontinuities in the tube will alter the apparent impedance of the eddy current sensor. During passage of the tube, the changes in eddy current sensor characteristics caused by localized differences in the tube produce electrical signals which are amplified and modified to actuate either an audio or visual signalling device or a mechanical marker to indicate the position of discontinuities in the tube length. Signals can be produced by discontinuities located either on the external or internal surface of the tube or by discontinuities totally contained within the tube wall.

4.2 The depth of penetration of eddy currents in the tube wall is influenced by the conductivity (alloy) of the material being examined and the excitation frequency employed. As defined by the standard depth of penetration equation, the eddy-current penetration depth is inversely related to conductivity and excitation frequency (Note 2). Beyond one standard depth of penetration (SDP), the capacity to detect discontinuities by eddy currents is reduced. Electromagnetic examination of seamless aluminum alloy tube is most effective when the wall thickness does not exceed the SDP or in heavier tube walls when discontinuities of interest are within one SDP. The limit for detecting metallurgical or mechanical discontinuities by way of conventional eddy current sensors is generally accepted to be approximately three times the SDP point and is referred to as the effective depth of penetration (EDP).

NOTE 2—The standard depth of penetration is defined by the following equations:

$$SDP = 503.3 \sqrt{\frac{1}{f\sigma}}$$

where:

SDP = one standard depth of penetration, m

f = frequency, Hz (cycles per second), and

σ = conductivity, siemens-metre/mm²; conductivity, Siemens/metre.¹

or: <https://standards.iteh.ai/catalog/standards/sist/273fdcca-0b42-4eda-8bf8-df2f52d3348d/astm-e215-11>

$$SDP = 26 \sqrt{\frac{1}{f\sigma}}$$

where:

SDP = one standard depth of penetration, inches

f = frequency in Hz (cycles per second), and

σ = conductivity, % IACS.

5. Basis of Application

5.1 If specified in the contractual agreement, personnel performing examinations to this practice shall be qualified in accordance with a nationally recognized NDT personnel qualification practice or standard such as ANSI/ASNT-CP-189, SNT-TC-1A, MIL-STD-410, NAS-410, or a similar document and certified by the certifying agency's as applicable. The practice or standard used and its applicable revision shall be ~~identified~~specified in the contractual agreement between the using parties.

NOTE 3—MIL-STD-410 is canceled and has been replaced with NAS-410, however, it may be used with agreement between contracting parties.

5.2 If specified in the contractual agreement, NDT agencies shall be qualified and evaluated in accordance with Practice Specification E543. The applicable edition of Practice Specification E543 shall be specified in the contractual agreement.

6. Apparatus

6.1 Electronic Apparatus—The electronic apparatus shall be capable of energizing eddy current sensors with alternating

⁶ Available from Aerospace Industries Association of America, Inc., 1250 Eye Street, N.W., Washington, DC 20005.

⁶ Available from Aerospace Industries Association of America, Inc. (AIA), 1000 Wilson Blvd., Suite 1700, Arlington, VA 22209-3928, <http://www.aia-aerospace.org>.

currents of suitable frequencies and shall be capable of sensing the changes in the electromagnetic characteristics of the eddy current sensors. Equipment may include a detector, phase discriminator, filter circuits, gating circuits, and signalling devices as required for the particular application.

6.2 *Eddy Current Sensors*—Eddy current sensors shall be capable of inducing currents in the tube and sensing changes in the electrical characteristics of the tube. The eddy current sensors may be of the encircling coil (annular) type or surface probe type.

7. Standardization of Apparatus

7.1 The apparatus shall be adjusted with an appropriate reference standard to ensure that the equipment is operating at the proper level of sensitivity, with the following considerations:

7.1.1 Primary reference standards employed for this purpose shall be prepared in accordance with the methods described in Appendix X1.1.

7.1.2 Equivalent secondary reference standards, prepared in accordance with methods described in Appendix X2.1, also may be employed for standardizing the apparatus.

7.1.3 Reference standards normally are of the same alloy, temper, and dimensions as the tube to be examined.

7.1.4 Examinations shall not be conducted unless the equipment can be set to the levels required by this standardization procedure.

7.1.5 For practical applications, reference standards also may be employed to establish quality control levels.

8. Procedure

8.1 Standardize the examination instrument using the appropriate reference standard prior to examination and check at least every 4 h during continuous operation, or whenever improper functioning of the examination apparatus is suspected. If improper functioning occurs, restandardize the apparatus in accordance with Section 7, and reexamine all tubes examined since the last successful standardization.

8.2 Tubes may be examined in the final drawn, annealed, or heat-treated temper, or in the drawn temper prior to the final anneal or heat treatment.

8.3 The length of tube over which end effect is significant may be determined by placing a series of holes or notches in special reference tubes and determining the distance from the tube end at which the signal amplitude from the discontinuities begins to decrease.

8.3.1 When standardizing and testing using secondary standard Method B (X2.5.2), if full length testing is required, the tube must be ordered to be electromagnetic tested in a rough cut length and have the untested 7 in. (175 mm) removed from each end.

NOTE 4—There is an area near each end which cannot be tested either because of an alarm from end effect or because end suppression is used to eliminate an alarm from end effect. Up to 7 in. (175 mm) on each end is to be considered untested, regardless of the standard used. Customers must specify if they want these untested areas removed.

9. Application

9.1 This application covers the electromagnetic examination of aluminum-alloy seamless tube using primary and secondary reference standards.

9.2 Primary and secondary reference standards, described in Appendixes X1.1 and X2.1, respectively, when used as acceptance standards, will establish probable detection of defects that are of a severity likely to cause leaks or substantial weakening of the tube.

9.3 Using electronic apparatus and eddy current sensors described in Section 6, the equipment sensitivity shall be standardized in accordance with Section 7 under the following examination conditions:

9.3.1 *Frequency*—The frequency shall be in the range from 1 to 125 kHz. The examination frequency should be adjusted to provide optimum penetration of the tube wall or to place discontinuities of interest within one SDP. Discontinuities located deeper than the SDP point will be detected with less sensitivity. The SDP point will vary as a function of the tube alloy (conductivity) and examination frequency and may be determined by the depth of penetration equation given in Section 4, Note 2.

9.3.2 *Speed of Examination*—The examination rate, or speed of the tube with respect to the eddy current sensor, may vary with the application. In encircling coil applications, examination speeds of ~~15.2 m/min [50 fpm]~~ 50 ft/min (15 m/min) to ~~152 m/min [500 fpm]~~ 500 ft/min (150 m/min) are recommended where possible, but examination speeds as high as ~~305 m/min [1000 fpm]~~ 1000 ft/min (300 m/min) are permissible. In surface probe applications, examination speeds are inherently slower due to reduced surface coverage and the necessity to rotate the eddy current sensor or the tube to produce a helical scan. All instrument adjustments, that is, frequency, phase setting, filter setting, sensitivity setting, threshold-level setting, etc., shall be made with the reference standard or acceptance standard or both passing through or by the eddy current sensor at the same speed at which the examination of tube is to be conducted.

9.3.3 *Phase Setting*—The phase setting should be selected to provide the best signal-to-noise ratio for the reference standard employed, that is, the maximum ratio of indication height from the appropriate artificial discontinuities to the indication height from non-detrimental discontinuities.

9.3.4 *Filter Setting*—The filter setting should be selected commensurate with the examination speed to provide optimum filtering of non-detrimental, time-varying discontinuities such as geometry, pathline variation, high-frequency noise, etc.

9.3.5 *Sensitivity Setting*—The sensitivity setting shall be adjusted to provide clearly discernible indications of a convenient height for the appropriate accept holes (A or d_a), but it shall not be high enough to cause off-scale or saturated indications for the appropriate reject holes ($2A$ or d_b) of the reference standard.

9.3.6 *Threshold-Level Setting*—The threshold-level setting (reject level) shall be adjusted to automatically trigger an audio or visual-signalling device or a mechanical marker when the appropriate artificial discontinuity (or discontinuities) of the acceptance standard passes through or by the eddy current sensor.

~~9.4 When using reference standards as acceptance standards the threshold level should be adjusted to accept tubes exhibiting eddy-current responses smaller than those obtained from the appropriate reject holes (2~~

9.4 Using Reference Standards as Acceptance Standards:

9.4.1 Method A (X2.1) Reference Standards: When using reference standards as acceptance standards the threshold level should be adjusted to accept tubes exhibiting eddy-current responses smaller than those obtained from the appropriate reject holes ($2A$ or d_b) and to reject those with responses equivalent to or greater than those obtained from the appropriate reject holes ($2A$ or d_b) in the reference standard. Experience shows that this procedure will aid in the rejection of severe defects and, at the same time, minimize erroneous rejection of tubes that might exhibit noise from non-detrimental discontinuities.

9.4.2 Method B (X2.2) Reference Standard Selection: Reference standards selected for use must be the same alloy, temper, diameter, and wall thickness as the material being tested. The reference standard selected for use must contain the proper size reject holes and must have been fabricated and identified in accordance with this procedure.

9.4.2.1 When using reference standards as acceptance standards the threshold level should be adjusted as required in X2.5.2.2. Tubes that do not exceed the alarm limits established by the reference standard shall be considered as acceptable under this method.

10. Keywords

10.1 aluminum alloy; eddy currents; electromagnetic examination; equipment standardization; NDT; nondestructive testing; tubing

APPENDIXES

(Nonmandatory Information)

X1. PURPOSE, DESCRIPTION, FABRICATION, AND CHECKING OF PRIMARY REFERENCE STANDARDS

X1.1 Purpose

X1.1.1 Primary reference standards are used to standardize examination equipment under operating conditions to establish acceptable limits of sensitivity, reproducibility, and capability for detecting defects of a severity likely to cause leaks or substantial weakening of the tube.

X1.1.2 The dimensions of the appropriate primary reference standard are determined by the size of the tube to be examined. A primary reference standard shall be a tube of the same alloy, temper, outside diameter, D , and wall thickness, t , as the tube to be examined. This appendix covers the preparation of primary standards for test of seamless aluminum-alloy tube.

X1.2 Description

X1.2.1 The primary reference standard shall contain six artificial discontinuities in the form of flat-bottomed drilled holes in a ~~183-cm [6-ft]~~ 180-cm length of tube which is free of significant natural discontinuities. Fig. X1.1 describes the primary reference standard for aluminum-alloy seamless tube.

X1.2.2 The six flat-bottomed holes shall be of equal diameter, d , and shall be located in the mid-portion of the tube. The distance between adjacent holes is ~~152-mm [6-in.]~~ 150 mm. The minimum distance between a hole and either end of the tube shall be approximately ~~500-mm [20-in.]~~ 500 mm.

X1.2.3 Three of each of the reference standard holes A and $2A$ shall be drilled consecutively to depths of one third and two thirds the wall thickness, respectively in radial longitudinal planes $120 \pm 5^\circ$ apart.

X1.2.4 The diameter, d , of the flat-bottomed drill used to make a primary reference standard hole shall be determined mathematically with the following equation:

$$d = k (Dt) \times 10^{-3} \quad (X1.1)$$

where:

d = drill diameter of ~~A and 2A flat-bottom holes, mm [in.]~~ flat-bottom holes, in. (mm),

k = ~~76.2 mm [3 in.]~~ 3.0 in. (76 mm),

D = ~~tube outside diameter, mm [in.]~~ and tube outside diameter, in. (mm), and

t = ~~tube wall thickness, mm [in.]~~ tube wall thickness, in. (mm).

X1.2.5 In computing the appropriate drill diameters, it is recommended that the nominal dimensions for D and t listed in Table X1.1 be used for tubes having heavy or very thin wall thicknesses or outside diameter-to-wall thickness ratios that calculate to drill

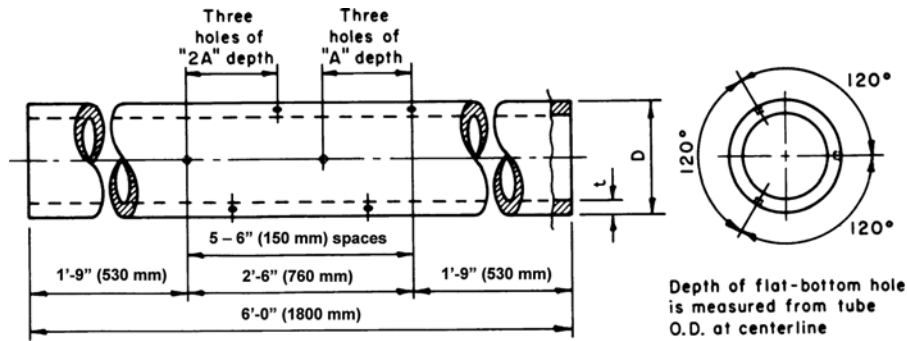

NOTE 1—Tolerance: in. \pm 0.2 in. (mm \pm 5 mm).

NOTE 2—All hole diameters determined by:

$$d = \times 10^{-3}(\text{tube diameter}, t) \text{ in.}$$

$$(d = 76.2 \times 10^{-3} (\text{tube diameter}, D/\text{wall thickness}, t) \text{ mm})$$

NOTE 3—A holes and 2A holes are flat-bottomed and are one third the wall thickness deep and two thirds the wall thickness deep, respectively.

NOTE 4—Nominal dimensions for D and t are recommended from Table X1.1 when calculating appropriate drill diameters for tubes having D/t ratios that result in hole sizes outside the standard drill size range of No. 1 to No. 80.

FIG. X1.1 Primary Reference Standard for Seamless Aluminum-Alloy Tube

TABLE X1.1 Applicable Primary and Secondary Standard Nominal Dimensions and Drill Sizes for Various Ranges- Θ of Tube Sizes

| Inch-Pound, in. | | | | | |
|------------------------|-----------------------------|------------------------------|------------|-------------|-------------|
| Tube Size | Nominal Standard Dimensions | | Drill Size | | |
| Outside Diameter | Dia., $D \pm 10\%$ | Wall Thickness, $t \pm 10\%$ | Primary | Secondary | |
| | | | Dia., d | Dia., d_a | Dia., d_b |
| ≤ 0.0625 to 0.125 | 0.0938 | 0.015 | 0.023 | 0.010 | 0.015 |
| >0.125 to 0.250 | 0.1875 | 0.022 | 0.026 | 0.013 | 0.019 |
| >0.250 to 0.375 | 0.3125 | 0.035 | 0.027 | 0.014 | 0.020 |
| >0.375 to 0.500 | 0.4375 | 0.049 | 0.027 | 0.014 | 0.020 |
| >0.500 to 0.625 | 0.5625 | 0.049 | 0.034 | 0.018 | 0.027 |
| >0.625 to 0.750 | 0.6875 | 0.049 | 0.042 | 0.021 | 0.032 |
| >0.750 to 1.000 | 0.8750 | 0.049 | 0.054 | 0.028 | 0.042 |
| >1.000 to 1.250 | 1.125 | 0.058 | 0.058 | 0.030 | 0.045 |
| >1.250 to 1.500 | 1.375 | 0.058 | 0.071 | 0.036 | 0.055 |
| >1.500 to 1.750 | 1.625 | 0.067 | 0.073 | 0.038 | 0.057 |
| >1.750 to 2.000 | 1.875 | 0.067 | 0.083 | 0.043 | 0.065 |
| >2.000 to 2.500 | 2.250 | 0.076 | 0.089 | 0.046 | 0.069 |
| >2.500 to 3.000 | 2.750 | 0.083 | 0.099 | 0.051 | 0.077 |
| >3.000 to 3.500 | 3.250 | 0.095 | 0.103 | 0.053 | 0.080 |
| >3.500 to 4.000 | 3.750 | 0.095 | 0.118 | 0.061 | 0.092 |

| SI Units, mm | | | | | |
|---------------------|-----------|---------------------|-----------|-------------|-------------|
| Outside Diameter | Dia., D | Wall Thickness, t | Primary | Second | |
| | | | Dia., d | Dia., d_a | Dia., d_b |
| ≤ 1.59 to 3.18 | 2.38 | 0.38 | 0.58 | 0.25 | 0.38 |
| >3.18 to 6.35 | 4.76 | 0.56 | 0.66 | 0.33 | 0.48 |
| >6.35 to 9.53 | 7.94 | 0.89 | 0.69 | 0.36 | 0.51 |
| >9.53 to 12.70 | 11.11 | 1.24 | 0.69 | 0.36 | 0.51 |
| >12.70 to 15.88 | 14.29 | 1.24 | 0.86 | 0.46 | 0.69 |
| >15.88 to 19.05 | 17.46 | 1.24 | 1.07 | 0.53 | 0.81 |
| >19.05 to 25.40 | 22.23 | 1.24 | 1.37 | 0.71 | 1.07 |
| >25.40 to 31.75 | 28.58 | 1.47 | 1.47 | 0.76 | 1.14 |
| >31.75 to 38.10 | 34.93 | 1.47 | 1.80 | 0.91 | 1.40 |
| >38.10 to 44.45 | 41.28 | 1.70 | 1.85 | 0.97 | 1.45 |
| >44.45 to 50.80 | 47.63 | 1.70 | 2.11 | 1.09 | 1.65 |
| >50.80 to 63.50 | 57.15 | 1.93 | 2.26 | 1.17 | 1.75 |
| >63.50 to 76.20 | 69.85 | 2.11 | 2.51 | 1.30 | 1.96 |
| >76.20 to 88.90 | 82.55 | 2.41 | 2.62 | 1.35 | 2.03 |
| >88.90 to 101.60 | 95.25 | 2.41 | 3.00 | 1.55 | 2.34 |

sizes outside the standard drill size range of gage No. 1 to gage No. 80. The dimensions D , t , and d must be expressed in the same units of measurement, that is, millimetres/inches or inches/millimetres when calculating the appropriate drill diameters.

X1.2.6 A standard drill size (drill gage between No. 1 and No. 80 inclusive) nearest the calculated drill diameter, d , may be employed for drilling the hole size required.

X1.3 Identification

X1.3.1 Each primary reference standard shall be clearly marked within the first ~~50 mm [2 in.]~~ 2 in. (50 mm) from the end of the tube adjacent to the 2A holes. The standard shall be marked in a manner that provides rapid identification of the manufacturer, outside diameter, wall thickness, identifying number, alloy, and temper. Permanent identification shall be accomplished by a method not harmful to the tube.

X1.3.2 As a further means of identification, the primary reference standard may be anodized and dyed. This anodizing and coloring provides positive identification and a wear-resistant surface and does not affect the eddy-current response characteristics of the primary reference standard. Caution should be exercised to maintain a uniform anodic coating along the entire length of the tube because boundaries between anodized and unanodized areas may appear as discontinuities during testing.

X1.4 Fabricating Procedure

X1.4.1 The fabricating procedure includes cutting the tube to length, locating and drilling the flat-bottomed holes, deburring and finishing the sawed ends, and identifying the tube as prescribed by X1.3. The use of a jig with suitable interchangeable drill bushings is recommended for drilling the flat-bottomed holes.

X1.4.2 The original outside and inside surfaces of the tube shall be retained without any mechanical refinishing. Care must be taken to avoid dents, abrasions, and other conditions that mar the surface or distort the contour of the tube wall.

X1.4.3 The holes shall be drilled with flat-bottomed drills which are flat to within 2 % of the hole diameter. The drills must meet recognized manufacturers' tolerance for wire-sized drills. The hole depth shall be measured from the outside diameter of the tube to the bottom of the hole along the radial centerline through the hole. Hole depths must be held to within $\pm 0.025 \text{ mm}$ [~~0.001 in.~~] $\pm 0.001 \text{ in.}$ ($\pm 0.025 \text{ mm}$) of the specified depths. A scribe or vibrating pencil should be used to mark the tube surface for drilling in order to avoid local deformation of the tube. The use of a center punch for this purpose is prohibited.

X1.4.4 Tube stock for fabrication of the reference standard shall be free of surface irregularities, bends, and other obvious defects and shall have no bow or out-of-roundness in excess of the maximum specified for tube. (See Fed. Std. No 245.) Tubes shall be free of any eddy-current indication greater than 80 % of the A hole indication prior to fabrication of the standard.

X1.5 Checking

X1.5.1 The finished primary reference standard should be rechecked by recognized gauging procedures to ensure that the outside diameter wall thickness, maximum bow, and maximum out-of-roundness fall within requirements.²

X1.5.2 Each primary reference standard shall be subjected to an eddy-current examination in which the results are recorded on a chart. Annular coils or surface probes may be used for checking reference standards. The instrument shall be adjusted to provide clearly discernible indications of a convenient height for the A holes, but the sensitivity setting shall not be high enough to cause off-scale or saturated indications for the 2A holes.

X1.5.3 To qualify as an acceptable primary reference standard, the response or indication height from any A hole must be within $\pm 20 \%$ of the mean indication height for the three A holes, and the indication height for the 2A holes must be within $\pm 10 \%$ of the mean indication height for the 2A holes.

X1.5.4 The critical portion of the primary reference standard, which extends between points ~~200 mm [8 in.]~~ 200 mm beyond the two outermost holes and includes all of the holes, shall not exhibit eddy-current noise or extraneous indications greater than 80 % of the indication height obtained from the A holes.

X1.6 Report

X1.6.1 A report shall be prepared for each primary reference standard. The report form shall list the manufacturer, outside diameter, wall thickness, serial number, alloy and temper, the drill size, and the depths of the A and 2A holes. The report form shall further indicate that the reference standard complies with requirements specified in X1.5.

X1.6.2 The report shall include a chart record that shows the response from the six flat-bottomed holes in the primary reference standard. The type and model number of the eddy-current instrument, the eddy current sensor size, the speed of examination, and the frequency used in obtaining the chart record also shall be noted.

X1.6.3 It should be recognized that the eddy-current response to the drilled holes may differ somewhat from that originally recorded, depending on the type of instrument used, the eddy current sensor size, the frequency, the degree of filtering, the phase setting, and the speed of examination. These differences in response may be observed even though the instructions given in X1.5 are followed meticulously, but they do not preclude the usefulness of the primary reference standard for its intended application.

X2. PURPOSE, DESCRIPTION, FABRICATION, AND CHECKING OF SECONDARY REFERENCE STANDARDS

X2.1 Purpose

X2.1.1 Secondary reference standards are used to standardize the sensitivity of equipment employed for the electromagnetic examination of aluminum-alloy tubes. They may be used in conjunction with the appropriate primary standard to ensure acceptable limits of sensitivity, reproducibility, and capability for detecting defects of a severity likely to cause leaks or substantial weakening of the tube.