



Designation: E499-95 (Reapproved 2006)

Standard Test Methods for Designation: E499/E499M – 11

Standard Practice for Leaks Using the Mass Spectrometer Leak Detector in the Detector Probe Mode^{1, 2}

This standard is issued under the fixed designation E499/E499M; the number immediately following the designation indicates the year of original adoption or, in the case of revision, the year of last revision. A number in parentheses indicates the year of last reapproval. A superscript epsilon (ϵ) indicates an editorial change since the last revision or reapproval.

This specification has been approved for use by agencies of the Department of Defense.

1. Scope

1.1 These test methods cover procedures for testing and locating the sources of gas leaking at the rate of 4.5×10^{-13} mol/s (1×10^{-8} Std cm³/s)³ or greater. The test may be conducted on any device or component across which a pressure differential of helium or other suitable tracer gas may be created, and on which the effluent side of the leak to be tested is accessible for probing with the mass spectrometer sampling probe.

1.2 Two test methods are described:

1.2.1 *Test Method A*—Direct probing, and

1.2.2 *Test Method B*—Accumulation.

1.3

1.3 *Units*—The values stated in either SI or std-cc/sec units are to be regarded separately as standard. The values stated in each system may not be exact equivalents; therefore, each system shall be used independently of the other. Combining values from the two systems may result in non-conformance with the standard.

1.4 *This standard does not purport to address all of the safety concerns, if any, associated with its use. It is the responsibility of the user of this standard to establish appropriate safety and health practices and determine the applicability of regulatory limitations prior to use.*

2. Referenced Documents

2.1 *ASTM Standards*:⁴

E1316 *Terminology for Nondestructive Examinations*

2.2 *Other Documents*:

SNT-TC-1A Recommended Practice for Personnel Qualification and Certification in Nondestructive Testing⁵

ANSI/ASNT CP-189 ASNT Standard for Qualification and Certification of Nondestructive Testing Personnel⁵

3. Terminology

3.1 *Definitions*—For definitions of terms used in this standard, see Terminology E1316, Section E.

¹ These test methods are under the jurisdiction of ASTM Committee

¹ This practice is under the jurisdiction of ASTM Committee E07 on Nondestructive Testing and is the direct responsibility of Subcommittee E07.08 on Leak Testing Method.

Current edition approved Dec. 1, 2006; July 1, 2006; 2011. Published January 2007; July 2011. Originally approved in 1973. Last previous edition approved in 2000/2006 as E499 - 95(2006). DOI: 10.1520/E0499-95R06-10.1520/E0499_E0499M-11.

² (Atmospheric pressure external, pressure above atmospheric internal). This document covers the Detector Probe Mode described in Guide E432.

³ The gas temperature is referenced to 0°C. To convert to another gas reference temperature, T_{ref} , multiply the leak rate by $(T_{ref} + 273)/273$.

⁴ For referenced ASTM standards, visit the ASTM website, www.astm.org, or contact ASTM Customer Service at service@astm.org. For Annual Book of ASTM Standards volume information, refer to the standard's Document Summary page on the ASTM website.

⁵ Available from American Society for Nondestructive Testing (ASNT), P.O. Box 28518, 1711 Arlington Ln., Columbus, OH 43228-0518, http://www.asnt.org.

*A Summary of Changes section appears at the end of this standard.

4. Summary of Test Methods—Summary of Practice

4.1 Section 1.8 of the Leakage Testing Handbook⁶ will be of value to some users in determining which leak test method to use.

4.2 These test methods require a leak detector with a full-scale readout of at least 4.5×10^{-12} mol/s (1×10^{-6} Pa m³/s)

4.2 The test methods covered in this practice require a leak detector with a full-scale readout of at least 1×10^{-6} Pa m³/s (1×10^{-7} Std cm³/s)³ on the most sensitive range, a maximum 1-min drift of zero and sensitivity of ± 5 % of full scale on this range, and ± 2 % or less on others (see 7.1). The above sensitivities are those obtained by probing an actual standard leak in atmosphere with the detector, or sampling, probe, and *not* the sensitivity of the detector to a standard leak attached directly to the vacuum system.

4.3 *Test Method A, Direct Probing* (see Fig. 1), is the simplest test, and may be used in parts of any size, requiring only that a tracer gas pressure be created across the area to be tested, and the searching of the atmospheric side of the area be with the detector probe. This test method detects leakage and its source or sources. Experience has shown that leak testing down to 4.5×10^{-12} mol/s Pa m³/s (1×10^{-6} Std cm³/s)³ in factory environments will usually be satisfactory if reasonable precautions against releasing gas like the tracer gas in the test area are observed, and the effects of other interferences (Section 6) are considered.

4.4 *Test Method B, Accumulation Testing* (see Fig. 2), provides for the testing of parts up to several cubic metres in volume as in Fig. 2(a) or in portions of larger devices as in Fig. 2(b). This is accomplished by allowing the leakage to accumulate in the chamber for a fixed period, while keeping it well mixed with a fan, and then testing the internal atmosphere for an increase in tracer gas content with the detector probe. The practical sensitivity attainable with this method depends primarily on two things: first, on the volume between the chamber and the object; and second, on the amount of outgassing of tracer gas produced by the object. Thus, a part having considerable exposed rubber, plastic, blind cavities or threads cannot be tested with the sensitivity of a smooth metallic part. The time in which a leak can be detected is directly proportional to the leak rate and inversely proportional to the volume between the chamber and the part. In theory, extremely small leaks can be detected by this test method; however, the time required and the effects of other interferences limit the practical sensitivity of this test method to about 4.5×10^{-12} mol/s Pa m³/s (1×10^{-8} Std cm³/s)³ for small parts.

5. Personnel Qualification

5.1 It is recommended that personnel performing leak testing attend a dedicated training course on the subject and pass a written examination. The training course should be appropriate for NDT level II qualification according to Recommended Practice No. SNT-TC-1A of the American Society for Nondestructive Testing or ANSI/ASNT Standard CP-189.

6. Significance and Use

6.1 Test Method A is frequently used to test large systems and complex piping installations that can be filled with a trace gas. Helium is normally used. The test method is used to locate leaks but cannot be used to quantify except for approximation. Care must be taken to provide sufficient ventilation to prevent increasing the helium background at the test site. Results are limited by the helium background and the percentage of the leaking trace gas captured by the probe.

⁶ Marr, J. William, "Leakage Testing Handbook," prepared for Liquid Propulsion Section, Jet Propulsion Laboratory, National Aeronautics and Space Administration, Pasadena, CA, Contract NAS 7-396, June 1961.

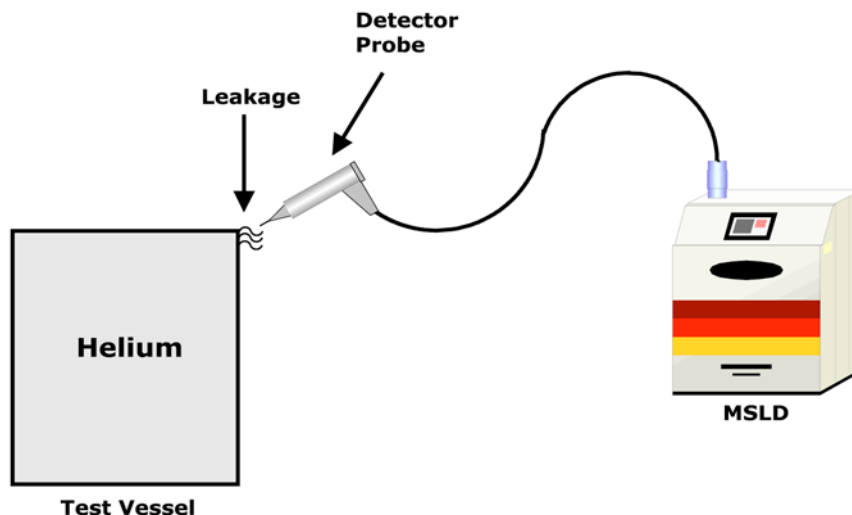
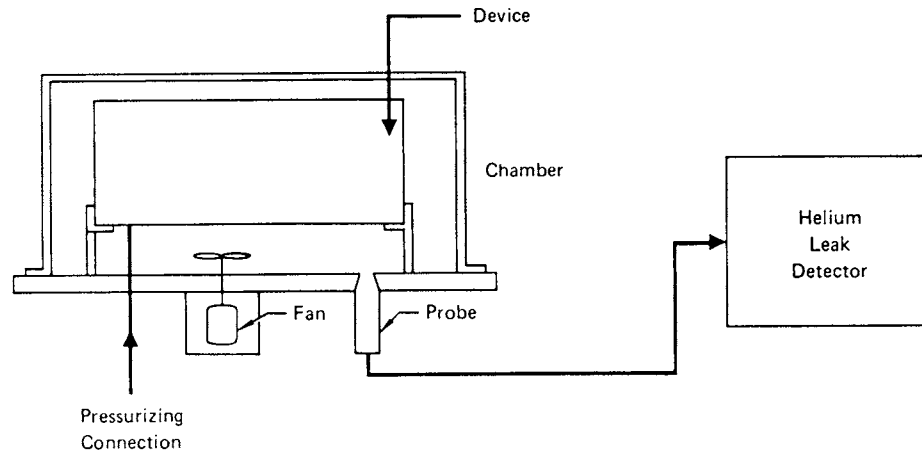
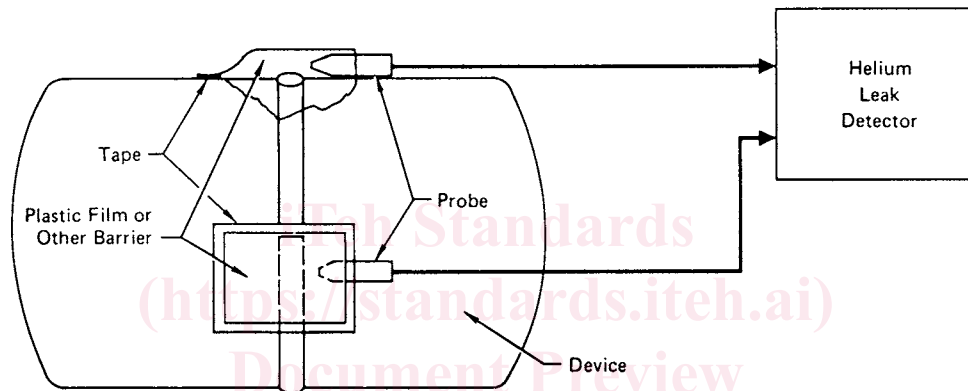

FIG. 1 Method A



a) Accumulation Leak Test, Complete Device in Chamber



b) Accumulation Leak Test, Flexible Shroud over a Small Portion of Device

FIG. 2 Method B

6.2 Test Method B is used to increase the concentration of tracer gas coming through the leak by capturing it within an enclosure until the signal above the helium background can be detected. By introducing a calibrated leak into the same volume for a recorded time interval, leak rates can be measured.

7. Interferences

7.1 *Atmospheric Helium*—The atmosphere contains about five parts per million (ppm) of helium, which is being continuously drawn in by the detector probe. This background must be “zeroed out” before leak testing using helium can proceed. Successful leak testing is contingent on the ability of the detector to discriminate between normal atmospheric helium, which is very constant, and an increase in helium due to a leak. If the normally stable atmospheric helium level is increased by release of helium in the test area, the reference level becomes unstable, and leak testing more difficult.

7.2 *Helium Outgassed from Absorbent Materials*—Helium absorbed in various nonmetallic materials (such as rubber or plastics) may be released during the test. If the rate and magnitude of the amount released approaches the amount released from the leak, the reliability of the test is decreased. The amount of such materials or their exposure to helium must then be reduced to obtain a meaningful test.

7.3 *Pressurizing with Test Gas*—In order to evaluate leakage accurately, the test gas in all parts of the device must contain substantially the same amount of tracer gas. When the device contains air prior to the introduction of test gas, or when an inert gas and a tracer gas are added separately, this may not be true. Devices in which the effective diameter and length are not greatly different (such as tanks) may be tested satisfactorily by simply adding tracer gas. However, when long or restricted systems are to be tested, more uniform tracer distribution will be obtained by first evacuating to less than 100 Pa (a few torr), and then filling with the test gas. The latter must be premixed if not 100 % tracer.

7.4 *Dirt and Liquids*—As the orifice in the detector probe is very small, the parts being tested should be clean and dry to avoid plugging. Reference should be frequently made to a standard leak to ascertain that this has not happened.

8. Apparatus

8.1 *Helium Leak Detector*, equipped with atmospheric detector probe. To perform tests as specified in this standard, the detector