INTERNATIONAL STANDARD



2766

INTERNATIONAL ORGANIZATION FOR STANDARDIZATION • МЕЖДУНАРОДНАЯ ОРГАНИЗАЦИЯ ПО СТАНДАРТИЗАЦИИ • ORGANISATION INTERNATIONALE DE NORMALISATION

**Single lifting hooks with shank — Capacity up to 25 tonnes —
Grades M, P, S (T, V) — Hammer and drop forged hooks**

First edition — 1973-12-01

iTeh STANDARD PREVIEW

(standards.iteh.ai)

ISO 2766:1973

<https://standards.iteh.ai/catalog/standards/sist/cfb807fe-87f8-4474-8a61-76155952b562/iso-2766-1973>

To be withdrawn

UDC 621.86.061

Ref. No. ISO 2766-1973 (E)

Descriptors : hoists, hooks, characteristics, designation, mechanical properties.

FOREWORD

ISO (the International Organization for Standardization) is a worldwide federation of national standards institutes (ISO Member Bodies). The work of developing International Standards is carried out through ISO Technical Committees. Every Member Body interested in a subject for which a Technical Committee has been set up has the right to be represented on that Committee. International organizations, governmental and non-governmental, in liaison with ISO, also take part in the work.

Draft International Standards adopted by the Technical Committees are circulated to the Member Bodies for approval before their acceptance as International Standards by the ISO Council.

International Standard ISO 2766 was drawn up by Technical Committee ISO/TC 111, *Round steel link chains, chain wheels, lifting hooks and accessories*, and circulated to the Member Bodies in June 1972.

It has been approved by the Member Bodies of the following countries :

Austria	Ireland	South Africa, Rep. of
Belgium	Italy	Spain
Bulgaria	Japan	Sweden
France	New Zealand	Thailand
Germany	Portugal	Turkey
India	Romania	United Kingdom

The Member Bodies of the following countries expressed disapproval of the document on technical grounds :

Australia
U.S.A.

Single lifting hooks with shank – Capacity up to 25 tonnes – Grades M, P, S (T, V) – Hammer and drop forged hooks

1 SCOPE

This International Standard, complementing the general characteristics defined by ISO 2141, specifies the shape, numbering, grade, capacity, dimensions and preparation for tests of single lifting hooks with shanks. This International Standard is primarily intended for grades M, P and S hooks but values for grades T and V have been included in the table for the sake of completeness.

2 FIELD OF APPLICATION

This International Standard applies to hooks with a lifting capacity of up to 25 t, made by drop forging¹⁾ or by hammer forging²⁾, which are normally used, after suitable machining of the shank, on lifting appliances.

3 REFERENCES

ISO/R 643, *Micrographic determination of the austenitic grain size of steels.*

ISO/R 1837, *Nomenclature of lifting hooks.*

ISO 2141, *Lifting hooks – General characteristics.*

4 SHAPE

The shape of the hooks is defined by Figure 1, as a function of the data given in the Table; the hooks are characterized by the choice of the optimum load bearing properties of the metal, the form of a flat or concave-sided trapezoid³⁾ being generally chosen for those sections of the body subject to bending stresses. They are designated by the index 1.1 (see ISO/R 1837).

4.1 Boss

The term refers to a shoulder intended to accommodate a safety catch, if this is fitted. The shape and position of the boss is given in Figures 1 and 2, the corresponding sizes being given in the Table. Whether or not a boss is provided depends on the wishes of the purchaser and on the regulations of the countries in which the hook is to be used⁴⁾.

1) Generally in the case of mass-production.

2) Generally in the case of high-capacity units made in limited numbers.

3) Drop-forged hooks are generally hollow-sided, and hand-forged hooks are generally flat-sided.

4) The boss is situated at the beginning of the shank; it may be partly removed by machining.

5 NUMBERING OF HOOKS

Pattern numbers

The hooks are numbered according to their dimensional characteristics which are such that, for a given grade of hook, the maximum lifting capacities are in accordance with the R 10 series of preferred numbers (see Table). The number thus defined is called the "pattern number", to make clear that it does not correspond with the lifting capacity.

6 MATERIALS

6.1 Hooks of grades M and P

The steel is defined as follows :

– It shall be produced by the open hearth process, the electrical process, or an oxygen top blown process.

– In its finished state, as supplied to the manufacturers of the hooks, it shall comply with the following specifications, according to the cast analysis or analysis of the finished hook.

– It shall be fully killed, be capable of being conveniently forged and be capable of being heat treated to obtain the required mechanical properties.

The proportions of sulphur and phosphorus shall be limited as follows :

	Cast analysis	Check analysis
Maximum sulphur	0,045 %	0,050 %
Maximum phosphorus	0,040 %	0,045 %

The steel shall be made in conformity with fine grain practice, to obtain an austenitic grain size of 5 or finer, the test being carried out in accordance with ISO/R 643.

This can be accomplished, for example, by ensuring that it contains sufficient aluminium, or equivalent element, to permit the manufacture of hooks resistant to ageing during use; a minimum value of 0,020 % of metallic aluminium is quoted for guidance.

Within the above limitations, the hook manufacturer is in all cases responsible for the choice of steel so that the finished hook, when suitably heat-treated, will meet the required mechanical properties.

6.2 Steel alloy hooks (grade S and above)

The steel is defined as follows :

- It shall be produced by the open-hearth process, the electrical process or by an oxygen top blown process.
- In its finished state, as supplied to the manufacturers of the hooks, it shall comply with the following specifications, according to the cast analysis or analysis of the finished hook.
- It shall be fully killed, be capable of being conveniently forged, and shall contain alloying elements in sufficient quantities to guarantee the mechanical properties of the hook after appropriate heat treatment.

For example, the steels for grade S hooks shall contain at least one of the following elements :

- | | | |
|------------|---|---------------------|
| Nickel | } | or their equivalent |
| Chromium | | |
| Molybdenum | | |

and the steels for grade T hooks shall contain at least two of the following elements :

- | | | |
|------------|---|---------------------|
| Nickel | } | or their equivalent |
| Chromium | | |
| Molybdenum | | |
| Boron | | |

Neither manganese nor silicon shall be considered in this context as alloying elements.

The proportions of sulphur and phosphorus shall be limited as follows :

	Cast analysis	Check analysis
Maximum sulphur	0,035 %	0,040 %
Maximum phosphorus	0,035 %	0,040 %

The steel shall be made in conformity with fine grain practice, to obtain an austenitic grain size of 5 or finer, the test being carried out in accordance with ISO/R 643.

This can be accomplished, for example, by ensuring that it contains sufficient aluminium, or equivalent element, to permit the manufacture of hooks resistant to ageing during use; a minimum value of 0,020 % of metallic aluminium is quoted for guidance.

Within the above limitations, the hook manufacturer is in all cases responsible for the choice of steel so that the finished hook, when suitably heat-treated, will meet the required mechanical properties.

1) See the International Standards being prepared by ISO/TC 96.

7 GRADE – CAPACITY – MARKING – PROOF LOAD

7.1 Grade of hook

The grade of hooks, designated by the letters M,P,S,T,V, is given in the Table in terms of the values of lifting capacity and proof load.

In relation to these values, the hook shall

- have a fatigue strength enabling it to withstand, without breaking, 400 000 applications of a load corresponding to the lifting capacity given in the Table;
- withstand, without permanent deformation, the application of the proof load. This condition shall be considered to have been fulfilled if, after removal of the proof load, the increase in the opening does not exceed 0,25 %;
- withstand, without shedding the load, the application of a tensile force corresponding to twice the proof load.

7.2 Lifting capacities (C_p)

The lifting capacities are given in the Table for the different grades of hooks. These capacities are valid under the lightest conditions of use. For more intensive use, the working load should be decreased to below these values.¹⁾

7.3 Marking

The marking of hooks shall comprise at least :

- the pattern number N given in the Table;
- an indication of the grade of hook, in accordance with the specifications of the corresponding International Standard;
- the manufacturer's mark and the symbols imposed by national regulations.

7.4 Proof load

The proof loads, in accordance with ISO 2141, are given in the Table.

8 DIMENSIONS

The Table gives the dimensions required for the manufacture of hooks; they are calculated, in millimetres, from the proof load F_e, expressed in kilonewtons, and suitably rounded off so that the figures comply with the preferred numbers series.

For hammer forged hooks, the dimensions given should be complied with as far as possible, especially those dimensions determining the strength of hook.

The length L of the shank is generally specified in relation to the use of the hook. However, it may be stated that, in a large number of cases, the value L = A is acceptable for the dimensions of rough forgings.

9 GEOMETRICAL CONSTRUCTION OF HOOK (see Figures 1 and 2)

This construction is carried out using the dimensions given in the Table. The order of operations is as follows :

1) Plot the vertical axis X-X of the hook and mark on this axis a length $ab = A$;

- with a as the centre, draw a circle of radius $0,5 D$;
- from b , draw a perpendicular to X-X;
- from both sides of b , draw two straight lines cj and hd , both parallel to the axis X-X, and at a distance of $0,5 d_1$ from this axis.

2) Construction of the arc joining the straight line cj and the circle D :

- continue horizontally $cf = ae = 0,5 D$;
- join af ;
- plot the perpendicular bisector of af ; it intersects the continuation of cd at k , which is the centre of the required joining arc of radius R .

3) Construction of the back of the hook :

- on the continuation of ae , continue $el = H_n$;
- following the axis X-X, continue $mn = H_v$;
- draw nl and its perpendicular bisector, which intersects the straight line drawn at 15° to line ca from the point a , at a point p ;
- with p as centre and pl as the radius, draw the curve of the back of the hook.

4) Connecting the back of the hook with the straight line hd :

- proceed following the same method as in 2), which gives the centre q of the connection on the horizontal dc .

5) Construction of point :

- with k as the centre, draw an arc of radius $R + O$ (O being the opening);
- with radius r_1 , join the arc with centre k to circle D ;
- with the same centre as the above connecting arc, draw the arc with radius $r_1 - r_2$;
- draw, at a distance $B - r_2$ from ea , a horizontal line to meet the preceding arc at s ;

- draw the circle with radius r_2 and centre s , join it to the arc with centre p with an arc of radius r_1 .

6) Construction of boss :

a) Drop forged hooks :

- draw a parallel at a distance F from the vertical axis;
- draw a perpendicular to this axis at point t so that $bt = r_3$ (radius of boss), which meets the preceding straight line at u ;
- with u as the centre, draw a circle with radius r_3 ;
- draw, as indicated in Figure 1, two tangents to this circle making an angle between them of 60° .

b) Hammer forged hooks :

- the boss is obtained by pinching the shank while respecting as far as possible the dimensions of the diagram, with the width of the boss not less than $2 r_3$.

7) Construction of cross-sections :

These are specified in Figure 2.

10 MACHINING

The shank shall be machined in accordance with trade practice. In particular, re-entrant angles must be suitably radiused. The manufacturing details of the thread will be defined as soon as possible, but in the meantime the minimum diameter (d_2) at the root of the thread or the machined part shall not be less than the value given in the Table. When the hook is hammer forged or drop forged with a shank shape which enables it to be used directly without machining, the minimum cross-section shall not be less than that corresponding to diameter (d_2) given in the Table.

11 PREPARATION OF HOOKS FOR TESTING UNDER PROOF LOAD AND FOR THE OVERLOAD TEST

When, by agreement between the interested parties, it is decided to carry out the inspection tests defined in clauses 5.2.1 and 5.2.2 of ISO 2141, the shanks must either be machined for use, as specified in section 10, or forged in a suitable form to allow the force to be applied by means of the complete fixing device.

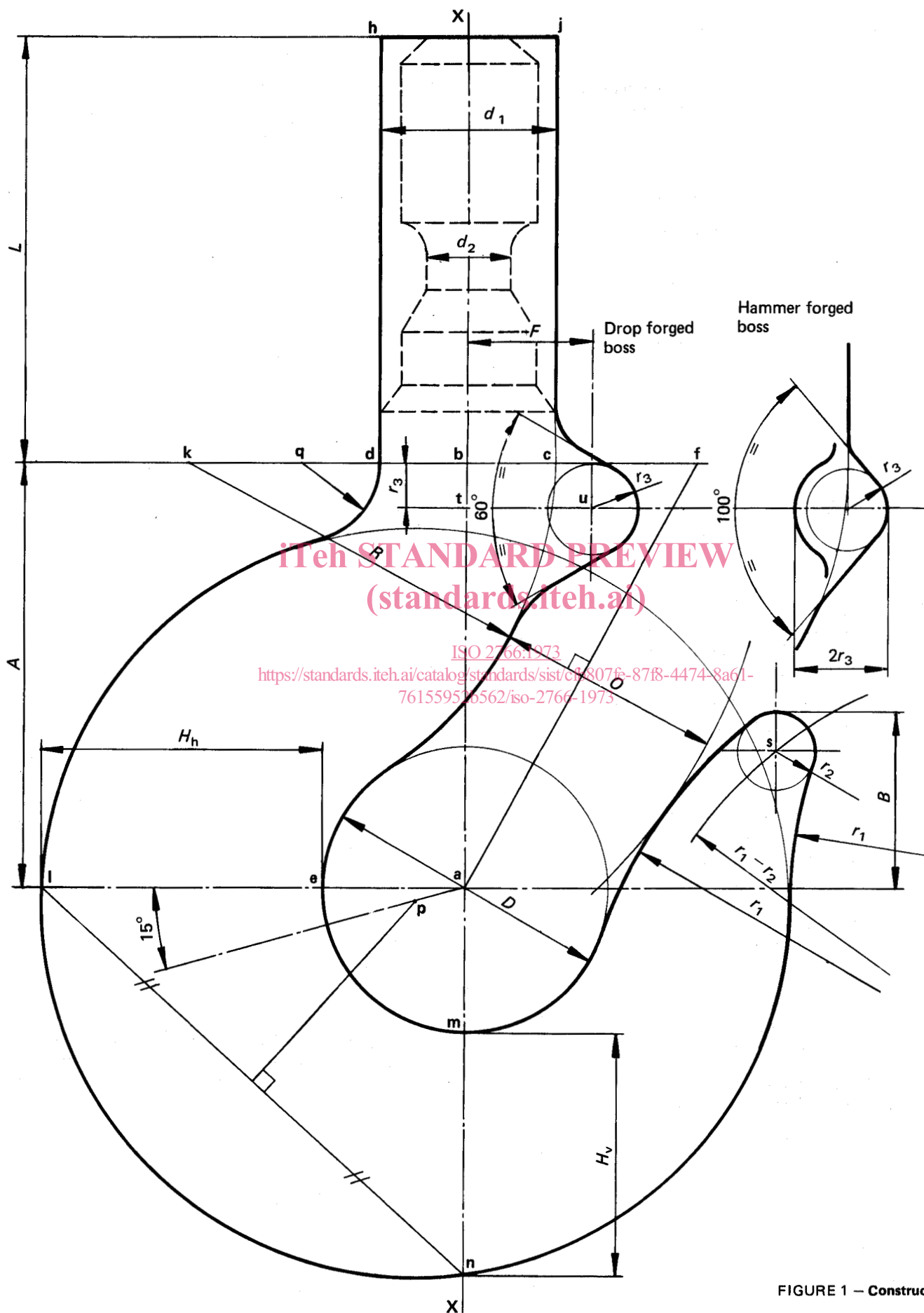
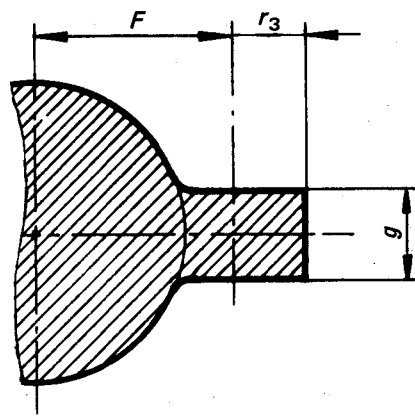
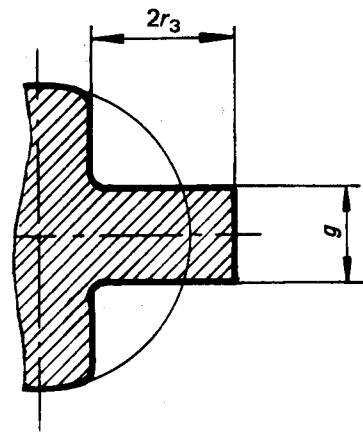

FIGURE 1 — Construction



Drop forged hooks
(Cross-section through tu)



Hammer forged hooks
(Cross-section through tu)

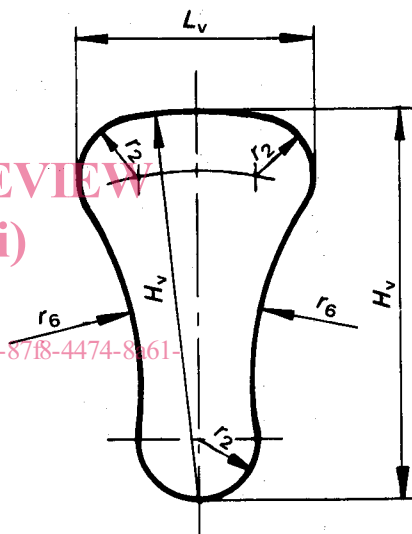
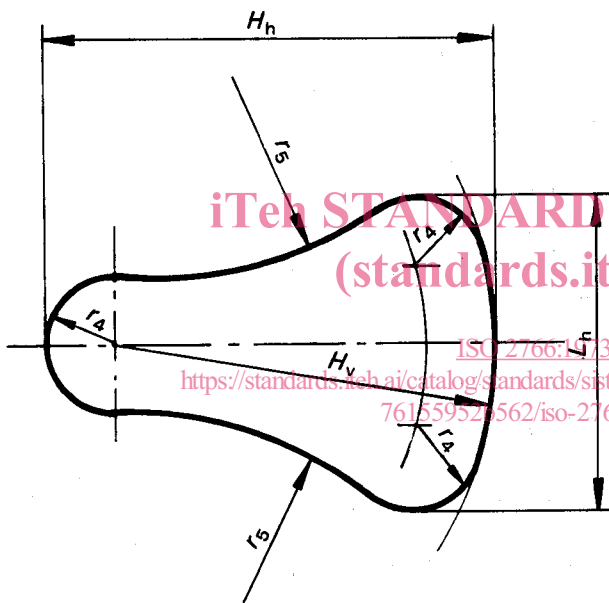

Cross-sections with hollow sides

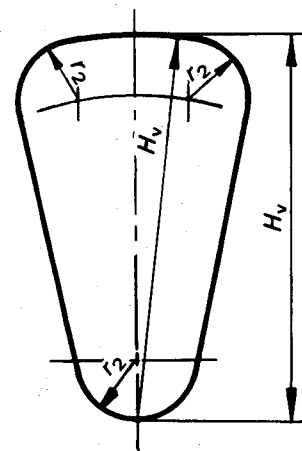
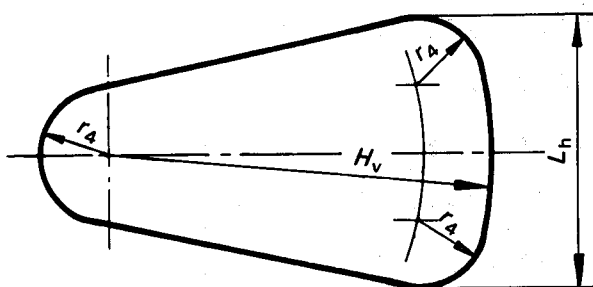

Cross-sections with flat sides

FIGURE 2 – Main cross-sections

TABLE — Mechanical and dimensional characteristics

Pattern No.	Proof load F_{p0} and lifting capacities C_{p0} for grades												r_1	r_2	r_3	r_4	r_6	r_6	θ													
	M		P		S		TT		(V)		L_h	H_h								d_2 min.	F	O	A	B	D	L_v	r_1	r_2	r_3	r_4	r_6	θ
	F_{e0} kN	C_{p0} t	F_{e0} kN	C_{p0} t	F_{e0} kN	C_{p0} t	F_{e0} kN	C_{p0} t	F_{e0} kN	C_{p0} t																						
10	1,6	0,08	2	0,10	2,5	0,125	3,15	4	0,16	4	0,20	22,4	14	33,5	18	70	14	6	15,5	10	12,8	8,5	40	2	3,5	2,3	13,2	10,9	4,5			
11	2	0,10	2,5	0,125	3,15	0,16	4	0,20	0,25	5	0,25	22,4	14	33,5	19	80,6	15	6,5	17	10,9	14	9,3	42,5	2,1	3,7	2,5	14,5	11,8	4,7			
12	2,5	0,125	3,15	0,16	4	0,20	5	0,25	6,3	0,32	25	16	37,5	20	11,2	16	7,1	18,5	11,2	15,5	10	15,5	45	2,3	4,0	2,8	16	12,8	5			
13	3,15	0,16	4	0,20	5	0,25	6,3	0,32	8	0,40	26,5	17	40	21,2	17	7,75	20	12,1	17	17	10,9	10,9	47,6	2,5	4,2	3,0	17,5	14	5,3			
14	4	0,20	5	0,25	6,3	0,32	8	0,40	10	0,50	28	18	42,5	22,4	18	8,5	21,8	13,2	18,5	11,8	11,8	50	2,7	4,5	3,2	19	15,5	5,6				
15	5	0,25	6,3	0,32	8	0,40	10	0,50	12,5	0,63	30	19	45	23,6	19	9,25	23,6	14,5	20	12,8	12,8	53	3	4,7	3,5	20,6	17	6				
16	6,3	0,32	8	0,40	10	0,50	12,5	0,63	16	0,80	31,5	20	47,5	25	14	10	25,7	16	21,8	14	21,8	56	3,3	5,0	3,8	22,4	18,5	6,3				
17	8	0,40	10	0,50	12,5	0,63	16	0,80	20	1,00	33,5	21,2	50	26,5	15	21,2	10,9	28	23,6	15,5	23,6	60	3,5	5,3	4,2	24,3	20	6,7				
18	10	0,50	12,5	0,63	16	0,80	20	1,00	25	1,25	35,5	22,4	53	28	16	22,4	11,8	30,7	19	25,7	17	63	3,9	5,6	4,6	26,5	21,8	7,1				
19	12,5	0,63	16	0,80	20	1,00	25	1,25	31,5	1,60	37,5	23,6	56	30	17	23,6	12,8	33,5	20,6	28	18,5	67	4,3	6,0	5,0	29	23,6	7,5				
20	16	0,80	20	1,00	25	1,25	31,5	1,6	40	2,0	40	25	60	30	18	25	14	36,5	22,4	30,7	20	71	4,6	6,3	5,5	30,7	25,7	8				
21	20	1,00	25	1,25	31,5	1,6	40	2,0	50	2,5	42,5	26,5	63	33,5	19	26,5	15,5	40	24,3	33,5	21,8	75	5	6,7	6,0	33,5	28	8,5				
22	25	1,25	31,5	1,6	40	2,0	50	2,5	63	3,2	45	28	67	36,5	20	28	17	43,7	26,5	36,5	23,6	80	5,5	7,1	6,5	36,5	30,7	9				
23	31,5	1,6	40	2,0	50	2,5	63	3,2	80	4,0	47,5	30	71	37,5	21,2	30	18,5	47,5	29	40	25,7	85	6	7,5	7,1	40	33,5	9,5				
24	40	2,0	50	2,5	63	3,2	80	4,0	100	5,0	50	31,5	75	40	22,4	31,5	20	51,5	31,5	43,7	28	90	6,5	8,0	7,7	43,7	36,5	10				
25	50	2,5	63	3,2	80	4,0	100	5,0	125	6,3	53	33,5	80	42,5	23,6	33,5	21,8	56	34,5	47,5	30,7	95	7,1	8,5	8,5	47,5	40	10,6				
26	63	3,2	80	4,0	100	5,0	125	6,3	160	8,0	60	37,5	90	47,5	26,5	37,5	23,6	60	37,5	50	31,5	100	8	9,5	9	50	42,5	11,8				
27	80	4,0	100	5,0	125	6,3	160	8,0	200	10,0	67	42,5	100	53	30	42,5	25,7	67	42,5	56	36,5	106	9	10,6	10	56	47,5	13,2				
28	100	5,0	125	6,3	160	8,0	200	10,0	250	12,5	75	47,5	112	60	33,5	47,5	28	75	47,5	63	40	118	10	11,8	11,2	63	53	15				
29	125	6,3	160	8,0	200	10,0	250	12,5	315	16	85	53	125	67	37,5	53	30,7	85	53	71	45	132	11,2	13,2	12,5	71	60	17				
30	160	8,0	200	10,0	250	12,5	315	16	400	20	95	60	140	75	42,5	60	33,5	95	60	80	50	150	12,5	15	14	80	67	19				
31	200	10,0	250	12,5	315	16	400	20	500	25	106	67	160	85	47,5	67	37,5	106	67	90	56	170	14	17	16	90	75	21,2				
32	250	12,5	315	16	400	20	500	25	600	30	118	75	180	95	53	75	42,5	118	75	100	63	190	16	19	18	100	85	23,6				
33	315	16	400	20	500	25	600	30	800	40	132	85	200	106	60	85	47,5	132	85	112	71	212	18	21,2	20	112	95	26,5				
34	400	20	500	25	600	30	800	40	1000	50	150	95	224	118	67	95	53	150	95	125	80	236	20	23,6	22,4	125	106	30				
No. 10 to 25	$20\sqrt[4]{F_e}$		$19\sqrt[4]{F_e}$		$18\sqrt[4]{F_e}$		$17\sqrt[4]{F_e}$		$16\sqrt[4]{F_e}$		0,63D		1,5D	0,8D	0,45D	0,63D	$0,056\sqrt[4]{D^3}$	$0,145\sqrt[4]{D^3}$	$0,095\sqrt[4]{D^3}$	$0,121\sqrt[4]{D^3}$	$0,00825\sqrt[4]{D^3}$	1,8D	$0,0185\sqrt[4]{D^3}$	$0,16D$	$0,0218\sqrt[4]{D^3}$	$0,125\sqrt[4]{D^3}$	$0,103\sqrt[4]{D^3}$	0,2D				
	$7,5\sqrt[4]{F_e}$		$6,7\sqrt[4]{F_e}$		$6\sqrt[4]{F_e}$		$5,3\sqrt[4]{F_e}$		$4,75\sqrt[4]{F_e}$		0,63D		1,5D	0,8D	0,45D	0,63D	0,35D*	1,0D	0,63D	0,85D	0,53D	1,6D**	0,132D	0,16D	0,15D	0,85D	0,71D	0,2D				

* Valid only for hooks Nos. 30 to 34. For hooks Nos. 26 to 29 $d_2 = 1,11\sqrt[4]{D^3}$ applies.
 ** Valid only for hooks Nos. 27 to 34. For hooks Nos. 25 to 27 $r_1 = 12,8\sqrt[4]{D}$ applies.