

---

---

## Plastics — Application of spread of flame test to plastic pipes

*Plastiques — Application de l'essai de propagation de flamme aux  
canalisations plastiques*

iTeh STANDARD PREVIEW  
(standards.iteh.ai)

[ISO/PRF 23949](https://standards.iteh.ai/catalog/standards/sist/dd7ca5ef-0887-4862-bf35-66894a163886/iso-prf-23949)

[https://standards.iteh.ai/catalog/standards/sist/dd7ca5ef-0887-4862-bf35-  
66894a163886/iso-prf-23949](https://standards.iteh.ai/catalog/standards/sist/dd7ca5ef-0887-4862-bf35-66894a163886/iso-prf-23949)

# PROOF / ÉPREUVE

---

---



iTeh STANDARD PREVIEW  
(standards.iteh.ai)

ISO/PRF 23949

<https://standards.iteh.ai/catalog/standards/sist/dd7ca5ef-0887-4862-bf35-66894a163886/iso-prf-23949>



**COPYRIGHT PROTECTED DOCUMENT**

© ISO 2023

All rights reserved. Unless otherwise specified, or required in the context of its implementation, no part of this publication may be reproduced or utilized otherwise in any form or by any means, electronic or mechanical, including photocopying, or posting on the internet or an intranet, without prior written permission. Permission can be requested from either ISO at the address below or ISO's member body in the country of the requester.

ISO copyright office  
CP 401 • Ch. de Blandonnet 8  
CH-1214 Vernier, Geneva  
Phone: +41 22 749 01 11  
Email: [copyright@iso.org](mailto:copyright@iso.org)  
Website: [www.iso.org](http://www.iso.org)

Published in Switzerland

# Contents

	Page
Foreword.....	iv
Introduction.....	v
<b>1 Scope.....</b>	<b>1</b>
<b>2 Normative references.....</b>	<b>1</b>
<b>3 Terms and definitions.....</b>	<b>1</b>
<b>4 Principle.....</b>	<b>1</b>
<b>5 Test apparatus.....</b>	<b>1</b>
<b>6 Test specimen.....</b>	<b>2</b>
6.1 General.....	2
6.2 Number of test specimens.....	2
6.3 Thickness of the test specimen.....	2
6.4 Rigid pipes.....	2
6.5 Flexible pipes.....	4
<b>7 Conditioning of specimens.....</b>	<b>4</b>
<b>8 Test procedures.....</b>	<b>4</b>
8.1 General.....	4
8.2 Additional test procedures for pipes.....	4
<b>9 Calculation of the test results.....</b>	<b>5</b>
<b>10 Precision of the test.....</b>	<b>5</b>
<b>11 Test report.....</b>	<b>5</b>
<b>Annex A (informative) Example of the test results on plastic pipes.....</b>	<b>7</b>
<b>Bibliography.....</b>	<b>10</b>

## Foreword

ISO (the International Organization for Standardization) is a worldwide federation of national standards bodies (ISO member bodies). The work of preparing International Standards is normally carried out through ISO technical committees. Each member body interested in a subject for which a technical committee has been established has the right to be represented on that committee. International organizations, governmental and non-governmental, in liaison with ISO, also take part in the work. ISO collaborates closely with the International Electrotechnical Commission (IEC) on all matters of electrotechnical standardization.

The procedures used to develop this document and those intended for its further maintenance are described in the ISO/IEC Directives, Part 1. In particular, the different approval criteria needed for the different types of ISO documents should be noted. This document was drafted in accordance with the editorial rules of the ISO/IEC Directives, Part 2 (see [www.iso.org/directives](http://www.iso.org/directives)).

Attention is drawn to the possibility that some of the elements of this document may be the subject of patent rights. ISO shall not be held responsible for identifying any or all such patent rights. Details of any patent rights identified during the development of the document will be in the Introduction and/or on the ISO list of patent declarations received (see [www.iso.org/patents](http://www.iso.org/patents)).

Any trade name used in this document is information given for the convenience of users and does not constitute an endorsement.

For an explanation of the voluntary nature of standards, the meaning of ISO specific terms and expressions related to conformity assessment, as well as information about ISO's adherence to the World Trade Organization (WTO) principles in the Technical Barriers to Trade (TBT), see [www.iso.org/iso/foreword.html](http://www.iso.org/iso/foreword.html).

This document was prepared by Technical Committee ISO/TC 61 *Plastics*, Subcommittee SC 4, *Burning behaviour*.

ISO/PRF 23949

Any feedback or questions on this document should be directed to the user's national standards body. A complete listing of these bodies can be found at [www.iso.org/members.html](http://www.iso.org/members.html).

## Introduction

Plastic pipes and fiberglass reinforced plastic (FRP) pipes exhibit corrosion resistance against water including sea water and liquid chemicals. These pipes have been used on ships in various applications, such as piping supplying fresh water, sanitary and drain piping, sea-water piping and liquid cargo piping.

The International Maritime Organization (IMO) adopted guidelines on use of plastic pipes (see Reference [1]). These guidelines contain requirements on the fire performance of plastic pipes and of FRP pipes to be used on-board ships. These guidelines also contain brief explanation of test procedures applicable to flame spread for plastics pipes and FRP pipes. However, the details provided regarding these fire tests are very short and are insufficient to conduct these tests in a uniform manner.

This document was developed based on the IMO Guidelines, ISO 5658-2:2006, Annex E and the NATO Reaction-to-fire tests for materials surface spread of flame (see AFAP – 4 Edition 3[2]). It provides detailed descriptions of the test methods for assessing the flame spread of plastic pipes and FRP pipes.

This document is applicable, on a voluntary basis, to plastic pipes and to FRP pipes for use in ships, air crafts, vehicles, building and land-based structures.

iTeh STANDARD PREVIEW  
(standards.iteh.ai)

ISO/PRF 23949

<https://standards.iteh.ai/catalog/standards/sist/dd7ca5ef-0887-4862-bf35-66894a163886/iso-prf-23949>



# Plastics — Application of spread of flame test to plastic pipes

## 1 Scope

This document specifies test methods for assessing the flame spread of plastic pipes including fiberglass reinforced plastic (FRP) pipes. This document is applicable to plastic pipes including FRP pipes for use in ships, air crafts and vehicles.

## 2 Normative references

The following documents are referred to in the text in such a way that some or all of their content constitutes requirements of this document. For dated references, only the edition cited applies. For undated references, the latest edition of the referenced document (including any amendments) applies.

ISO 5658-2:2006, *Reaction to fire tests — Spread of flame — Part 2: Lateral spread on building and transport products in vertical configuration*

ISO 13943, *Fire safety — Vocabulary*

## 3 Terms and definitions

For the purposes of this document, the terms and definitions given in ISO 5658-2, ISO 13943 apply.

ISO and IEC maintain terminological databases for use in standardization at the following addresses:

- ISO Online browsing platform: available at <https://www.iso.org/obp>
- IEC Electropedia: available at <https://www.electropedia.org/>

## 4 Principle

The test procedure in this document uses the test method given in ISO 5658-2 to evaluate the surface spread of flame characteristics of test specimens. Additional test protocols and procedures for testing plastic pipes are also specified in this document.

The test specimen is constructed in such a way that plastic pipes are cut to a length of 800 mm. The length of cut pipes are further cut laterally. The cut pipe sections are placed side by side on a non-combustible backing board, with dimensions of 155 mm wide and 800 mm long. The test specimens are secured by means of narrow metal wires. The test specimen is exposed to a graded radiant heat flux field, as specified in ISO 5658-2.

Data on critical heat flux at extinguishment and average heat for sustained burning are derived from observations of time to ignition, lateral spread and extinguishment of flame along the surface of the test specimen which is exposed such that the surface is vertical and the longer edge in horizontal.

## 5 Test apparatus

The test apparatus described in ISO 5658-2 shall be used. The test apparatus shall be adjusted, calibrated and controlled in accordance with ISO 5658-2.

## 6 Test specimen

### 6.1 General

Tests shall be conducted for each pipe material.

Test results are affected by the thickness of the pipe wall and the curvature (diameter) of the pipe.

### 6.2 Number of test specimens

Unless otherwise agreed among the parties concerned, at least six test specimens shall be supplied for testing. The material, mass and dimensions of the test specimen shall be recorded in the test report.

### 6.3 Thickness of the test specimen

Pipes of a thickness of 40 mm or less shall be tested at their full thickness. For pipes of a wall thickness greater than 40 mm, the unexposed face shall be cut away so as to reduce the test specimen thickness to 40 mm. The original thickness and the reduction in thickness shall be recorded in the test report.

### 6.4 Rigid pipes

6.4.1 The samples of plastic pipes shall be cut to length of  $(800^{+0}_{-5})$  mm.

6.4.2 If the inner diameter of the pipe is greater than 10 mm, the pipes shall be further cut laterally in a such way that the height under the curvature of the sections shall be equal to or less than 5 mm as shown in [Figure 1](#).

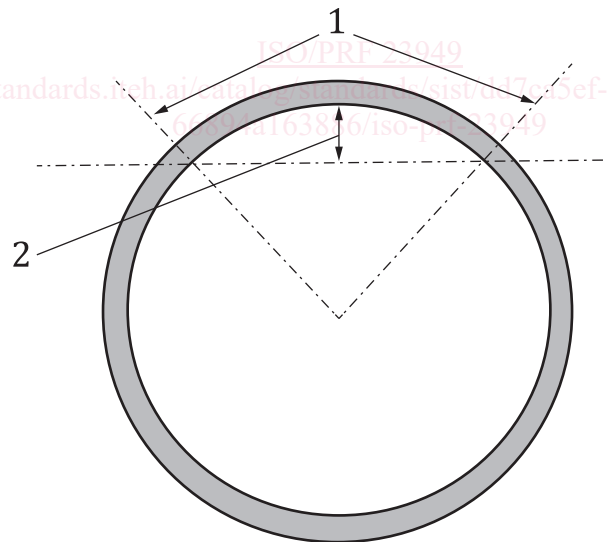

#### Key

- 1 lines of cuttings
- 2 height equal to or less than 5 mm

**Figure 1 — Method of cutting of pipe sample**

6.4.3 If the inner diameter of the pipe is greater than 5 mm but less than or equal to 10 mm, the cut pipe shall be further cut laterally into two equal parts.



**6.4.4** If the inner diameter of the pipe is equal to or less than 5 mm, the pipes cut to a length of 800 mm shall be used for assembling the pipes into the test specimen.

**6.4.5** If the inner diameter of the pipe is equal to or less than 40 mm, and it has been agreed among the parties concerned, it shall be acceptable to test the pipe at its full section regardless of the requirements shown in 6.4.2 to 6.4.4.

**6.4.6** The pipe sections cut according to 6.4.1 to 6.4.5, shall be placed on a non-combustible backing board having a nominal density of  $(900 \pm 100)$  kg/m<sup>3</sup>, a width of  $155^{+0}_{-5}$  mm, a length of  $800^{+0}_{-5}$  mm, a thickness of  $20 \pm 1$  mm. The pipe test specimens shall be secured by means of narrow metal wires (preferably stainless steel wire having approximately 0,5 mm in diameter) tightened by twisting at the back surface of the backing board.

**6.4.7** The assembled test specimen shall exhibit no gaps between individual pipe sections. The distance between the securing (fixing) wires shall be such that they ensure that the pipe sections shall remain in place when the surface of test specimen is exposed vertically and the long edge of the test specimen is horizontal. The number of pipe sections to be assembled together to form each test specimen shall be such that the total width of the lined pipe sections is as much as possible to 155 mm. The typical specimen assembly is shown in Figure 2.

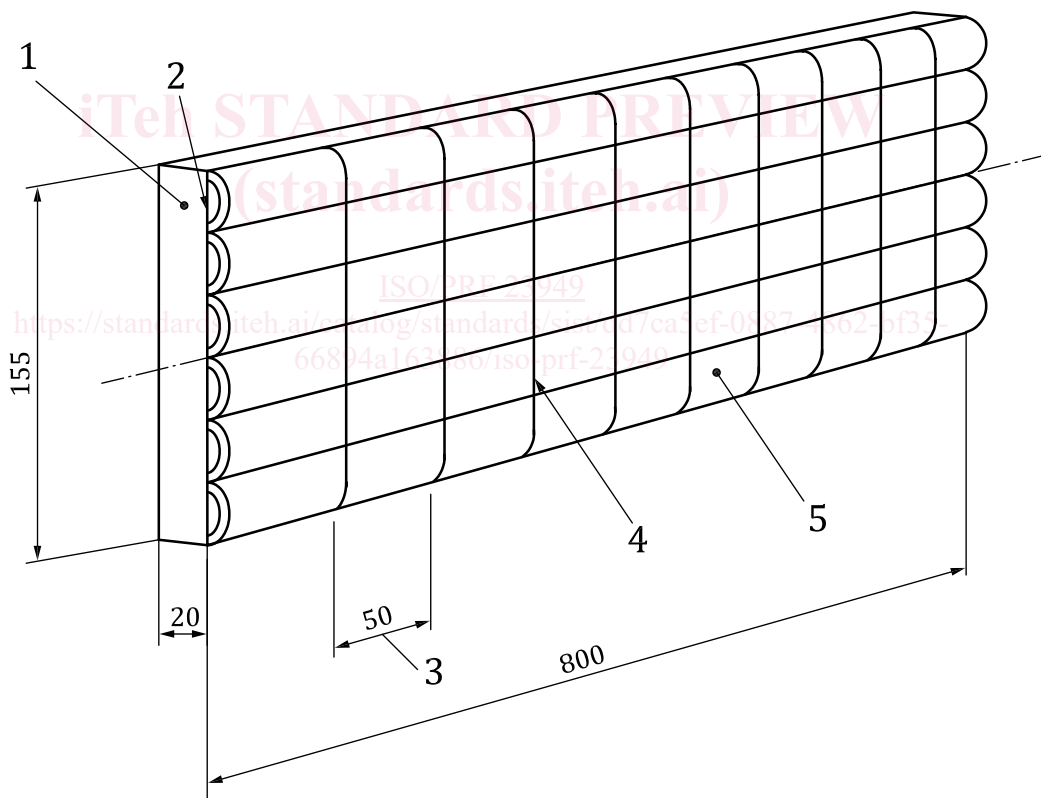

**Key**

- 1 calcium silicate board (substrate)
- 2 edge of the pipe specimen sealed by mineral wool.
- 3 interval of the wire
- 4 wire
- 5 pipe test specimen

**Figure 2 — Typical mounting and fixing of a test specimen constructed from pipe sections**

**6.4.8** In case the plastic pipe undergoes deformations or softening when exposed to the heat resulting from the test, the pipe sections shall be affixed to the non-combustible backing board by using thin wire mesh. An example of a fixing system using wire mesh is shown in [Figure 3](#).

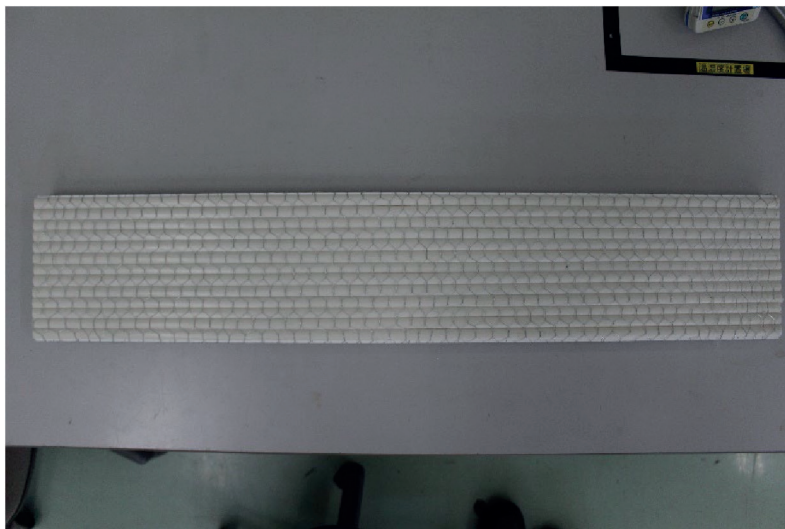

**Figure 3 — Example of test specimen where a wire mesh is used for fixing pipe sections**

**6.4.9** The space between the concave unexposed surface of the test sections and the surface of the non-combustible backing board shall be left void.

## **6.5 Flexible pipes**

Flexible pipes shall be performed to be tested, if the pipe is able to be fixed in accordance with [6.4](#) and is able to be kept in a stable condition as secured to the test specimen backing board. In case a flexible pipe specimen cannot be secured firmly under the fixing wires (see [Figure 1](#)), it is acceptable to use small pins or nail for fixing the pipes to the backing board.

## **7 Conditioning of specimens**

The test specimens shall be conditioned to constant mass at a temperature of  $(23 \pm 2)$  °C, and a relative humidity of  $(50 \pm 5)$  % and maintained in this condition until required for testing. Constant mass is considered to be attained when two successive weighing operations, carried out at an interval of 24 h, do not differ by more than 0,1 % of the mass of the specimen, or 0,1 g, whichever is the greater.

## **8 Test procedures**

### **8.1 General**

The test shall be conducted in accordance with ISO 5658-2.

### **8.2 Additional test procedures for pipes**

In the cases of plastic pipes which have a thick wall (e.g. a thickness of over 5 mm), it is feasible that the specimen will develop large amount of fumes and gases. In such cases, care shall be taken to effectively exhaust the fumes and gases during the tests.