

ISO/FDIS 12311:2023(E)

ISO/TC 94/SC 6/~~WG 2~~

Secretariat: BSI

Date: 2023-~~07-27~~~~xx~~

Personal protective equipment — Test methods for sunglasses and related eyewear

Équipement de protection individuelle — Méthodes d'essai pour lunettes de soleil et articles de lunetterie associés

Style Definition: Heading 1: Indent: Left: 0 pt, First line: 0 pt, Tab stops: Not at 21.6 pt

Style Definition: Heading 2: Font: Bold, Tab stops: Not at 18 pt

Style Definition: Heading 3: Font: Bold

Style Definition: Heading 4: Font: Bold

Style Definition: Heading 5: Font: Bold

Style Definition: Heading 6: Font: Bold

Style Definition: ANNEX

Style Definition: TOC Heading

Style Definition: AMEND Terms Heading: Font: Bold

Style Definition: AMEND Heading 1 Unnumbered: Font: Bold

iTeh STANDARD PREVIEW
(standards.iteh.ai)

[ISO/FDIS 12311](https://standards.iteh.ai/catalog/standards/sist/63592122-f820-45dc-a7fa-eed92af6278d/iso-fdis-12311)

<https://standards.iteh.ai/catalog/standards/sist/63592122-f820-45dc-a7fa-eed92af6278d/iso-fdis-12311>

© ISO 2023

All rights reserved. Unless otherwise specified, or required in the context of its implementation, no part of this publication may be reproduced or utilized otherwise in any form or by any means, electronic or mechanical, including photocopying, or posting on the internet or an intranet, without prior written permission. Permission can be requested from either ISO at the address below or ISO's member body in the country of the requester.

ISO copyright office

CP 401 • Ch. de Blandonnet 8

CH-1214 Vernier, Geneva

Phone: +41 22 749 01 11

Email: copyright@iso.org

Website: www.iso.org

Published in Switzerland

Formatted: Pattern: Clear

Formatted: Pattern: Clear

iTeh STANDARD PREVIEW
(standards.iteh.ai)

ISO/FDIS 12311

<https://standards.iteh.ai/catalog/standards/sist/63592122-f820-45dc-a7fa-eed92af6278d/iso-fdis-12311>

Contents

Foreword.....	4
1 — Scope.....	5
2 — Normative references	5
3 — Terms and definitions.....	5
4 — Prerequisites.....	5
5 — General test requirements	6
6 — Test methods for mechanical properties.....	6
6.1 — Test method for frame deformation and filter retention.....	6
6.1.1 Principle.....	6
6.1.2 Apparatus.....	6
6.1.3 Procedure.....	7
6.1.4 Verification and test report.....	8
6.1.5 Uncertainty of measurement.....	9
6.2 — Test method for increased endurance of sunglasses.....	9
6.2.1 Principle.....	9
6.2.2 Apparatus.....	9
6.2.3 Procedure.....	9
6.2.4 Verification and test report.....	14
6.2.5 Uncertainty of measurement.....	14
6.3 — Test for resistance to perspiration of the sunglass frame.....	14
6.3.1 Principle.....	14
6.3.2 Apparatus and reagents.....	14
6.3.3 Procedure.....	15
6.3.4 Verification and test report.....	16
Annex A (normative) Application of uncertainty of measurement.....	17
Foreword.....	iv
1 — Scope.....	1
2 — Normative references	1
3 — Terms and definitions.....	1

ISO/FDIS 12311:2023(E)

4	Prerequisites.....	2
5	General test requirements.....	2
6	Test methods for mechanical properties.....	2
6.1	Test method for frame deformation and filter retention	2
6.1.1	Principle.....	2
6.1.2	Apparatus.....	2
6.1.3	Procedure.....	3
6.1.4	Report.....	4
6.1.5	Uncertainty of measurement.....	5
6.2	Test method for increased endurance of sunglasses	5
6.2.1	Principle.....	5
6.2.2	Apparatus.....	5
6.2.3	Procedure.....	6
6.2.4	Report.....	9
6.2.5	Uncertainty of measurement.....	9
6.3	Test for resistance to perspiration of the sunglass frame	9
6.3.1	Principle	9
6.3.2	Apparatus and reagents	9
6.3.3	Procedure.....	10
6.3.4	Report.....	11
	Annex A (normative) Application of uncertainty of measurement.....	12
	Bibliography.....	14

ITIH STANDARD PREVIEW
(standards.iteh.ai)

[ISO/FDIS 12311](https://standards.iteh.ai/catalog/standards/sist/63592122-f820-45dc-a7fa-eed92af6278d/iso-fdis-12311)

<https://standards.iteh.ai/catalog/standards/sist/63592122-f820-45dc-a7fa-eed92af6278d/iso-fdis-12311>

Foreword

ISO (the International Organization for Standardization) is a worldwide federation of national standards bodies (ISO member bodies). The work of preparing International Standards is normally carried out through ISO technical committees. Each member body interested in a subject for which a technical committee has been established has the right to be represented on that committee. International organizations, governmental and non-governmental, in liaison with ISO, also take part in the work. ISO collaborates closely with the International Electrotechnical Commission (IEC) on all matters of electrotechnical standardization.

Formatted: Adjust space between Latin and Asian text, Adjust space between Asian text and numbers

The procedures used to develop this document and those intended for its further maintenance are described in the ISO/IEC Directives, Part 1. In particular, the different approval criteria needed for the different types of ISO documents should be noted. This document was drafted in accordance with the editorial rules of the ISO/IEC Directives, Part 2 (see www.iso.org/directives).

~~Attention is drawn to the possibility that some of the elements of this document may be involved in the subject of a patent(s). ISO takes no position concerning the evidence, validity or applicability of any claimed patent rights in respect thereof. As of the date of publication of this document, ISO had not received notice of (a) patent(s) which may be required to implement this document. However, implementers are cautioned that this may not represent the latest information, which may be obtained from the patent database available at www.iso.org/patents. ISO shall not be held responsible for identifying any or all such patent rights. Details of any patent rights identified during the development of the document will be in the Introduction and/or on the ISO list of patent declarations received (see www.iso.org/patents).~~

Any trade name used in this document is information given for the convenience of users and does not constitute an endorsement.

For an explanation of the voluntary nature of standards, the meaning of ISO specific terms and expressions related to conformity assessment, as well as information about ISO's adherence to the World Trade Organization (WTO) principles in the Technical Barriers to Trade (TBT), see www.iso.org/iso/foreword.html.

Formatted: English (United States)

This document was prepared by Technical Committee ISO/TC 94 *Personal safety — Personal protective equipment*, Subcommittee SC 6 *Eye and face protection*, in collaboration with the European Committee for Standardization (CEN) Technical Committee CEN/TC 85, *Eye-protective equipment*, in accordance with the Agreement on technical cooperation between ISO and CEN (Vienna Agreement).

This second edition cancels and replaces the first edition (ISO 12311:2013), which has been technically revised.

Formatted: Pattern: Clear

Formatted: Pattern: Clear

Formatted: Pattern: Clear

The main changes are as follows:

- with the publication of the four parts of ISO 18526 in 2020, which provides test methods and specifications for head forms for the compliance testing of eye protectors, it was deemed unnecessary to reproduce details of these test methods in ISO 12311. They have therefore been removed. Test methods that have been retained in this document are those developed originally for testing of spectacle frames. Corresponding Annexes that supplemented the now deleted test methods have also been removed.

Formatted: Pattern: Clear

Formatted: Pattern: Clear

Formatted: Pattern: Clear

Formatted: Pattern: Clear

ISO/FDIS 12311:2023(E)

Any feedback or questions on this document should be directed to the user's national standards body. A complete listing of these bodies can be found at www.iso.org/members.html.

iTeh STANDARD PREVIEW
(standards.iteh.ai)

ISO/FDIS 12311

<https://standards.iteh.ai/catalog/standards/sist/63592122-f820-45dc-a7fa-eed92af6278d/iso-fdis-12311>

Personal protective equipment — Test methods for sunglasses and related eyewear

1 Scope

This document specifies reference's test methods for determining the properties of sunglasses given in [ISO 12312](#) (all parts). It is applicable to all sunglasses and related eyewear.

Other test methods can be used if proven to be equivalent.

Formatted: Pattern: Clear

Formatted: Pattern: Clear

Formatted: Pattern: Clear

2 Normative references

The following documents are referred to in the text in such a way that some or all of their content constitutes requirements of this document. For dated references, only the edition cited applies. For undated references, the latest edition of the referenced document (including any amendments) applies.

~~<std>ISO 1042, Laboratory glassware — One mark volumetric flasks</std>~~

~~<std>ISO 3696, Water for analytical laboratory use — Specification and test methods</std>~~

~~<std>ISO 4007, Personal protective equipment — Eye and face protection — Vocabulary</std>~~

~~<std>ISO 8624, Ophthalmic optics — Spectacle frames — Measuring system and vocabulary</std>~~

~~<std>ISO/IEC Guide 98-3, Uncertainty of measurement — Part 3: Guide to the expression of uncertainty in measurement (GUM:1995)</std>~~

[ISO 1042, Laboratory glassware — One-mark volumetric flasks](#)

[ISO 3696, Water for analytical laboratory use — Specification and test methods](#)

[ISO 4007, Personal protective equipment — Eye and face protection — Vocabulary](#)

[ISO 8624, Ophthalmic optics — Spectacle frames — Measuring system and vocabulary](#)

[ISO/IEC Guide 98-3, Uncertainty of measurement — Part 3: Guide to the expression of uncertainty in measurement \(GUM:1995\)](#)

3 Terms and definitions

For the purposes of this document, the terms and definitions given in [ISO 4007](#) and [ISO 8624](#) apply.

ISO and IEC maintain terminological databases for use in standardization at the following addresses:

- ISO Online browsing platform: available at <https://www.iso.org/obp>
- IEC Electropedia: available at <https://www.electropedia.org/>

Formatted: Pattern: Clear

Formatted: Pattern: Clear

4 Prerequisites

The following parameters shall be specified prior to testing [see ISO 12312 (all parts)]:

- the number of test samples;
- test sample preparation;
- any conditioning prior to testing;
- characteristics to be assessed subjectively (if appropriate);
- pass/fail criteria.

Formatted: Pattern: Clear

Formatted: Pattern: Clear

Formatted: Pattern: Clear

5 General test requirements

Unless otherwise specified, the values stated in this document are expressed as nominal values. Except for temperature limits, values which are not stated as maxima or minima shall be subject to a tolerance of $\pm 5\%$. Unless otherwise specified, the ambient temperature for testing shall be between $16\text{ }^{\circ}\text{C}$ and $32\text{ }^{\circ}\text{C}$. Where other temperature limits are specified, they shall be subject to an accuracy of $\pm 2\text{ }^{\circ}\text{C}$. Relative humidity shall be maintained at $(50 \pm 20)\%$.

~~Details of the material of reference test headforms to be used shall be as given in Annex B.~~

Unless otherwise specified, the filters shall be tested at the reference points as defined in ISO 4007.

Formatted: Pattern: Clear

Formatted: Pattern: Clear

6 Test methods for mechanical properties

6.1 Test method for frame deformation and filter retention

6.1.1 Principle

This procedure tests the ability of the complete sunglass to resist deformation and to retain the filters.

6.1.2 Apparatus

6.1.2.1 Overall scheme, the test apparatus consists of an annular clamp, a downward-operating pressure peg and a measuring device. See Figure 1.

Formatted: Pattern: Clear

6.1.2.2 Annular clamp, (see Figure 1, key item 2) shall be capable of holding the test sample without twist or slip and have a diameter of (25 ± 2) mm, with two contact surfaces, E_1 and E_2 , made of a firm elastic material (e.g. polyamide). The clamping surfaces shall be capable of being separated at least 10 mm on either side of a horizontal line going through the apparatus. To accommodate frames with a significant face form angle, the annular clamp shall also be capable of rotating about a horizontal axis so that the axis of the pressure peg (6.1.2.3) remains vertical and perpendicular to the plane of the unclamped lens at its boxed centre.

Formatted: Pattern: Clear

Formatted: Pattern: Clear

6.1.2.3 Pressure peg, (see Figure 1, key item 5) which operates vertically downwards shall have a diameter of (10 ± 1) mm with a nominally hemispherical contact surface. The pressure peg shall be capable of travelling from at least 10 mm above the horizontal line to not more than 8 mm below. The horizontal distance between the annular clamp and pressure peg is adjustable. The pressure peg slides in a guiding sleeve (See Figure 1, key item 4) that maintains its vertical orientation and lateral position.

Formatted: Pattern: Clear

Formatted: Pattern: Clear

6.1.2.4 **Measuring device**, to measure the linear displacement of the pressure peg, with an uncertainty no greater than $\pm 0,1$ mm.

Linear dimensions in millimetres

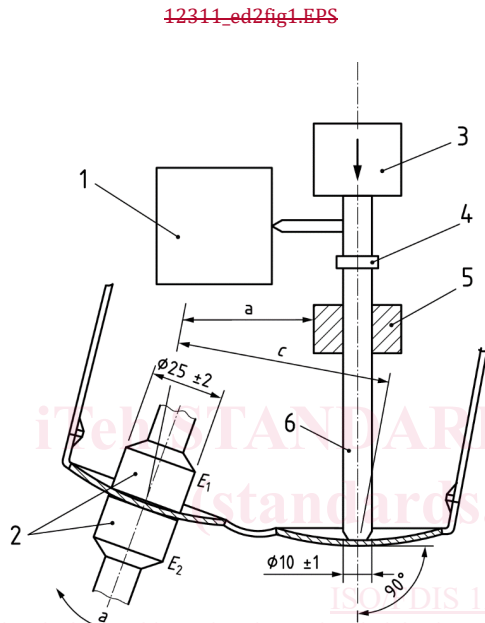

Key

- 1 measuring device
- 2 annular clamp
- 3 direction and point of application of force (maximum 5 N)
- 4 displacement limiting device (optional)
- 5 guiding sleeve
- 6 pressure peg
- c boxed centre distance (adjustable)
- E_1, E_2 contact surfaces
- a Adjustable.

Figure 1 — Illustration of frame deformation and filter retention test

6.1.3 Procedure

6.1.3.1 Mount the test sample on the device with the sides of the sample extended and with the front of the sample facing downwards. Clamp the sample within 2 mm of the boxed centre of one filter (see Figure 1).

Formatted: Pattern: Clear

ISO/FDIS 12311:2023(E)

If the sides are in the way of mounting the frame, e.g. jointless sides, then it is permissible to remove them, but if so, the endurance test (6.2) shall be performed first. Since the endurance test may be a more severe test of the frame's mechanical strength, the preferred option is to subject the sample to the bridge deformation and lens retention test before the endurance test.

Formatted: Pattern: Clear

Lower the pressure peg so that it rests on the back surface of the unclamped filter within 2 mm of its boxed centre, ensuring that there is no movement of the filter. Record the reading on the linear measuring device as the starting position.

Move the pressure peg slowly and smoothly downwards, increasing the force until the first of the following criteria is reached:

- a) a maximum force of 5 N;
- b) a displacement of the pressure peg from the starting position equal to (10 ± 1) % of the distance between boxed centres, c . An optional displacement limiting ring (key 4 in see Figure 1, key item 4) can be used to limit the movement of the pressure peg.

Formatted: Pattern: Clear

6.1.3.2 If the maximum force of 5 N is insufficient to displace the pressure peg over the distance specified in 6.1.3.1 b), record the displacement and then continue the test.

Formatted: Pattern: Clear

Maintain the force or displacement, whichever was achieved first, for 5 s, then remove the force and lift the pressure peg away from the filter. After a relaxation period of 20 s, slowly and smoothly lower the pressure peg until it just rests on the filter again. Record this as the final position of the pressure peg.

6.1.3.3 Calculate the distance between the starting and final positions of the pressure peg, x , and calculate the percentage deformation using formula Formula 1.

Formatted: Pattern: Clear

$$f = \frac{x}{c} \times 100 \quad f = \frac{x}{c} \times 100 \quad (1)$$

Formatted: Adjust space between Latin and Asian text, Adjust space between Asian text and numbers, Tab stops: Not at 19.85 pt + 39.7 pt + 59.55 pt + 79.4 pt + 99.25 pt + 119.05 pt + 138.9 pt + 158.75 pt + 178.6 pt + 198.45 pt

where

- f is the percentage deformation;
- x is the distance between the starting and final positions of the pressure peg;
- c is the distance between the boxed centres

Field Code Changed

Check that the sunglass frame shows no fracture.

6.1.3.4 The sunglass frames shall be inspected, without the aid of magnification, by a trained observer. During the examination, expose the test sample to an illuminance of 1 000 lx to 2 000 lx and carry out the inspection against a matt black background. Check that neither filter has been dislodged wholly or partially dislodged from its original location in the groove or mount.

6.1.4 Report

Report whether

- a) the residual deformation of the sunglass, f , exceeded 2 %,
- b) the maximum load of 5 N achieved the distance specified in 6.1.3.1 b),
- c) the frame shows any fracture or crack and
- d) either filter has been dislodged wholly or partially from its original location in the groove or mount.

Formatted: Pattern: Clear

6.1.5 Uncertainty of measurement

An estimate of the uncertainty of measurement associated with this method of test shall be established in accordance with [ISO/IEC Guide 98-3](#). The value of this estimate shall not exceed $\pm 10\%$ and shall be applied to the result in accordance with [Annex A](#).

NOTE The use of transfer standards can assist in establishing common uncertainties of measurement between laboratories.

6.2 Test method for increased endurance of sunglasses

6.2.1 Principle

The test aims to simulate the strains on the sunglass frame, particularly the joints, when putting the sunglasses on or off. The end of one side is clamped to restrain lateral and prevent rotational movement while the end of the other is rotated through a circle of diameter 60 mm. The bridge is supported, but not clamped, by an artificial nose to restrict movement of the frame.

6.2.2 Apparatus

6.2.2.1 Overall scheme, the test apparatus consists of two clamping devices mounted on universal joints, which are used to move the sides relative to each other, a bridge support and a revolution counter.

The positions of the clamps and bridge support, relative to each other, shall be adjustable by at least 40 mm horizontally and vertically.

The apparatus shall be capable of continuously and smoothly imparting a cyclical motion to one of the universal joints:

- down ($30 \pm 0,5$) mm;
- out ($60 \pm 1,0$) mm;
- up ($30 \pm 0,5$) mm;

at a rate of 40 cycles/min, with the other clamped side remaining fixed, except for the flexure of the universal joint.

For testing in frame development, manufacturers may modify the test equipment so that either the right or the left side is subject to the cyclical motion, the other remaining fixed.

6.2.2.2 Clamping devices, mounted on universal joints, are used to restrain the sides (see [Figures 2](#) and [4](#)). The universal joints shall not restrict the angular movement of the sides. The clamping point, specified as the edge of the clamp nearest the axis of the joint (hinge) or dowel screw axis, shall be (55 ± 1) mm from the centre of the pivot of the universal joint.

6.2.2.3 Bridge support, formed from a horizontal bar of triangular cross-section, enclosing an angle of $(30^\circ \pm 2)^\circ$ and having a thickness at the top of (12 ± 1) mm with the upper edge approximately radiused (see [Figure 3](#), key item 2).

6.2.2.4 Revolution counter, used to count the number of cycles imparted to one of the spectacle sides.

Formatted: Pattern: Clear

Formatted: Pattern: Clear

Formatted: Pattern: Clear

Formatted: Pattern: Clear

Formatted: Pattern: Clear

iTeh STANDARD PREVIEW
(standards.iteh.ai)

ISO/FDIS 12311
<https://standards.iteh.ai/catalog/standards/sist/63592122-f820-45dc-a7fa-eed92af6278d/iso-fdis-12311>

Formatted: Pattern: Clear

Formatted: Pattern: Clear