**Rubber- or plastics-coated
fabrics — Determination of fogging
characteristics of trim materials in the
interior of automobiles**

*Textiles revêtus de caoutchouc ou de plastique — Détermination des
caractéristiques d'embuage des matériaux de garnissage utilisés dans
l'habitacle automobile*

iTeh STANDARD PREVIEW
(standards.iteh.ai)

[ISO/PRF 6452](https://standards.iteh.ai/catalog/standards/sist/1ea0d8f2-67ad-4489-a867-94fafc9e5e93/iso-prf-6452)

<https://standards.iteh.ai/catalog/standards/sist/1ea0d8f2-67ad-4489-a867-94fafc9e5e93/iso-prf-6452>

PROOF / ÉPREUVE



Reference number
ISO 6452:2021(E)

© ISO 2021

iTeh STANDARD PREVIEW (standards.iteh.ai)

ISO/PRF 6452

<https://standards.iteh.ai/catalog/standards/sist/1ea0d8f2-67ad-4489-a867-94fafc9e5e93/iso-prf-6452>



COPYRIGHT PROTECTED DOCUMENT

© ISO 2021

All rights reserved. Unless otherwise specified, or required in the context of its implementation, no part of this publication may be reproduced or utilized otherwise in any form or by any means, electronic or mechanical, including photocopying, or posting on the internet or an intranet, without prior written permission. Permission can be requested from either ISO at the address below or ISO's member body in the country of the requester.

ISO copyright office
CP 401 • Ch. de Blandonnet 8
CH-1214 Vernier, Geneva
Phone: +41 22 749 01 11
Email: copyright@iso.org
Website: www.iso.org

Published in Switzerland

Contents

	Page
Foreword.....	iv
1 Scope	1
2 Normative references	1
3 Terms and definitions	1
4 Principle	1
5 Materials	2
6 Apparatus	2
7 Test pieces and test samples	5
8 Conditioning	5
9 Procedure	7
9.1 Cleaning.....	7
9.1.1 General.....	7
9.1.2 Cleaning with a dishwasher.....	7
9.2 Reference tests.....	7
9.3 Arrangement of test pieces and samples.....	7
9.4 Measurements prior to the fogging test.....	8
9.5 Fogging test.....	8
9.5.1 Set-up.....	8
9.5.2 Determination of fogging value, F	8
9.5.3 Determination of mass of condensable constituents, G	9
10 Expression of results	9
10.1 Fogging value.....	9
10.2 Mass of the condensable constituents.....	9
11 Precision	10
12 Test report	10
Annex A (informative) Precision	11
Annex B (informative) Comparison between air chamber and oil bath test results	14
Bibliography	15

Foreword

ISO (the International Organization for Standardization) is a worldwide federation of national standards bodies (ISO member bodies). The work of preparing International Standards is normally carried out through ISO technical committees. Each member body interested in a subject for which a technical committee has been established has the right to be represented on that committee. International organizations, governmental and non-governmental, in liaison with ISO, also take part in the work. ISO collaborates closely with the International Electrotechnical Commission (IEC) on all matters of electrotechnical standardization.

The procedures used to develop this document and those intended for its further maintenance are described in the ISO/IEC Directives, Part 1. In particular, the different approval criteria needed for the different types of ISO documents should be noted. This document was drafted in accordance with the editorial rules of the ISO/IEC Directives, Part 2 (see www.iso.org/directives).

Attention is drawn to the possibility that some of the elements of this document may be the subject of patent rights. ISO shall not be held responsible for identifying any or all such patent rights. Details of any patent rights identified during the development of the document will be in the Introduction and/or on the ISO list of patent declarations received (see www.iso.org/patents).

Any trade name used in this document is information given for the convenience of users and does not constitute an endorsement.

For an explanation of the voluntary nature of standards, the meaning of ISO specific terms and expressions related to conformity assessment, as well as information about ISO's adherence to the World Trade Organization (WTO) principles in the Technical Barriers to Trade (TBT), see www.iso.org/iso/foreword.html.

This document was prepared by Technical Committee ISO/TC 45, *Rubber and rubber products*, Subcommittee SC 04, *Products (other than hoses)*. [ISO/PRF 6452](https://standards.iteh.ai/catalog/standards/sist/1ea0d8f2-67ad-4489-a867-6465f0e51366-iso-6452)

This third edition cancels and replaces the second edition (ISO 6452:2007), which has been technically revised.

The main changes compared to the previous edition are as follows:

- air has been added as a suitable thermal transfer fluid for the test apparatus;
- a new [Annex B](#) on comparison between air chamber and oil bath test results has been added;
- precision data in [Annex A](#) have been updated with the results of an interlaboratory test program (ITP) carried out in 2019-2020.

Any feedback or questions on this document should be directed to the user's national standards body. A complete listing of these bodies can be found at www.iso.org/members.html.

Rubber- or plastics-coated fabrics — Determination of fogging characteristics of trim materials in the interior of automobiles

WARNING — Persons using this document should be familiar with normal laboratory practice. This document does not purport to address all of the safety problems, if any, associated with its use. It is the responsibility of the user to establish appropriate safety and health practices and to ensure compliance with any national regulatory conditions.

1 Scope

This document specifies a test method which is intended to determine the fogging characteristics of rubber- or plastics-coated fabrics that are used as trim materials in the interior of motor vehicles.

The method can also apply to fluid, pasty, powdered or solid raw materials which are the basis for such trim materials or from which the materials are manufactured. The method can also apply to other materials and finished products.

The procedure is applicable to the measurement of fog condensate on glass surfaces within the limits of the test conditions. This test cannot measure accurately those cases in which:

- the surface tension of the condensate is low, resulting in early coalescing into a thin transparent film;
- the condensate is present in such a large quantity that the droplets coalesce and form a heavy oily/clear film (this heavy film gives false readings).

In such cases, the gravimetric method is preferred.

2 Normative references

The following documents are referred to in the text in such a way that some or all of their content constitutes requirements of this document. For dated references, only the edition cited applies. For undated references, the latest edition of the referenced document (including any amendments) applies.

ISO 2813, *Paints and varnishes — Determination of gloss value at 20°, 60° and 85°*

3 Terms and definitions

No terms and definitions are listed in this document.

ISO and IEC maintain terminological databases for use in standardization at the following addresses:

- ISO Online browsing platform: available at <https://www.iso.org/obp>
- IEC Electropedia: available at <http://www.electropedia.org/>

4 Principle

A test piece or portion is heated in a glass beaker. Any volatile constituents are condensed on either a cooled glass plate or a disc of cooled aluminium foil.

The fogging value F is calculated as the quotient, in percent, of the gloss value for the glass plate with fogging condensate and the gloss value of the same glass plate without fogging condensate. The gloss values are measured in accordance with ISO 2813.

The mass of the condensable constituents G is given by the difference between the masses of the aluminium foil disc before and after fogging.

5 Materials

5.1 Thermal transfer fluid, liquid or air, for the thermostatically controlled bath or chamber (6.1). The fluid shall be temperature-stable and preferably water-soluble for easier cleaning. A suitable fluid is a modified polyhydric aliphatic alcohol or air.

5.2 Glass-cleaning detergent, of a non-alkaline type.

5.3 Reference liquid, diisodecyl phthalate (DIDP)¹⁾.

6 Apparatus

6.1 Thermostatically controlled bath or chamber, designed to operate at up to 130 °C. Safety devices shall be fitted to prevent overheating. The circulation system, the bath or chamber capacity and the heating system shall be such that the temperature can be kept constant to within $\pm 0,5$ °C throughout the bath or chamber. The agitation of the bath or chamber shall be done at a slow and uniform speed.

NOTE 1 It is very important to keep the temperature correct, as tests have shown that only a 0,5 °C difference can be seen in the test results.

NOTE 2 Some heaters/circulators have a centrifugal pump in the bottom, pumping the liquid at high speed around the bath. The beakers (6.3) will then have the liquid passing them at different speeds and this will cause different temperatures in different beakers.

NOTE 3 Comparison between air chamber and oil bath test results is described in Annex B for reference.

The bath or chamber shall be designed so that, after placing the beakers (6.3) in the bath or chamber, the temperature does not drop more than 5 °C, and the test temperature is regained after no more than 20 min. The minimum distance between the beakers and the walls shall be 30 mm and between the bottom of the bath and the beakers 60 mm.

The bath or the chamber shall be equipped with a device indicating the distance between the fluid and the lower surface of the glass plate (6.6). This distance shall be (60 ± 2) mm.

6.2 Cooling plates, designed to be placed on the glass plate (6.6) to keep them cool. The cooling plate shall be hollow and made of corrosion-resistant metal, with the side facing the glass plate made of aluminium. They shall have two cooling-water connections located so that the cooling water flows through the whole of the interior of the plate. The surface in contact with the glass plate shall be flat. When using liquid for thermal transfer fluid, the mass of a cooling plate filled with water shall be at least 1 kg, to overcome the buoyancy of the beaker (6.3) in the bath. The whole of the weight of the cooling plate shall rest on the beaker. A separate cooling plate shall be used for each beaker.

The cooling plate and the associated water thermostat shall be designed so that the mean water temperature is 21 °C and the difference in temperature between the inlet and outlet does not exceed 1 °C.

6.3 Flat-bottomed beakers, of heat-resistant glass, minimum mass 400 g, with the dimensions shown in Figure 1.

1) DIDP reference liquid can be obtained from: SP Technical Research Institute of Sweden, Chemistry and Materials Technology, Box 857, SE-501 15 Borås, Sweden, Fax: +46 33 10 33 88, E-mail: info@sp.se. This information is given for the convenience of users of this document and does not constitute an endorsement by ISO of the product named.

Dimensions in millimetres

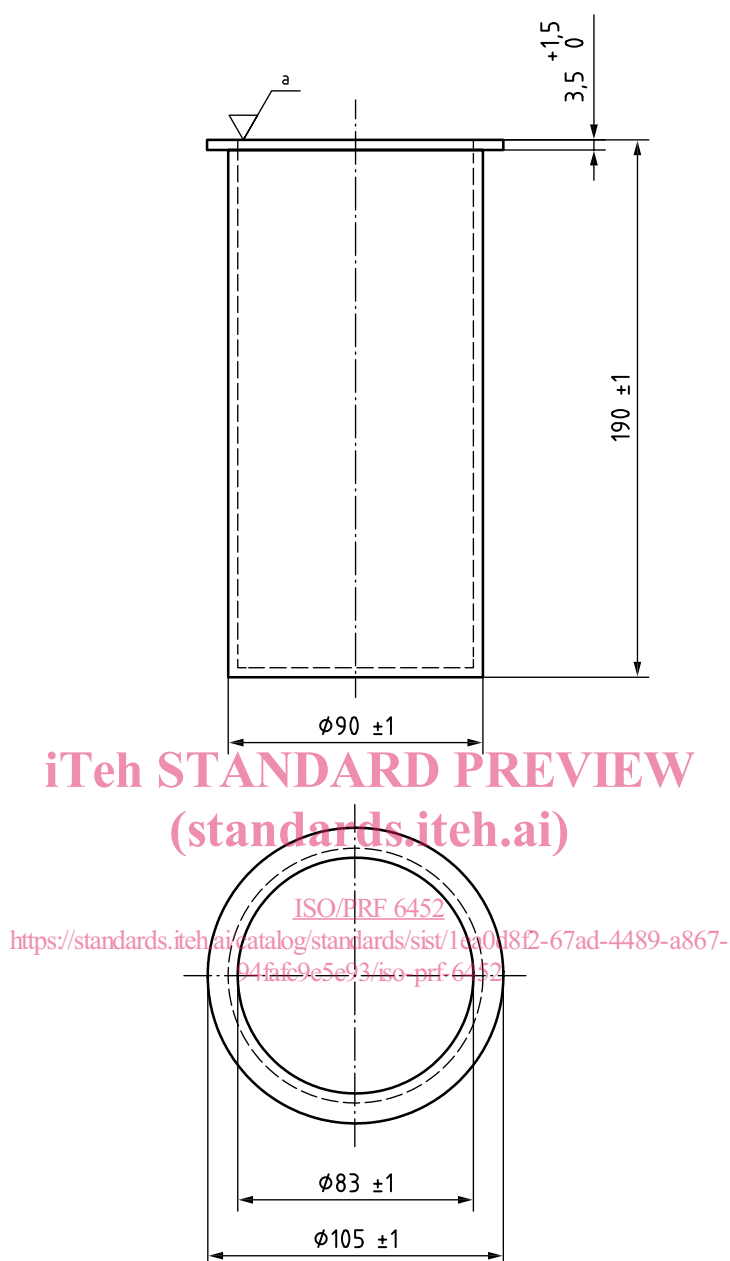

^a Ground.

Figure 1 — Glass beaker

6.4 Metal rings, external diameter 80 mm, internal diameter 74 mm, height 10 mm and mass (55 ± 1) g, made of corrosion-protected steel, to keep the test pieces flat.

6.5 Sealing rings, of silicone- or fluoro-rubber, L-shaped or circular in cross-section, inner diameter 90 mm to 95 mm, thickness 2 mm to 4 mm and hardness 50 IRHD to 70 IRHD.

6.6 Float glass plates, of residential or windshield window quality, for condensation of the fogging, thickness $(3 \pm 0,2)$ mm, either square with minimum dimensions of (110×110) mm or circular with a diameter of 103 mm. The gloss values of all the plates used shall be the same to within ± 2 % units. The tin and non-tin surfaces of the plate shall be identified and the identification mark shall be placed on the plate.

NOTE The tin and non-tin surfaces of the glass plate can be identified by viewing the surface in a darkened room under a UV light at 254 nm wavelength. The tin surface fluoresces when it is exposed to the UV light.

6.7 **Filter paper**, with a diameter of 110 mm and a mass per unit surface area of 90 g/m².

6.8 **Aluminium foil discs**, thickness 0,03 mm, diameter (103 ± 1) mm. Store the prepared aluminium foil disc in a desiccator (6.15) to avoid condensation and contamination.

6.9 **Gloss meter**, with a 60° incident beam and 60° measurement beam in accordance with ISO 2813.

6.10 **Spacer**, designed to prevent contact with the condensate on the glass plate during gloss meter measurements, made of a suitable material such as paper or plastic with a circular hole for the measurements. The thickness of the spacer shall be (0,1 ± 0,02) mm (see Figure 2).

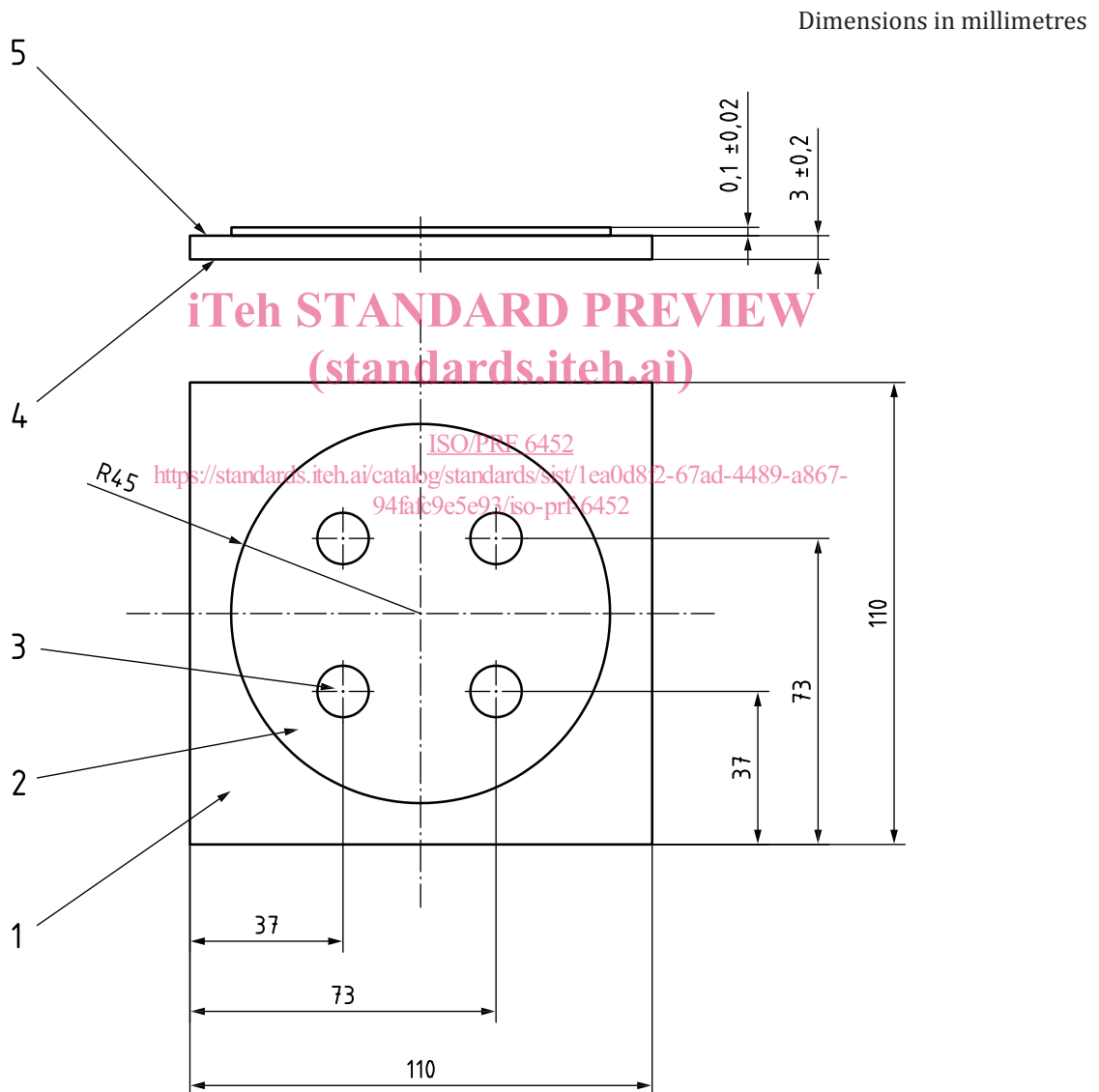

Key

- | | |
|---------------------------------------|----------------------------------|
| 1 float glass plate | 4 tin surface of glass plate |
| 2 spacer | 5 non-tin surface of glass plate |
| 3 circular holes for the measurements | |

Figure 2 — Example of a spacer on top of glass plate

6.11 Dishwasher, preferably connected to a deionized-water supply and capable of being operated at 80 °C.

6.12 Balance, with scale divisions of 0,01 mg.

6.13 Polyethylene gloves.

6.14 Tongs.

6.15 Desiccator, with suitable drying material.

An example of a test apparatus is shown in [Figure 3](#).

7 Test pieces and test samples

In the case of finished products, cut circular test pieces with a diameter of (80 ± 1) mm from the sample. The thickness of the test pieces can be up to 10 mm. Machine thicker materials on the underside to 10 mm (the underside is the side facing away from the side which is visible in the vehicle). If other test piece dimensions are required, these may be as given in the product specification or as agreed between the interested parties.

In the case of powdered, pasty or fluid materials, take a $(10 \pm 0,1)$ g test portion of the sample.

Take two test pieces or portions for the determination of the fogging value *F* and another two for the determination of the mass of the condensable constituents *G*.

8 Conditioning

ISO/PRF 6452

Unless otherwise specified, condition all test pieces or portions at 23 °C and 50 % RH for at least 16 h.

Foamed materials and coated fabrics shall be conditioned by drying in accordance with [Table 1](#) in a desiccator over phosphorus pentoxide (or silica gel) on a carrier, without the use of a vacuum.

Table 1 — Drying times

Material	Drying time days
Foamed materials	1
Coated fabrics	2
Materials with a high water content (e.g. leather)	7

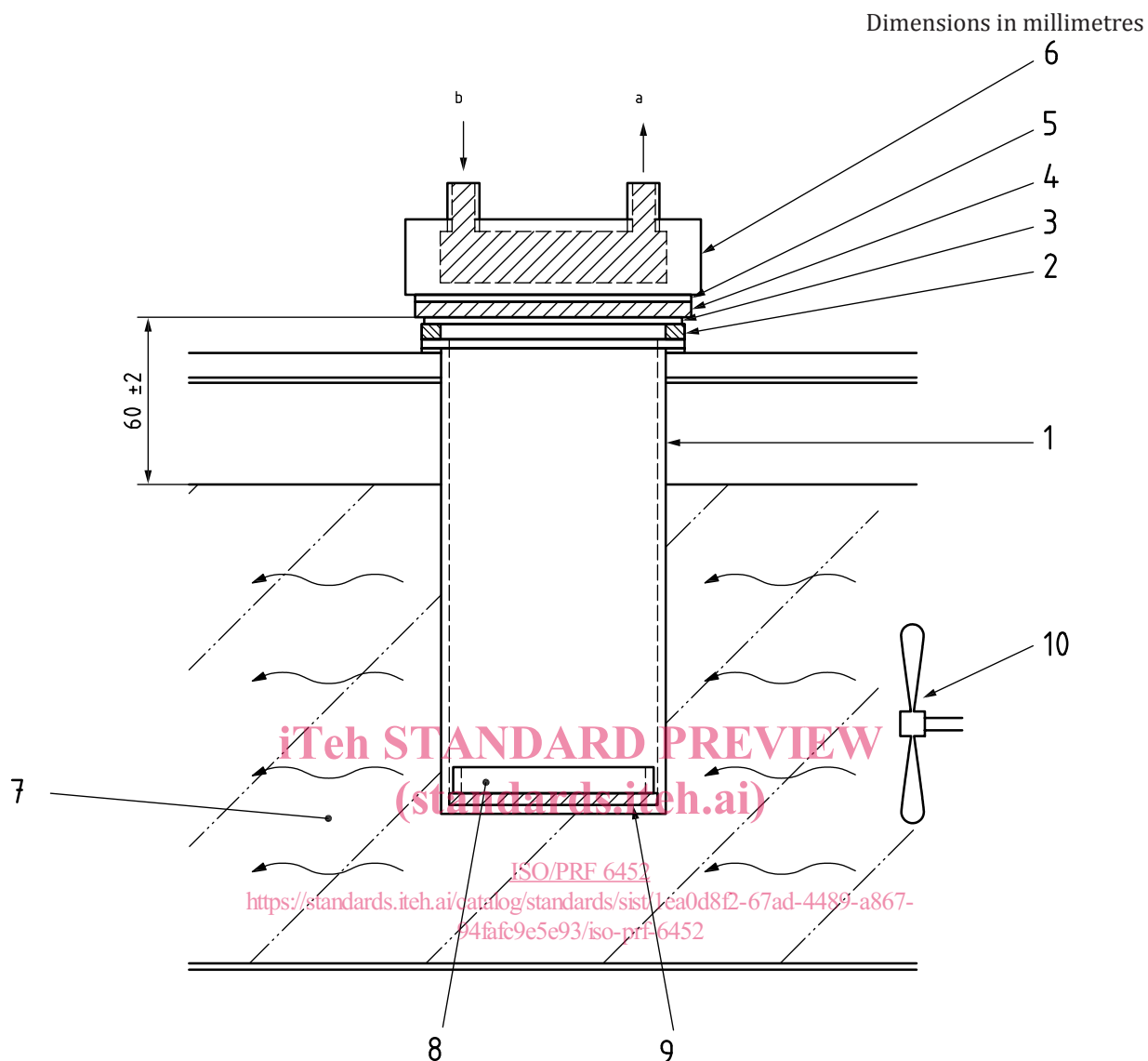

Key

- | | |
|---|---|
| <p>1 beaker</p> <p>2 sealing ring</p> <p>3 aluminium foil disc
(determination of mass of condensable constituents <i>G</i> test only)</p> <p>4 float glass plate</p> <p>5 filter paper</p> <p>6 cooling plate</p> | <p>7 thermal transfer fluid (liquid or air)</p> <p>8 metal ring (if necessary)</p> <p>9 test piece</p> <p>10 agitating fan</p> <p>a Cooling-water outlet.</p> <p>b Cooling-water inlet.</p> |
|---|---|

Figure 3 — Example of a test apparatus

9 Procedure

9.1 Cleaning

9.1.1 General

Only touch the beakers (6.3) on the outer surfaces. Do not touch the glass plates (6.6) or the metal rings (6.4) with bare hands; use gloves (6.13) or tongs (6.14).

After the glass plates have been cleaned and dried, make a visual check that the plates are free of scratches and other defects; if they are not, discard them.

After cleaning, store all items, the beakers upside-down, in a dust-free environment at room temperature until the measurements are made.

9.1.2 Cleaning with a dishwasher

Wash the sealing rings (6.5), beakers and metal rings twice in a dishwasher (6.11) with glass-cleaning detergent (5.2). If the dishwasher is not connected to a deionized-water supply, rinse the cleaned equipment in deionized water.

Prior to each use, clean all glass plates twice in the dishwasher at 80 °C using a glass-cleaning detergent. If the dishwasher is not connected to a deionized-water supply, rinse the cleaned glass plates in deionized water at room temperature and dry them in an upright position.

It is recommended that the glass plates are not reused more than a few times, since microscopic scratches may affect the rate of deposition of any vapours and hence the reproducibility of the method. Discard any glass plates that have surface scratches or abraded spots.

NOTE Tests have shown that it is very important to use a neutral or acid detergent as alkaline detergent affects the glass surface and the fogging value calculated from gloss values increases.

9.2 Reference tests

In parallel with every fogging test, carry out a reference test to determine the fogging value F of the reference liquid DIDP (5.3). For this purpose, add $(10 \pm 0,1)$ g of DIDP to a beaker, taking care not to moisten the inner wall of the beaker. Place the beaker with the DIDP in the bath or chamber (6.1), using a different position for each test. After the test period of (180 ± 3) min at the bath or chamber temperature of $(100 \pm 0,5)$ °C, the fogging value shall be within 76 to 98. If this is not the case, check the test conditions.

Carry out the same procedure with DIDP when determining the mass of the condensable constituents G . After the test period of $(16 \pm 0,2)$ h at the bath or chamber temperature of $(100 \pm 0,5)$ °C, the mass of the condensable constituents shall be within 0,40 mg to 0,90 mg. If this is not the case, check the test conditions.

NOTE It is very important not to moisten the walls of the beaker with the DIDP when handling the beaker, as this will give a larger area with DIDP and a higher test result.

9.3 Arrangement of test pieces and samples

Insert the test pieces or portions into beakers (one test piece or portion per beaker). Do not touch the test pieces or portions with bare hands.

Place the test pieces so that the visible side, i.e. the side facing the vehicle interior, faces upwards. If necessary to prevent rolling and warping of the test pieces, place a metal ring on each.

When testing powdered, pasty or fluid materials, use a $(10 \pm 0,1)$ g test portions of the sample, uniformly distributing it over the bottom of the inside of the beaker.