



Designation: ~~D5853-09~~ Designation: D5853 - 11



Designation: 441/99

Standard Test Method for Pour Point of Crude Oils¹

This standard is issued under the fixed designation D5853; the number immediately following the designation indicates the year of original adoption or, in the case of revision, the year of last revision. A number in parentheses indicates the year of last reapproval. A superscript epsilon (ϵ) indicates an editorial change since the last revision or reapproval.

1. Scope*

1.1 This test method covers two procedures for the determination of the pour point temperatures of crude oils down to -36°C . Procedure A provides a measure of the maximum (upper) pour point temperature and is described in 9.1. Procedure B provides a measure of the minimum (lower) pour point temperature and is described in 9.2.

1.2 The use of this test method is limited to use for crude oils. Pour point temperatures of other petroleum products can be determined by Test Method D97.

1.3 The values stated in SI units are to be regarded as standard. No other units of measurement are included in this standard.
1.4

1.4 **WARNING**—Mercury has been designated by many regulatory agencies as a hazardous material that can cause central nervous system, kidney and liver damage. Mercury, or its vapor, may be hazardous to health and corrosive to materials. Caution should be taken when handling mercury and mercury containing products. See the applicable product Material Safety Data Sheet (MSDS) for details and EPA's website—<http://www.epa.gov/mercury/faq.htm>—for additional information. Users should be aware that selling mercury and/or mercury containing products into your state or country may be prohibited by law.

1.5 *This standard does not purport to address all of the safety concerns, if any, associated with its use. It is the responsibility of the user of this standard to establish appropriate safety and health practices and determine the applicability of regulatory limitations prior to use.* For specific hazard statements, see Section 7.

2. Referenced Documents

2.1 ASTM Standards:²

D97 Test Method for Pour Point of Petroleum Products

D130 Test Method for Corrosiveness to Copper from Petroleum Products by Copper Strip Test

D323 Test Method for Vapor Pressure of Petroleum Products (Reid Method)

D4057 Practice for Manual Sampling of Petroleum and Petroleum Products

D4177 Practice for Automatic Sampling of Petroleum and Petroleum Products

E1 Specification for ASTM Liquid-in-Glass Thermometers

E77 Test Method for Inspection and Verification of Thermometers

3. Terminology

3.1 Definitions of Terms Specific to This Standard:

3.1.1 *maximum (upper) pour point, n*—the pour point obtained after the test specimen has been subjected to a prescribed treatment designed to enhance gelation of wax crystals and solidification of the test specimen.

3.1.2 *minimum (lower) pour point, n*—the pour point obtained after the test specimen has been subjected to a prescribed treatment designed to delay gelation of wax crystals and solidification of the test specimen.

3.1.3 *pour point, n*—the lowest temperature at which movement of the test specimen is observed under the conditions of the test.

¹ This test method is under the jurisdiction of ASTM Committee D02 on Petroleum Products and Lubricants and is the direct responsibility of Subcommittee D02.07 on Flow Properties.

Current edition approved April 15, 2009. Published May 2009. Originally approved in 1995. Last previous edition approved in 2006 as D5853-06. DOI: 10.1520/D5853-09.

Current edition approved June 1, 2011. Published July 2011. Originally approved in 1995. Last previous edition approved in 2009 as D5853-09. DOI: 10.1520/D5853-11.

² For referenced ASTM standards, visit the ASTM website, www.astm.org, or contact ASTM Customer Service at service@astm.org. For *Annual Book of ASTM Standards* volume information, refer to the standard's Document Summary page on the ASTM website.

*A Summary of Changes section appears at the end of this standard.

4. Summary of Test Method

4.1 After preliminary heating, the test specimen is cooled at a specified rate and examined at intervals of 3°C for flow characteristics. The lowest temperature at which movement of the test specimen is observed is recorded as the pour point.

5. Significance and Use

5.1 The pour point of a crude oil is an index of the lowest temperature of handleability for certain applications.

5.2 This is the only pour point method specifically designed for crude oils.

5.3 The maximum and minimum pour point temperatures provide a temperature window where a crude oil, depending on its thermal history, might appear in the liquid as well as the solid state.

5.4 The test method can be used to supplement other measurements of cold flow behavior. It is especially useful for the screening of the effect of wax interaction modifiers on the flow behavior of crude oils.

6. Apparatus

6.1 *Pour Point Test Apparatus Assembly (see Fig. 1):*

6.1.1 *Test Jar*, cylindrical, of clear glass, flat bottomed, outside diameter 33.2 to 34.8 mm, and height 115 to 125 mm. The inside diameter of the jar can range from 30.0 to 32.4 mm, within the constraint that the wall thickness shall be no greater than 1.6 mm. The jar shall have a line to indicate a sample height 54 ± 3 mm above the inside bottom. The inside of the test jar (up to the mark) shall be visibly clean and free of scratches.

6.1.2 *Thermometers*, having ranges shown in the following table and conforming to the requirements prescribed in Specification E1 for thermometers:

Thermometer	Temperature Range	Thermometer	
		ASTM	Number
High cloud and pour	-38 to +50°C	5C	1C
Low cloud and pour	-80 to +20°C	6C	2C
Melting point	+32 to +127°C	61C	63C

6.1.2.1 Since separation of liquid column thermometers occasionally occurs and may escape detection, the ice point of the thermometers shall be checked prior to the test and used only if they are accurate within $\pm 1^\circ\text{C}$ (see Test Method E77).

6.1.3 *Cork*, to fit the test jar, center bored for the test thermometer.

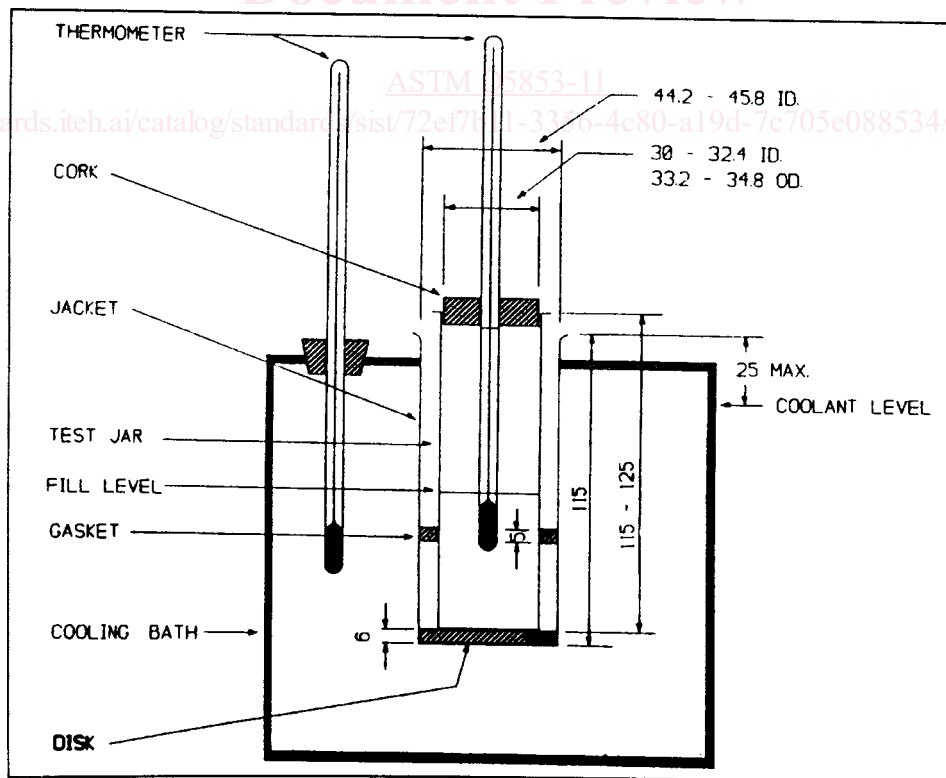

NOTE—All dimensions are stated in millimetres.

FIG. 1 Apparatus for Pour Point Test

6.1.4 *Jacket*, watertight, cylindrical, metal, flat bottomed, 115 ± 3 mm depth, with inside diameter of 44.2 to 45.8 mm. It shall be supported in a vertical position in the cooling bath (6.1.7) so that no more than 25 mm projects out of the cooling medium. The jacket shall be capable of being cleaned.

6.1.5 *Disk*, cork or felt, 6 mm thick to fit loosely inside the jacket.

6.1.6 *Gasket*, to fit snugly around the outside of the test jar and loosely inside the jacket. The gasket shall be made of rubber, leather, or other material that is sufficiently elastic to cling to the test jar and hard enough to hold its shape. Its purpose is to prevent the test jar from touching the jacket.

6.1.7 *Cooling Bath or Baths*, of a type suitable for obtaining the required temperatures. The size and shape of the bath are options, but a support to hold the jacket firmly in a vertical position is essential. The bath temperature shall be monitored by means of the appropriate thermometer (6.1.2) or any other temperature measuring device capable of measuring and displaying the designated temperature with the required precision and accuracy. The required bath temperatures shall either be obtained by refrigeration or by suitable cooling mixtures and shall maintain the designated temperatures to within ±1.5°C. Cooling mixtures commonly used for bath temperatures are shown in Table 1.

6.2 *Water Bath*—The size and shape of the bath are optional, but a support to hold the test jar immersed in the bath to above the sample height in the test jar and in a firm vertical position is required. The required bath temperature may be maintained by any suitable means, provided the temperature can be monitored and controlled to the designated temperature (±1°C (9.1.4; 9.2.4)).

6.3 *Pressure Vessel*, constructed of stainless steel according to the dimensions given in Fig. 2, and capable of withstanding a test pressure of 700 kPa. Alternative designs for the pressure vessel cap and synthetic rubber gasket may be used provided that the internal dimensions of the pressure vessel are the same as those shown in Fig. 2.

NOTE 1—This pressure vessel is identical to the pressure vessel described in Test Method D130.

6.4 *Timing Device*, capable of measuring up to 30 s with a resolution of at least 0.1 s and an accuracy of ±0.2 s or better.

7. Reagents and Materials

7.1 The following solvents of technical grade are appropriate for low-temperature bath media.

7.1.1 *Acetone*, (**Warning**—Extremely flammable.)

7.1.2 *Petroleum Naphtha*, (**Warning**—Combustible. Vapor harmful.)

NOTE 2—Typical petroleum naphtha used for cleaning purposes are VM and P naphthas.

7.2 *Toluene*, technical grade (**Warning**—Flammable. Vapor harmful.)

7.3 *Solid Carbon Dioxide*, (**Warning**—Extremely cold (−78.5°C).)

7.4 *Sodium Chloride Crystals*—Commercial or technical grade sodium chloride is suitable.

TABLE 1 Cooling Mixtures and Bath Temperatures

	Bath Temperature
Ice and water	0 ± 1.5°C
Crushed ice and sodium chloride crystals or Acetone or petroleum naphtha (see Section 7) with solid carbon dioxide added to give the desired temperature	−18 ± 1.5°C
Crushed ice and sodium chloride crystals or Acetone or petroleum naphtha or methanol or ethanol (see Section 7) with solid carbon dioxide added to give the desired temperature	−18 ± 1.5°C
Acetone or petroleum naphtha (see Section 7) with solid carbon dioxide added to give the desired temperature	−33 ± 1.5°C
Acetone or petroleum naphtha or methanol or ethanol (see Section 7) with solid carbon dioxide added to give the desired temperature	−33 ± 1.5°C
Acetone or petroleum naphtha (see Section 7) with solid carbon dioxide added to give the desired temperature	−51 ± 1.5°C
Acetone or petroleum naphtha or methanol or ethanol (see Section 7) with solid carbon dioxide added to give the desired temperature	−51 ± 1.5°C
Acetone or petroleum naphtha (see Section 7) with solid carbon dioxide added to give the desired temperature	−69 ± 1.5°C
Acetone or petroleum naphtha or methanol or ethanol (see Section 7) with solid carbon dioxide added to give the desired temperature	−69 ± 1.5°C

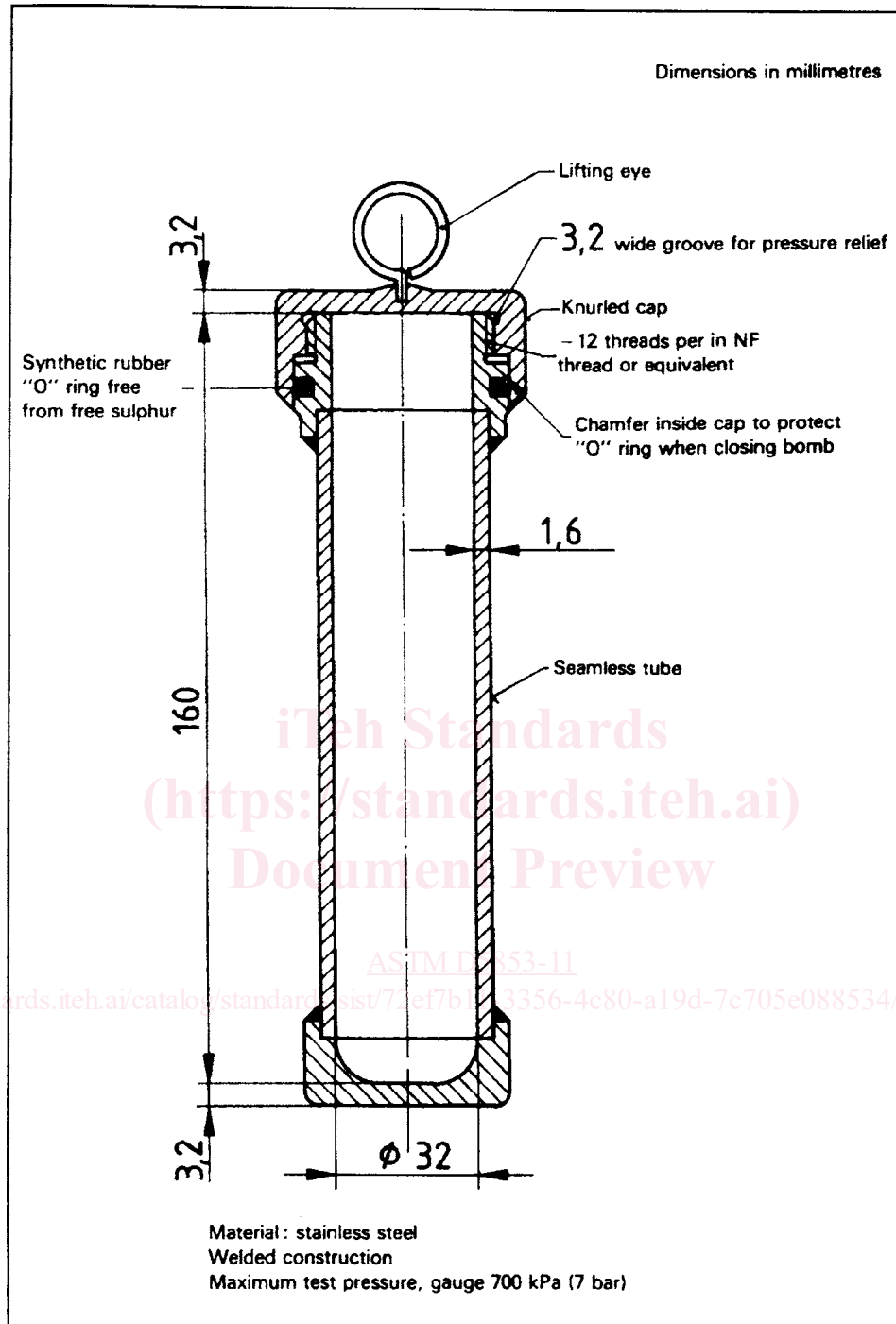

FIG. 2 Pressure Vessel

7.5 Ethanol or Ethyl Alcohol—A commercial or technical grade of dry ethanol is suitable for the cooling bath. (**Warning**—Flammable. Denatured. Cannot be made nontoxic.)

7.6 Methanol or Methyl Alcohol—A commercial or technical grade of dry methanol is suitable for the cooling bath. (**Warning**—Flammable. Vapor harmful.)

8. Sampling, Test Samples, and Test Specimens

NOTE 3—Sampling is defined as all steps required to obtain a portion of the contents of any pipe, tank, or other system and to place the sample into the laboratory test container.

8.1 *Laboratory Sample*—It is essential that the sample received by the laboratory is representative of the batch or lot of crude oil from which it was taken. Practices D4057 and D4177 provide guidance for obtaining such representative samples.