

INTERNATIONAL  
STANDARD

ISO  
24045

First edition

---

---

**Ships and marine technology —  
Adjustable roller-type chain stoppers**

**iTeh STANDARD PREVIEW**  
**(standards.iteh.ai)**

[ISO/PRF 24045](https://standards.iteh.ai/catalog/standards/sist/fede89cb-f655-4356-9f26-83be3d19c171/iso-prf-24045)

<https://standards.iteh.ai/catalog/standards/sist/fede89cb-f655-4356-9f26-83be3d19c171/iso-prf-24045>

**PROOF / ÉPREUVE**

---

---



Reference number  
ISO 24045:2021(E)

© ISO 2021

## iTeh STANDARD PREVIEW (standards.iteh.ai)

ISO/PRF 24045

<https://standards.iteh.ai/catalog/standards/sist/fede89cb-f655-4356-9f26-83be3d19c171/iso-prf-24045>



### **COPYRIGHT PROTECTED DOCUMENT**

© ISO 2021

All rights reserved. Unless otherwise specified, or required in the context of its implementation, no part of this publication may be reproduced or utilized otherwise in any form or by any means, electronic or mechanical, including photocopying, or posting on the internet or an intranet, without prior written permission. Permission can be requested from either ISO at the address below or ISO's member body in the country of the requester.

ISO copyright office  
CP 401 • Ch. de Blandonnet 8  
CH-1214 Vernier, Geneva  
Phone: +41 22 749 01 11  
Email: [copyright@iso.org](mailto:copyright@iso.org)  
Website: [www.iso.org](http://www.iso.org)

Published in Switzerland

# Contents

	Page
Foreword .....	iv
<b>1 Scope .....</b>	<b>1</b>
<b>2 Normative references .....</b>	<b>1</b>
<b>3 Terms and definitions .....</b>	<b>1</b>
<b>4 Design, strength and safety requirements .....</b>	<b>2</b>
<b>5 Function and operation requirements .....</b>	<b>2</b>
<b>6 Structure .....</b>	<b>3</b>
<b>7 Materials .....</b>	<b>6</b>
<b>8 Acceptance .....</b>	<b>7</b>
<b>9 Marking .....</b>	<b>7</b>
<b>Annex A (normative) Strength calculations of adjustable roller-type chain stoppers .....</b>	<b>8</b>
<b>Annex B (informative) Precautions for manufacturers of adjustable roller-type chain stopper .....</b>	<b>14</b>

## iTeh STANDARD PREVIEW (standards.iteh.ai)

[ISO/PRF 24045](https://standards.iteh.ai/catalog/standards/sist/fede89cb-f655-4356-9f26-83be3d19c171/iso-prf-24045)

<https://standards.iteh.ai/catalog/standards/sist/fede89cb-f655-4356-9f26-83be3d19c171/iso-prf-24045>

## Foreword

ISO (the International Organization for Standardization) is a worldwide federation of national standards bodies (ISO member bodies). The work of preparing International Standards is normally carried out through ISO technical committees. Each member body interested in a subject for which a technical committee has been established has the right to be represented on that committee. International organizations, governmental and non-governmental, in liaison with ISO, also take part in the work. ISO collaborates closely with the International Electrotechnical Commission (IEC) on all matters of electrotechnical standardization.

The procedures used to develop this document and those intended for its further maintenance are described in the ISO/IEC Directives, Part 1. In particular the different approval criteria needed for the different types of ISO documents should be noted. This document was drafted in accordance with the editorial rules of the ISO/IEC Directives, Part 2 (see [www.iso.org/directives](http://www.iso.org/directives)).

Attention is drawn to the possibility that some of the elements of this document may be the subject of patent rights. ISO shall not be held responsible for identifying any or all such patent rights. Details of any patent rights identified during the development of the document will be in the Introduction and/or on the ISO list of patent declarations received (see [www.iso.org/patents](http://www.iso.org/patents)).

Any trade name used in this document is information given for the convenience of users and does not constitute an endorsement.

For an explanation of the voluntary nature of standards, the meaning of ISO specific terms and expressions related to conformity assessment, as well as information about ISO's adherence to the World Trade Organization (WTO) principles in the Technical Barriers to Trade (TBT), see [www.iso.org/iso/foreword.html](http://www.iso.org/iso/foreword.html).

This document was prepared by Technical Committee ISO/TC 8, *Ships and marine technology*, Subcommittee SC 4, *Outfitting and deck machinery*.

Any feedback or questions on this document should be directed to the user's national standards body. A complete listing of these bodies can be found at [www.iso.org/members.html](http://www.iso.org/members.html).

# Ships and marine technology — Adjustable roller-type chain stopper

## 1 Scope

This document specifies requirements for the design, strength, safety, function and operation of adjustable roller-type chain stoppers. It also specifies their structure, materials, acceptance and marking.

It is applicable to the design, manufacture and acceptance of adjustable roller-type chain stoppers.

## 2 Normative references

The following documents are referred to in the text in such a way that some or all of their content constitutes requirements of this document. For dated references, only the edition cited applies. For undated references, the latest edition of the referenced document (including any amendments) applies.

ISO 1704, *Ships and marine technology — Stud-link anchor chains*

ISO 3828, *Shipbuilding and marine structures — Deck machinery — Vocabulary and symbols*

ISO 4568, *Shipbuilding — Sea-going vessels — Windlass and anchor capstan*

ISO 6325, *Shipbuilding — Cable stoppers*

ISO 7825, *Shipbuilding — Deck machinery — General requirements*  
ISO/PRF 24045  
<https://standards.iteh.ai/catalog/standards/sist/edeb9cb-1655-4356-9f26-83be3d19c171/iso-prf-24045>

## 3 Terms and definitions

For the purpose of this document, the terms and definitions given in ISO 3828 and ISO 4568 and the following apply.

ISO and IEC maintain terminological databases for use in standardization at the following addresses:

- ISO Online browsing platform: available at <https://www.iso.org/obp>
- IEC Electropedia: available at <https://www.electropedia.org/>

### 3.1 adjustable roller-type chain stopper

device fixed to the ship structure, separated from the gypsy wheel and used for fixing the anchor chain and for bearing the anchor tension

Note 1 to entry: After being installed on the ship structure, the position of the lever can be adjusted according to the stowing condition of the anchor chain to achieve a better stowing effect. It can guide the anchor chain. When the anchor chain passes on the chain guide groove and the roller, the anchor chain can be guided.

### 3.2 right-hand adjustable roller-type chain stopper

adjustable roller-type chain stopper that is opened and fixed on the right-hand side, when viewed from the gypsy wheel to the chain stopper

### 3.3

#### **left-hand adjustable roller-type chain stopper**

adjustable roller-type chain stopper that is opened and fixed on the left-hand side, when viewed from the gypsy wheel to the chain stopper

## 4 Design, strength and safety requirements

**4.1** The adjustable roller-type chain stopper shall be designed and manufactured to withstand a load without permanent deformation in accordance with the requirements of ISO 6325 for Class A cable stoppers. The load shall be 80 % of the nominal breaking load of the anchor chain corresponding diameter.

**4.2** The nominal sizes of the anchor chain shall be in accordance with ISO 1704, Grade 3.

**4.3** Adjustable roller-type chain stoppers shall meet the general requirements of ISO 7825 for deck machinery and the specific requirements of [4.4](#) and [4.5](#).

**4.4** The design stress of the load specified in [4.1](#) shall not exceed the yield stress of the material used. The adjustable roller-type chain stopper shall be designed to prevent the generation of high bending moments in the chain link. The strength calculations for adjustable roller-type chain stoppers shall be according to [Annex A](#).

**4.5** The lever of the adjustable roller-type chain stopper shall be able to reliably and effectively prevent itself from gradually moving to the open position when it is at the closed position, to avoid releasing and throwing out the anchor chain. It shall be possible to operate the lever conveniently and to fix it reliably when at the open position.

**4.6** Precautions for manufacturers of adjustable roller-type chain stoppers are given in [Annex B](#).

## 5 Function and operation requirements

**5.1** The adjustable roller-type chain stopper shall be installed between the windlass and the hawse pipe, which can effectively control the anchor chain during ship navigation, lock the anchor chain during ship anchoring, and can bear 80 % of the nominal breaking load of the corresponding anchor chain.

**5.2** The operation of the adjustable roller-type chain stopper shall be convenient and safe. Locking devices shall be installed on parts that can cause danger to the operator due to unintentional actions.

**5.3** Under no load, it shall be possible to manually operate the adjustable roller-type chain stopper. The operating force of an anchor chain with a diameter of less than 84 mm shall not exceed 350 N, and that of an anchor chain with a diameter of 84 mm or above shall not exceed 500 N.

## 6 Structure

6.1 The structure of adjustable roller-type chain stoppers is shown in Figure 1, and their main dimensions are given in Table 1.

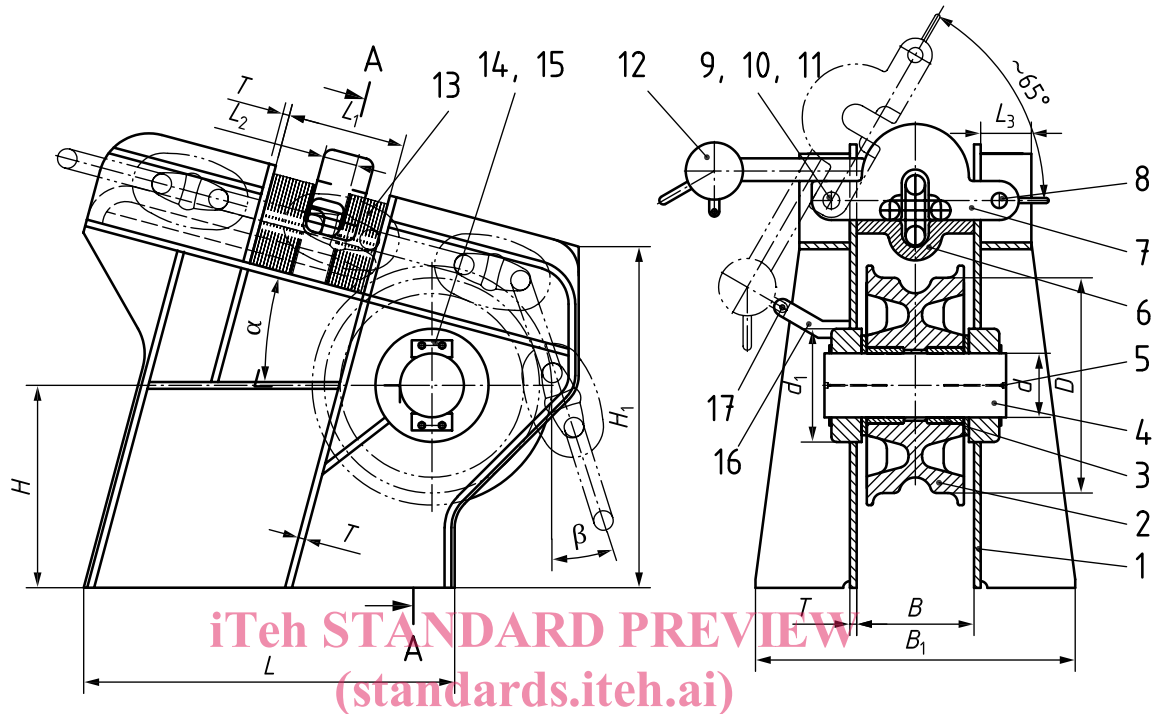

### Key

1	support	ISO/PRF 24045	washer
2	roller	<a href="https://standards.iteh.ai/catalog/standards/sist/fede89cb-855-4356-9f26-83be3d19c171/iso-prf-24045">https://standards.iteh.ai/catalog/standards/sist/fede89cb-855-4356-9f26-83be3d19c171/iso-prf-24045</a>	11 cotter pin
3	bushing		12 balance weight
4	shaft		13 adjust block
5	oil cup		14 stop plate
6	chain guide groove		15 bolts
7	lever		16 balance weight fixed seat
8	pin		17 tonguing pin
9	pin shaft		

NOTE The figure shows a left-hand adjustable roller-type chain stopper, to which the right-hand type is symmetrical.

Figure 1 — Structure of adjustable roller-type chain stoppers

Table 1 — Main dimensions of adjustable roller-type chain stoppers

Nominal size	Anchor chain size	B	B <sub>1</sub>	D	d <sup>a</sup>	d <sub>1</sub>	L	L <sub>1</sub>	L <sub>2</sub>	L <sub>3</sub>	H	H <sub>1</sub>	T	Mass
		mm	mm	mm	mm	mm	mm	mm	mm	mm	mm	mm	mm	kg
52	50 to 52	306	850	560	170	300	1 060	340	110	125	480	910	20	~1 340
56	54 to 56	326	896	600	185	310	1 120	365	115	135	540	980	20	~1 700
60	58 to 60	348	948	640	195	320	1 220	390	125	150	600	1 010	20	~2 100

<sup>a</sup> When  $\alpha + \beta > 35^\circ$ , the diameter of the shaft can be reduced appropriately, which needs to be determined according to calculation.

The dimensions in the table are for reference only and should be based on the results of strength calculation.

Table 1 (continued)

Nominal size	Anchor chain size	B mm	B <sub>1</sub> mm	D mm	d <sup>a</sup> mm	d <sub>1</sub> mm	L mm	L <sub>1</sub> mm	L <sub>2</sub> mm	L <sub>3</sub> mm	H mm	H <sub>1</sub> mm	T mm	Mass kg
64	62 to 64	380	1 020	680	210	330	1 340	415	145	160	630	1 100	22	~2 300
68	66 to 68	405	1 072	720	220	350	1 420	450	165	170	650	1 150	24	~2 810
73	70 to 73	428	1 116	760	235	370	1 580	480	185	180	670	1 190	24	~3 450
78	76 to 78	452	1 174	810	250	400	1 650	510	200	185	680	1 230	26	~4 050
84	81 to 84	476	1 228	870	265	440	1 700	540	220	190	700	1 270	26	~4 800
90	87 to 90	518	1 314	930	285	450	1 760	560	230	200	720	1 320	28	~5 200
95	92 to 95	542	1 378	980	295	460	1 820	580	240	210	740	1 400	28	~5 500
102	97 to 102	570	1 466	1 040	310	470	1 900	610	250	220	760	1 480	32	~5 800
107	105 to 107	600	1 560	1 090	320	480	2 020	630	260	230	780	1 550	32	~6 900
114	111 to 114	630	1 642	1 160	335	500	2 100	650	265	240	800	1 680	36	~8 300
122	117 to 122	664	1 780	1 260	365	550	2 300	690	280	260	850	1 800	38	~12 000

<sup>a</sup> When  $\alpha + \beta > 35^\circ$ , the diameter of the shaft can be reduced appropriately, which needs to be determined according to calculation.

The dimensions in the table are for reference only and should be based on the results of strength calculation.

6.2 The roller of adjustable roller-type chain stoppers is shown in Figure 2, and its main dimensions are given in Table 2.

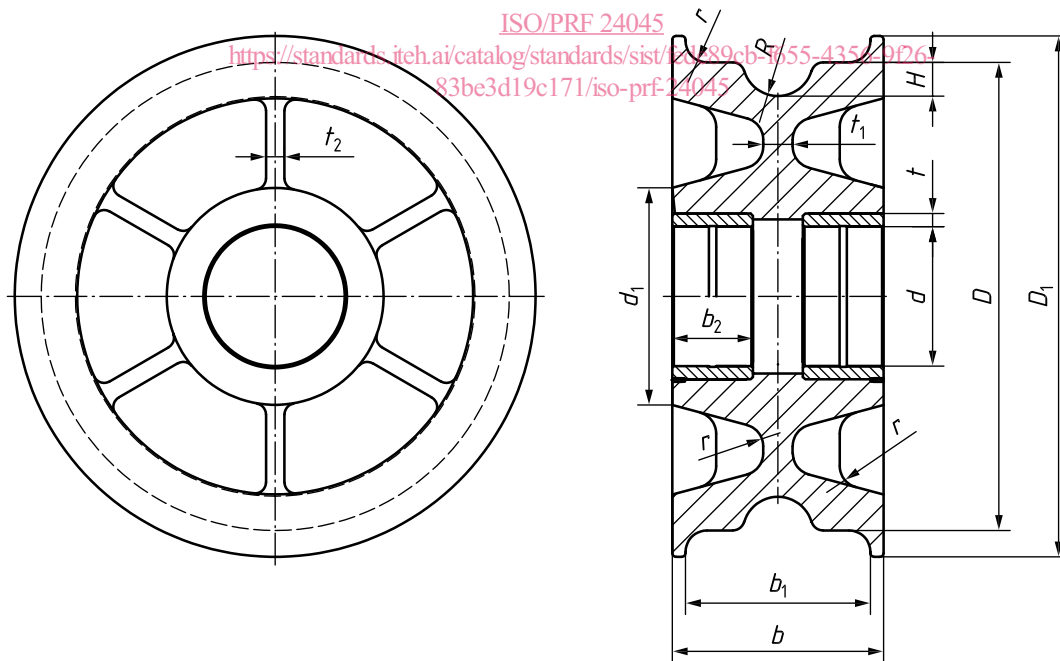

Figure 2 — Roller of adjustable roller-type chain stoppers



Table 2 — Main dimensions of the roller of adjustable roller-type chain stoppers

Nominal size	Anchor chain size	$D$ mm	$D_1$ mm	$b$ mm	$b_1$ mm	$b_2$ mm	$d$ mm	$d_1$ mm	$t$ mm	$t_1$ mm	$t_2$ mm	$R$ mm	$r$ mm	$H^a$	Mass kg
52	50 to 52	560	624	250	225	95	170	260	15	38	26	42	26	0,78 to 1,8 times the diam- eter of the an- chor chain	~250
56	54 to 56	600	670	270	242	100	185	276	15	38	26	45	29		~320
60	58 to 60	640	714	288	260	110	195	292	16	40	28	48	31		~410
64	62 to 64	680	768	320	280	120	210	306	16	42	28	52	33		~560
68	66 to 68	720	810	340	295	130	220	320	16	46	30	56	35		~610
73	70 to 73	760	850	362	315	138	235	346	18	50	32	60	37		~730
78	76 to 78	810	906	384	335	145	250	360	18	52	34	64	39		~875
84	81 to 84	870	970	408	360	150	265	376	18	54	38	68	42		~1 240
90	87 to 90	930	1 040	442	390	160	285	410	20	56	40	72	45		~1 327
95	92 to 95	980	1 090	466	410	176	295	420	20	58	42	76	48		~1 540
102	97 to 102	1 040	1 160	486	430	185	310	440	20	60	42	80	51		~1 800
107	105 to 107	1 090	1 210	512	455	194	320	454	22	62	44	84	53		~2 080
114	111 to 114	1 160	1 290	536	480	204	335	468	22	64	44	90	56		~2 430
122	117 to 122	1 260	1 400	580	525	220	365	510	24	68	46	94	62	~2 970	

<sup>a</sup>  $H$  is the depth of the roller anchor chain groove.

If  $\alpha + \beta = 15^\circ$  to  $25^\circ$ , it is taken as 0,78 to 0,80 times the diameter of the anchor chain;

if  $\alpha + \beta = 26^\circ$  to  $35^\circ$ , it is taken as 0,86 to 0,87 times the diameter of the anchor chain;

if  $\alpha + \beta = 36^\circ$  to  $45^\circ$ , it is taken as 1,15 to 1,17 times the diameter of the anchor chain;

if  $\alpha + \beta = 46^\circ$  to  $55^\circ$ , it is taken as 1,21 to 1,22 times the diameter of the anchor chain;

if  $\alpha + \beta > 56^\circ$ , it is taken as 1,7 to 1,8 times the diameter of the anchor chain.

The dimensions in the table are for reference only and should be based on the results of strength calculation.

6.3 The lever of adjustable roller-type chain stoppers is shown in Figure 3, and its main dimensions are given in Table 3.

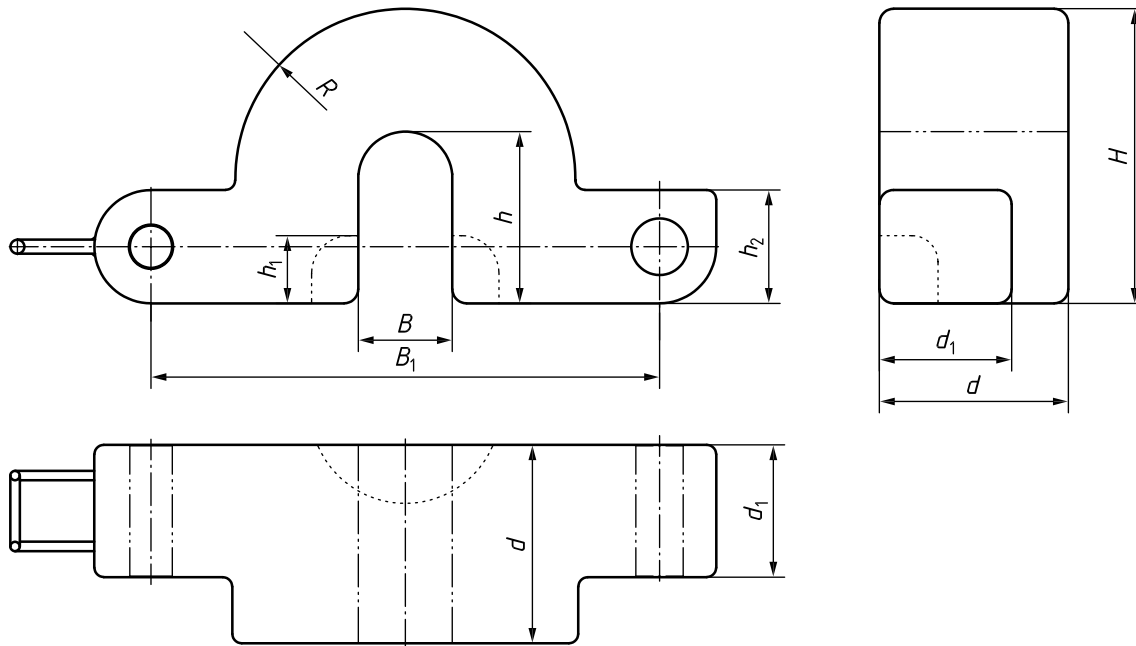

Figure 3 — Lever of adjustable roller-type chain stoppers

(standards.iteh.ai)

Table 3 — Main dimensions of the lever of adjustable roller-type chain stoppers

Nominal size	Anchor chain size mm	B mm	B <sub>1</sub> mm	d mm	d <sub>1</sub> mm	H mm	h mm	h <sub>1</sub> mm	h <sub>2</sub> mm	R mm	Mass kg
52	50 to 52	86	472	160	105	260	150	65	100	153	~79
56	54 to 56	96	502	170	110	284	168	68	105	164	~95
60	58 to 60	106	540	185	120	298	178	72	110	173	~123
64	62 to 64	110	586	210	140	310	185	76	120	180	~165
68	66 to 68	118	626	220	160	335	204	82	130	190	~195
73	70 to 73	126	658	235	180	353	218	88	140	195	~234
78	76 to 78	136	690	250	195	376	234	94	160	210	~305
84	81 to 84	146	720	260	210	402	250	100	180	225	~380
90	87 to 90	156	776	278	220	430	262	108	185	246	~413
95	92 to 95	162	810	290	230	445	270	114	190	256	~464
102	97 to 102	170	848	300	240	470	285	120	195	270	~527
107	105 to 107	180	890	315	250	495	295	126	200	290	~585
114	111 to 114	186	940	320	255	507	300	134	205	300	~641
122	117 to 122	200	1 020	340	270	550	330	156	220	320	~750

NOTE The dimensions in the table are for reference only and should be based on the results of strength calculation.

## 7 Materials

7.1 Weldable steel with a minimum yield strength of 235 N/mm<sup>2</sup> or a steel of equivalent strength shall be used for the supports, pin shafts, pins, balance weights, adjusting blocks and stop plates.

7.2 Steel with a minimum yield strength of 550 N/mm<sup>2</sup> shall be used for the shafts.

7.3 Steel with a minimum yield strength of 350 N/mm<sup>2</sup> shall be used for the levers.

7.4 Steel castings with a minimum yield strength of 235 N/mm<sup>2</sup> shall be used for the rollers and chain guide grooves, whose carbon content shall not exceed 0,23 %.

## 8 Acceptance

Adjustable roller-type chain stoppers shall be visually inspected at the manufacturing site to ensure that:

- a) the stop device works normally;
- b) the roller rolls flexibly;
- c) the surface is smooth and free edge rounded, and steel castings have no cracks, sand holes, air holes or other defects affecting the strength;
- d) the welding parts have no such defects as welding leakage, air holes or undercuts.

## 9 Marking

Adjustable roller-type chain stoppers conforming to this document shall be permanently marked with the following elements:

- a) name: adjustable roller-type chain stopper;
- b) a reference to this document: ISO 24045:2021;
- c) applicable anchor chain normal diameter: XXX;
- d) anchor chain grade: AM3;
- e) left-hand or right-hand chain stopper: L or R.

EXAMPLE An adjustable roller-type chain stopper conforming to this document, with a diameter of 100 mm, a Grade 3 anchor chain and a left-hand chain stopper is marked as follows:

**Adjustable roller-type chain stopper ISO 24045:2021-100-AM3-L**