



Designation: C1382 – 11

# Standard Test Method for Determining Tensile Adhesion Properties of Sealants When Used in Exterior Insulation and Finish Systems (EIFS) Joints<sup>1</sup>

This standard is issued under the fixed designation C1382; the number immediately following the designation indicates the year of original adoption or, in the case of revision, the year of last revision. A number in parentheses indicates the year of last reapproval. A superscript epsilon ( $\epsilon$ ) indicates an editorial change since the last revision or reapproval.

## 1. Scope

1.1 This test method describes a laboratory procedure for measuring tensile adhesion properties of sealants to exterior insulation and finish systems (EIFS) under dry, wet, frozen, heat-aged, and artificial weather-aged conditions.

1.2 The committee with jurisdiction over this standard is not aware of any comparable standards published by other organizations.

1.3 The values stated in SI units are to be regarded as the standard. The inch-pound values given in parentheses are provided for information only.

1.4 *This standard does not purport to address all of the safety concerns, if any, associated with its use. It is the responsibility of the user of this standard to establish appropriate safety and health practices and determine the applicability of regulatory limitations prior to use.*

1.5 The committee with jurisdiction over this standard is not aware of any comparable standards published by other organizations.

## 2. Referenced Documents

2.1 *ASTM Standards:*<sup>2</sup>

[C717 Terminology of Building Seals and Sealants](#)

[C1135 Test Method for Determining Tensile Adhesion Properties of Structural Sealants](#)

[C1442 Practice for Conducting Tests on Sealants Using Artificial Weathering Apparatus](#)

[E177 Practice for Use of the Terms Precision and Bias in ASTM Test Methods](#)

[E631 Terminology of Building Constructions](#)

[E691 Practice for Conducting an Interlaboratory Study to Determine the Precision of a Test Method](#)

[G113 Terminology Relating to Natural and Artificial Weathering Tests of Nonmetallic Materials](#)

[G151 Practice for Exposing Nonmetallic Materials in Accelerated Test Devices that Use Laboratory Light Sources](#)

[G154 Practice for Operating Fluorescent Ultraviolet \(UV\) Lamp Apparatus for Exposure of Nonmetallic Materials](#)

[G155 Practice for Operating Xenon Arc Light Apparatus for Exposure of Non-Metallic Materials](#)

## 3. Terminology

3.1 *Definitions:*

3.1.1 Refer to Terminology [C717](#) for definitions of the following terms used in this test method: adhesion failure, cohesive failure, primer, sealant, and substrate.

3.1.2 Refer to Terminology [G113](#) for definitions of terms relating to natural and artificial weathering.

3.2 *Description of Terms Specific to This Standard*—refer to Terminology [E631](#) for definitions of the following terms used in this test method: base coat, EIFS, and finish coat.

## 4. Summary of Test Method

4.1 This test method is a modification of Test Method [C1135](#). Preliminary testing using Test Method [C794](#) may be helpful as a screen test to determine dry adhesion capabilities and priming requirements before proceeding with this test. This test is performed after the specimen assemblies are subjected to a variety of conditions that artificially accelerate the effect of weathering impact on the sealant-to-EIFS bond. The conditioning employed in this test does not necessarily address all field conditions.

## 5. Significance and Use

5.1 EIFS are barrier-type systems that must be weather-proofed to prevent the passage of moisture, air, dust, heat, and cold from entering a structure.

5.2 This test method is intended to determine the adhesion properties of the sealant with the EIFS substrate as determined by its tensile adhesive properties for dry, wet, frozen, heat-aged, and artificial weather-aged conditions.

<sup>1</sup> This test method is under the jurisdiction of ASTM Committee [C24](#) on Building Seals and Sealants and is the direct responsibility of Subcommittee [C24.30](#) on Adhesion.

Current edition approved July 1, 2011. Published August 2011. Originally approved in 1997. Last previous edition approved in 2005 as C1382–05. DOI: 10.1520/C1382-11.

<sup>2</sup> For referenced ASTM standards, visit the ASTM website, www.astm.org, or contact ASTM Customer Service at service@astm.org. For *Annual Book of ASTM Standards* volume information, refer to the standard's Document Summary page on the ASTM website.

## 6. Apparatus and Materials

6.1 *Tensile Testing Machine*—Capable of producing a tensile load on the specimen at the rate of  $50 \pm 5$  mm ( $2.0 \pm 0.20$  in.)/min., and with a recording chart to show stress/strain values (tensile modulus).

6.1.1 *Fixed Member*—A fixed or essentially stationary member carrying one grip.

6.1.2 *Movable Member*—A movable member carrying a second grip.

6.1.3 *Grips*—The grips should be suitable to firmly grasp the test fixture that holds the test specimen and should be designed to eliminate eccentric specimen loading. Specimen loading should be perpendicular to the substrate/sealant interfaces. For alignment purposes, each grip shall have a swivel or universal joint at the end nearest to the specimen.

6.1.4 *Grip Fixture*—A fixture capable of being held by the grips and furnishing a tensile force to the sealant specimen.

6.2 *Spatulas*—For use in applying sealant.

6.3 *Caulking Gun*—For extruding sealant from cartridges, when applicable.

6.4 *Primer*, if applicable.

6.5 *Sealant*.

6.6 *Spacer*—One piece of spacer made from polytetrafluoroethylene (PTFE) or a suitable rigid material shall be used to which the test sealant will not bond.

6.7 *Knife*, with sharp razor-type blade.

6.8 *Masking Tape*.

6.9 *EIFS substrates*, as identified in 10.1.5.

6.10 *Rigid substrate*, for applying EIFS coating in the peel adhesion test.

6.11 *Waterproof membrane*, such as molten paraffin.

6.12 *Freezer*,  $-18 \pm 2^\circ\text{C}$  ( $0 \pm 3.6^\circ\text{F}$ ).

6.13 *Oven*,  $70 \pm 2^\circ\text{C}$  ( $158 \pm 3.6^\circ\text{F}$ ).

6.14 *Exposure Apparatus*—Choice of type of apparatus shall be by mutual agreement among the interested parties. Because of differences in test conditions, test results may differ with the type of apparatus used. Consult Practices G154 and G155 for differences in the spectral power distributions of the exposure sources and Practice C1442 for the differences in test parameters in the two types of apparatus specified.

6.14.1 *Fluorescent UV/Condensation Apparatus*, as described in Practice C1442, Section 7.3.

6.14.2 *Xenon Arc Light Apparatus*, as described in Practice C1442, Section 7.2.

## 7. Test Specimens

7.1 Two (2) EIFS samples are required for each test specimen assembly as shown in Fig. 1. The EIFS sample size shall be determined by the size of the test machine grips, yet they must be a minimum of 25 by 75 mm (1 by 3 in.). It may be necessary to cut the EIFS substrate into rectangles appropriately sized for the test. If cutting is required, the EIFS must be configured such that three of the four long ends of the EIFS substrate will be coated with EIFS base or finish coat. The

remaining long end and two short ends will be uncoated EPS board with cut edges of the EIFS coating visible. In all cases, the sealant should be applied to the EIFS finish on a long side at the edge where a coated surface continues around the corner. The sealant should not be applied on the edge where coating stops and EPS board is exposed on the adjoining corner.

7.2 The EIF system being tested must be applied over minimum 25 mm (1 in.) insulation board with coating thickness consistent with the EIFS manufacturer's requirements and allowed to cure 28 days minimum at standard conditions. Select surface to be tested (for example, EIFS primer, base coat, finish coat, etc.).

NOTE 1—Five test specimen assemblies per condition should be prepared for each sealant and substrate system being tested for a total of 25 specimens per sealant/EIFS substrate combination. It may be beneficial to prepare up to five extra specimen assemblies in the event one or more samples is unusable.

7.3 Prior to assembling the test specimens, clean the surfaces to be sealed with a clean, dry, lint-free cloth or soft, nonmetallic bristle brush.

7.4 Prime surfaces (if applicable) to be sealed with appropriate primer as recommended by the sealant manufacturer. Do not allow primer to contact EPS insulation. Allow primer to dry as specified by sealant manufacturer.

7.5 Provide a 12 mm ( $\sim 1/2$  in.) spacer to form a sealant cavity centered on the test specimen measuring 12 by 12 by 50 mm ( $1/2$  by  $1/2$  by 2 in.) between the test samples. (See Fig. 1.)

7.6 Sandwich the spacer between the two test samples and secure them together with clamps or mechanical devices.

7.7 Fill each set of five test specimen assemblies with the sealant being tested and immediately strike off any excess sealant.

7.8 Identify each of the five test specimens.

7.9 Cure specimens under one of the following cycles:

7.9.1 *Standard Conditions*— $23 \pm 2^\circ\text{C}$  ( $73.4 \pm 3.6^\circ\text{F}$ ),  $50 \pm 5\%$  relative humidity for a minimum of 21 days.

7.9.2 Alternately, cure for a total of 21 days as follows: (a) 7 days at standard conditions above; (b) 7 days at  $38 \pm 2^\circ\text{C}$  ( $100 \pm 3.6^\circ\text{F}$ ) and 95 % relative humidity; (c) 7 days at standard conditions.

7.9.3 The sealant manufacturer may request conditions other than those specified provided the temperature does not exceed  $50^\circ\text{C}$  ( $122^\circ\text{F}$ ).

## 8. Conditioning

8.1 Following completion of cure as outlined in 7.9, test samples under the following conditions:

8.1.1 *Dry/Room Temperature*—Test samples at  $23 \pm 2^\circ\text{C}$  ( $73.4 \pm 3.6^\circ\text{F}$ ),  $50 \pm 5\%$  relative humidity.

8.1.2 *Water Immersion*:

8.1.2.1 Prior to immersing samples, seal perimeter edges and the outer (nonsealant surface face) of each EIFS component of the test specimen with a waterproof membrane such as molten paraffin. Do not heat the paraffin above  $65^\circ\text{C}$  ( $150^\circ\text{F}$ ) in order to avoid damage to EPS insulation. The interior facing surfaces that create the 12-mm ( $1/2$  in.) gap will not be waxed.

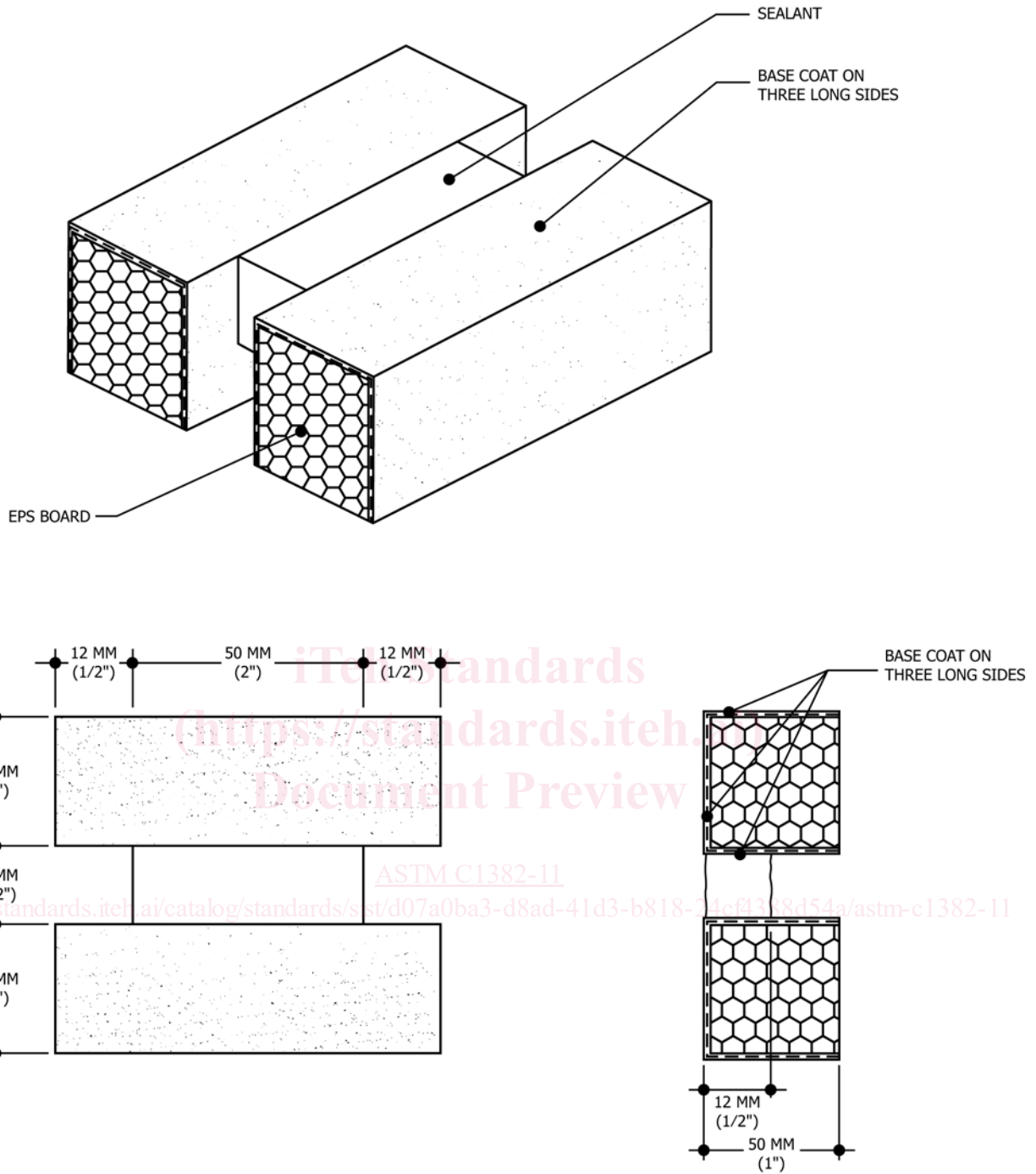

FIG. 1 Test Specimen Assembly

(See Fig. 2) Multiple dips or turns may be required to adequately cover the substrate.

8.1.2.2 Completely immerse 5 test specimen assemblies for 7 days. Weight or attach the samples so that they are completely covered to a depth of 50 mm (2 in.) with water. Test within 5 min of removal from water.

8.1.3 *Frozen*—Condition five test specimen assemblies in a  $-18 \pm 2^\circ\text{C}$  ( $0 \pm 3.6^\circ\text{F}$ ) freezer for 24 h. Remove assemblies one at a time. Test each assembly within 5 min of removal from the freezer.

8.1.4 *Heat Conditioning*—Condition five test specimen assemblies in a  $70 \pm 2^\circ\text{C}$  ( $158 \pm 3.6^\circ\text{F}$ ) oven for 24 h. Remove assemblies one at a time. Test each assembly within 5 min of removal from the oven.

8.1.5 Condition five test specimen assemblies in the artificial weathering device with the sealant surface (top of joint) facing the exposure source and positioned in accordance with the manufacturer's recommendations for specimen mounting. Specimens should be confined to an exposure area in which the irradiance is at least 90 % of the irradiance at the center of the

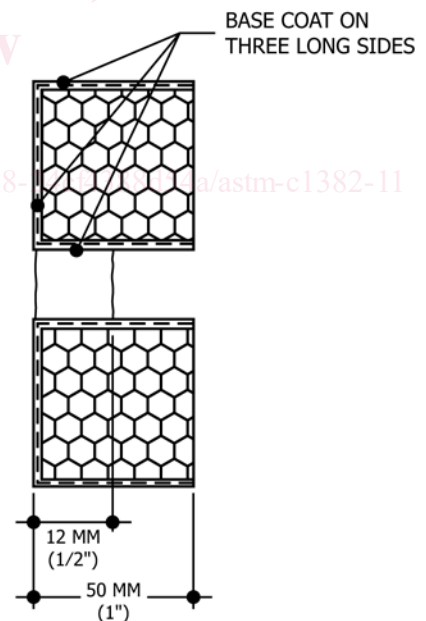
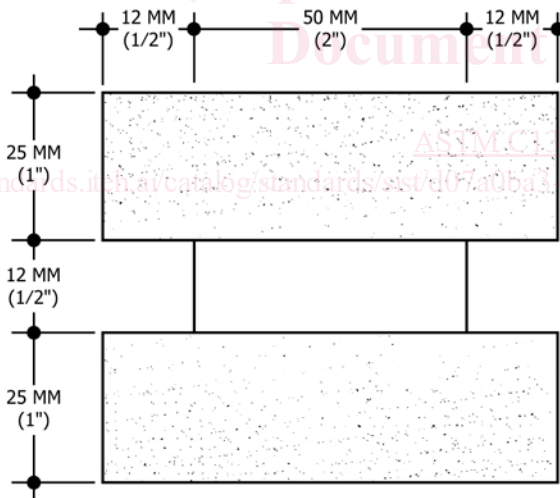
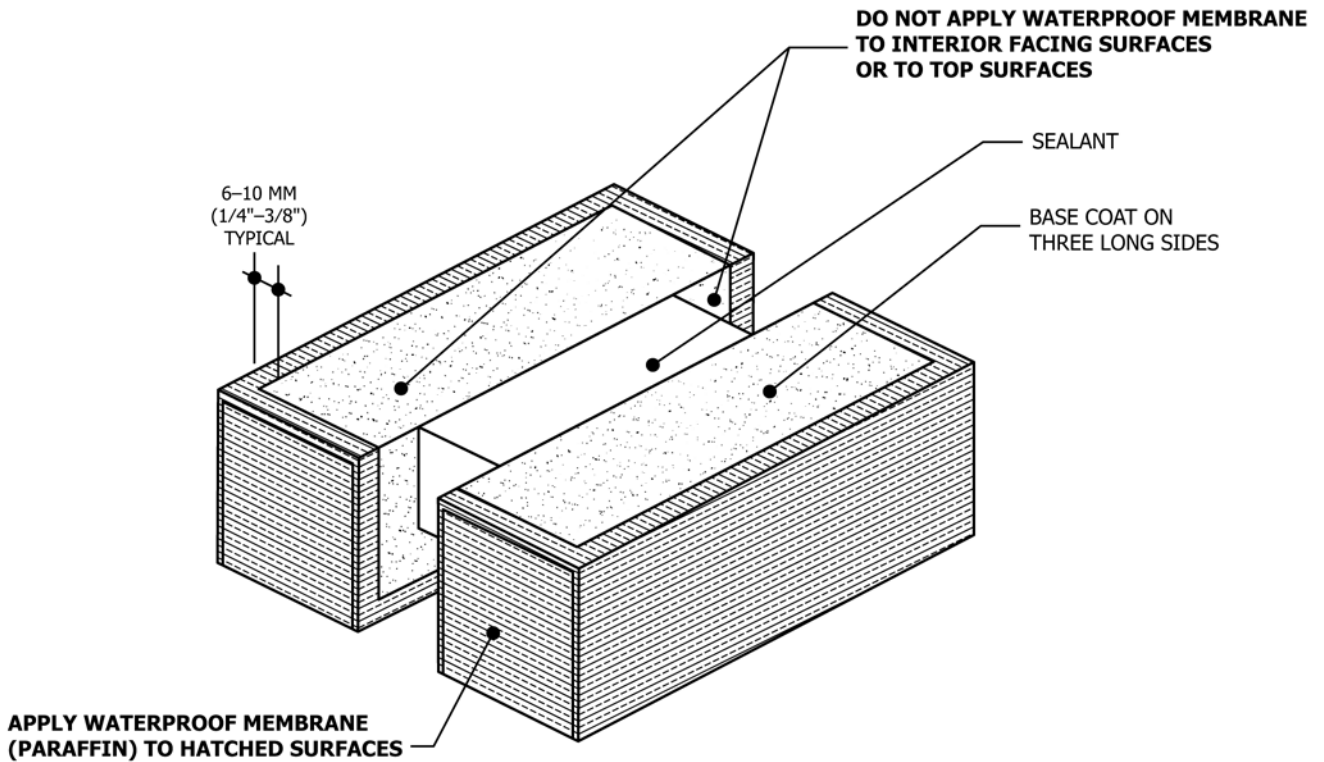

FIG. 2 Test Specimen Assembly of Water Immersion Samples

exposure area. Unless it is known that irradiance uniformity meets this requirement, use one of the procedures described in Practice G151, Section 5.1.4 to ensure equal radiant exposure on all specimens or compensation for differences within the exposure chamber. If the specimens do not completely fill the

racks, fill the empty spaces with blank metal panels to maintain the test conditions within the chamber.

8.1.5.1 Operate the fluorescent UV device in accordance with the procedure in Practice C1442, Section 7.3. Position the assemblies as shown in Fig. 3 and expose for 2500 h.

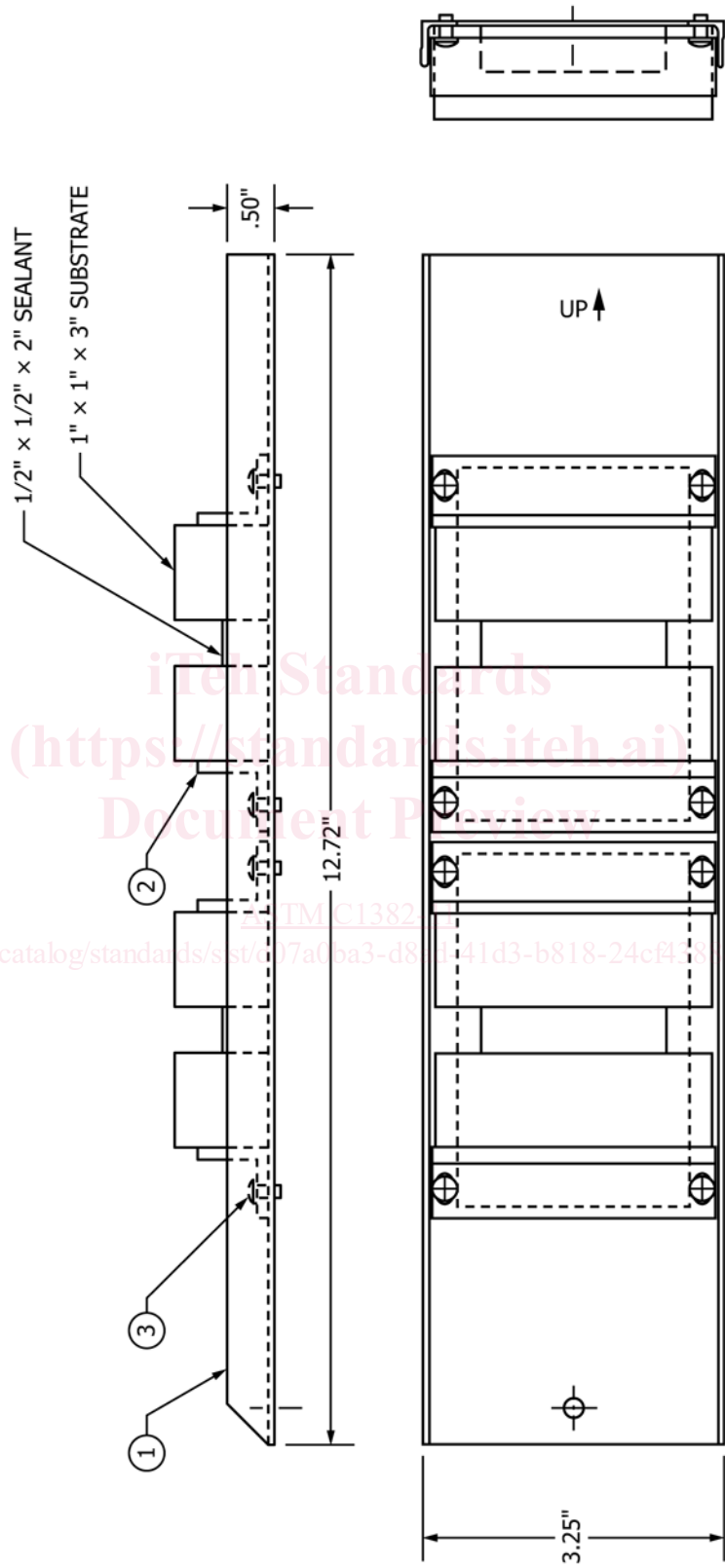

FIG. 3 Position of Test Specimens for UV/Condensation Exposure



8.1.5.2 Operate the xenon arc device in accordance with the procedure in Practice C1442, Section 7.2. The exposed face of the assemblies is positioned in accordance with the manufacturer’s recommendations for specimen mounting. Expose for 2500 h when operated at an irradiance level of 0.51 W/(m<sup>2</sup>.nm) at 340 nm. (At an irradiance level of 0.35 W/(m<sup>2</sup>.nm) at 340 nm, expose for 3643 h. See Annex A1.2.1 in Practice C1442 for the formula to calculate exposure time at other irradiance levels.)

NOTE 2—The test cycles have been used by historical convention and may not adequately simulate the effects of outdoor exposure of sealants. Other cycles can be used by mutual agreement of all concerned parties.

NOTE 3—Refer to Practice G151 for full cautionary guidance regarding laboratory weathering of nonmetallic materials.

8.1.5.3 After exposure, condition samples in laboratory for 16 h minimum at standard conditions.

**9. Procedure**

9.1 Measure and record the initial distance between the EIFS substrates prior to loading.

9.2 Place the test specimen assembly in the grips of the tensile test machine and test at a rate of 50 mm ± 5 mm (2.0 ± 0.20 in.)/min.

9.3 Record the tensile load at 10, 25, 50, and 100 % elongation (based on measurement obtained in 9.1) Other coincidence points may be recorded as desired. Stop the extension at 100 % elongation. If failure occurs prior to 100 % elongation, record elongation and tensile load at failure point.

9.4 Measure and record adhesive or cohesive failures, if either occurs.

**10. Report**

10.1 The report shall include the following information for each sample tested:

- 10.1.1 Sample identification,
- 10.1.2 Sealant identification (single versus multicomponent, color, chemical category, etc.),
- 10.1.3 Actual conditioning time as used in 8.1,
- 10.1.4 Surface preparation (if used, primer identification),
- 10.1.5 EIFS identification including base coat thickness, type, and amount of mix water. Describe surface tested (such as EIFS primer, base coat, finish coat, etc.),
- 10.1.6 Tensile Adhesion Testing Data:
  - 10.1.6.1 Tensile load in Newton’s (pounds-force) at each elongation point described in 9.3,

10.1.6.2 The percentage loss in bond and cohesion for each sample tested. Note failure mode,

10.1.6.3 Variation, if any, from the test procedure,

10.1.7 Freezer temperature,

10.1.8 Type, manufacturer and model of artificial weathering apparatus used, and

10.1.9 Irradiance level and actual time (number of hours) in weathering apparatus.

**11. Precision and Bias**

11.1 The precision of this test method is based on an interlaboratory study of Test Method C1382 conducted in 1996. Each of four laboratories tested three different sealants and three primers under varying environmental conditions. Every “test result” represents an individual determination. Each participating laboratory was instructed to submit five replicate test results for one, two, or three different sealant primer combinations. Except for the limited number of reporting laboratories, Practice E691 was followed for the design and analysis of the data; the details are given in ASTM Research Report No. C24-1059.<sup>3</sup>

11.1.1 *Repeatability Limit (r)*—Two test results obtained within one laboratory shall be judged not equivalent if they differ by more than the “r” value for that material; “r” is the interval representing the critical difference between two test results for the same material, obtained by the same operator using the same equipment on the same day in the same laboratory.

11.1.1.1 Repeatability limits are listed in Tables 1-20.

11.1.2 *Reproducibility Limit (R)*—Two test results shall be judged not equivalent if they differ by more than the “R” value for that material; “R” is the interval representing the critical difference between two test results for the same material, obtained by different operators using different equipment in different laboratories.

11.1.2.1 Reproducibility limits are listed in Tables 1-20.

11.1.3 The above terms (repeatability limit and reproducibility limit) are used as specified in Practice E177.

11.1.4 Any judgment in accordance with statements 11.1.1 and 11.1.2 would normally have an approximate 95 % probability of being correct, however the precision statistics obtained in this ILS must not be treated as exact mathematical quantities which are applicable to all circumstances and uses.

<sup>3</sup> Supporting data have been filed at ASTM International Headquarters and may be obtained by requesting Research Report RR:C24-1059.

**TABLE 1 Tensile Strength (psi) – 10 % – 21 Days Room Temperature Cure**

Sealant/ Primer	Average <sup>A</sup> psi $\bar{x}$	Number of Laborato- ries Included in Precision Calcula- tions	Repeatabil- ity Standard Deviation $S_r$	Reproduc- ibility Standard Deviation $S_R$	Repeatabil- ity Limit $r$	Reproduc- ibility Limit $R$
A/A	7.610	4	1.252	3.864	3.505	10.820
B/B	5.656	4	0.634	3.849	1.774	10.778
C/C	9.700	3	1.753	7.413	4.909	20.756

<sup>A</sup>The average of the laboratories’ calculated averages.