



# SLOVENSKI STANDARD

## SIST EN 17665:2022+A1:2023

01-maj-2023

Nadomešča:  
SIST EN 17665:2022

---

**Embalaža - Preskusne metode in zahteve za dokazovanje, da plastični pokrovčki ostanejo pritrjeni na posode za pijačo**

Packaging - Test methods and requirements to demonstrate that plastic caps and lids remain attached to beverage containers

Verpackung - Prüfverfahren und Anforderungen, die nachweisen, dass Kunststoffverschlüsse von Getränkebehältern am Behälter angebunden bleiben

Emballage - Méthodes d'essai et exigences pour démontrer que les bouchons et les couvercles en plastique restent attachés aux récipients pour boissons

**Ta slovenski standard je istoveten z: EN 17665:2022+A1:2023**

---

**ICS:**

55.100      Steklenice. Lonci. Kozarci      Bottles. Pots. Jars

**SIST EN 17665:2022+A1:2023**      en,fr,de



EUROPEAN STANDARD

EN 17665:2022+A1

NORME EUROPÉENNE

EUROPÄISCHE NORM

March 2023

ICS 55.100

Supersedes EN 17665:2022

English Version

## Packaging - Test methods and requirements to demonstrate that plastic caps and lids remain attached to beverage containers

Emballage - Méthodes d'essai et exigences pour démontrer que les bouchons et les couvercles en plastique restent attachés aux récipients pour boissons

Verpackung - Prüfverfahren und Anforderungen, die nachweisen, dass Kunststoffverschlüsse von Getränkebehältern am Behälter angebunden bleiben

This European Standard was approved by CEN on 24 July 2022 and includes Amendment 1 approved by CEN on 14 March 2023.

CEN members are bound to comply with the CEN/CENELEC Internal Regulations which stipulate the conditions for giving this European Standard the status of a national standard without any alteration. Up-to-date lists and bibliographical references concerning such national standards may be obtained on application to the CEN-CENELEC Management Centre or to any CEN member.

This European Standard exists in three official versions (English, French, German). A version in any other language made by translation under the responsibility of a CEN member into its own language and notified to the CEN-CENELEC Management Centre has the same status as the official versions.

CEN members are the national standards bodies of Austria, Belgium, Bulgaria, Croatia, Cyprus, Czech Republic, Denmark, Estonia, Finland, France, Germany, Greece, Hungary, Iceland, Ireland, Italy, Latvia, Lithuania, Luxembourg, Malta, Netherlands, Norway, Poland, Portugal, Republic of North Macedonia, Romania, Serbia, Slovakia, Slovenia, Spain, Sweden, Switzerland, Türkiye and United Kingdom.



EUROPEAN COMMITTEE FOR STANDARDIZATION  
COMITÉ EUROPÉEN DE NORMALISATION  
EUROPÄISCHES KOMITEE FÜR NORMUNG

CEN-CENELEC Management Centre: Rue de la Science 23, B-1040 Brussels

<b>Contents</b>		Page
<b>European foreword</b> .....		3
<b>Introduction</b> .....		4
<b>1</b>	<b>Scope</b> .....	5
<b>2</b>	<b>Normative references</b> .....	5
<b>3</b>	<b>Terms and definitions</b> .....	5
<b>4</b>	<b>Requirements for the attachment feature</b> .....	6
<b>5</b>	<b>Test methods</b> .....	6
<b>6</b>	<b>Acceptance criteria for the attachment feature for attached caps and lids</b> .....	11
<b>7</b>	<b>Test report</b> .....	12
<b>Annex A (informative) Principle to quantify risks, including tolerable risks</b> .....		13
<b>Annex B (informative) Example for a safety risk assessment</b> .....		15
<b>Bibliography</b> .....		18

SIST EN 17665:2022+A1:2023

<https://standards.iteh.ai/catalog/standards/sist/13128bf6-02e1-4643-ab3e-c0461a9abb83/sist-en-17665-2022a1-2023>

## European foreword

This document (EN 17665:2022+A1:2023) has been prepared by Technical Committee CEN/TC 261 “Packaging”, the secretariat of which is held by AFNOR.

This European Standard shall be given the status of a national standard, either by publication of an identical text or by endorsement, at the latest by September 2023, and conflicting national standards shall be withdrawn at the latest by September 2023.

Attention is drawn to the possibility that some of the elements of this document may be the subject of patent rights. CEN shall not be held responsible for identifying any or all such patent rights.

This document includes Amendment 1 approved by CEN on 14 March 2023.

This document supersedes EN 17665:2022.

The start and finish of text introduced or altered by amendment is indicated in the text by tags A1 A1.

This document has been prepared under a Standardization Request given to CEN by the European Commission and the European Free Trade Association, A1 and supports essential requirements of EU Directive(s) / Regulation(s).

For relationship with EU Directive(s) / Regulation(s), see informative Annex ZA, which is an integral part of this document. A1

Any feedback and questions on this document should be directed to the users’ national standards body. A complete listing of these bodies can be found on the CEN website.

According to the CEN-CENELEC Internal Regulations, the national standards organizations of the following countries are bound to implement this European Standard: Austria, Belgium, Bulgaria, Croatia, Cyprus, Czech Republic, Denmark, Estonia, Finland, France, Germany, Greece, Hungary, Iceland, Ireland, Italy, Latvia, Lithuania, Luxembourg, Malta, Netherlands, Norway, Poland, Portugal, Republic of North Macedonia, Romania, Serbia, Slovakia, Slovenia, Spain, Sweden, Switzerland, Türkiye and the United Kingdom.

## Introduction

The Directive (EU) 2019/904 “on the reduction of the impact of certain plastic products on the environment” introduces the requirement that plastic caps and lids of single-use plastic beverage containers and composite beverage packaging up to 3 litres capacity shall remain attached to the container during the intended use stage.”

This document was developed with the principal objective of:

- Characterizing the attachment of the cap or lid to the container by a minimum resistance to a tensile force and the ability to remain attached to the container over the products intended use stage.
- Defining the test methods and performance criteria to ensure that the beverage container has met legal requirements.
- Ensuring that safety aspects of the attachment feature have been considered.

The intended use stage of the product infers that the attachment feature must resist normal handling of the cap or lid by the consumer to access the contents and, if necessary, reclose the container for subsequent further servings of the beverage. Intentional forced separation of the cap from the container will always be possible and is formally excluded from “intended use” as considered in this document.

The development of this document takes into account the necessity not to undermine the requirements of the Packaging and Packaging Waste Directive (94/62/EC) and its amendments in particular terms of:

- Prevention, limiting the packaging volume and weight to the minimum adequate amount to maintain the necessary functionality, by avoiding the use of excessive material.
- Recyclability and recycling capability.

In the course of the development of this document it was identified that the attachment of caps and lids to the container may interfere with established and efficient plastic bottle recycling equipment, particularly if attached caps or lids hang loose. This aspect is outside of the scope of this document, but it is recommended that the user takes into consideration best practice guidelines established by the stakeholders.

## 1 Scope

This document specifies the requirements and test methods to demonstrate that plastic caps and lids of single-use beverage containers with a capacity of up to three litres remain attached to the container during the product's intended use stage. This document also addresses the need to ensure the necessary strength, reliability and safety of beverage container closures, including those for carbonated drinks.

This document applies to the strength, reliability and safety impacted by the attachment features and does not apply to the overall closure system.

## 2 Normative references

The following documents are referred to in the text in such a way that some or all of their content constitutes requirements of this document. For dated references, only the edition cited applies. For undated references, the latest edition of the referenced document (including any amendments) applies.

ISO/IEC GUIDE 51:2014, *Safety aspects — Guidelines for their inclusion in standards*

## 3 Terms and definitions

For the purposes of this document, the terms and definitions given in ISO/IEC GUIDE 51:2014 and the following apply.

ISO and IEC maintain terminology databases for use in standardization at the following addresses:

- IEC Electropedia: available at <https://www.electropedia.org/>
- ISO Online browsing platform: available at <https://www.iso.org/obp>

### 3.1

#### **attachment feature**

physical link maintained between the cap or lid and the container during the intended use stage

### 3.2

#### **neck finish**

specific part of a container which forms the opening, manufactured with a defined geometry to accommodate the corresponding closure (cap, lid or other form of seal) and tamper-evidence feature if appropriate

### 3.3

#### **intended use stage**

opening in a normal way, consuming the contents, closing in a normal way, potentially multiple times, followed by proper disposal

Note 1: Intended use excludes intentional forced separation by the consumer for whatever reason.

Note 2: Proper disposal excludes littering.

### 3.4

#### **strength**

ability of the product to withstand forces that occur during the product's intended use stage

### 3.5

#### **reliability**

quality of the product to perform consistently well during the product's intended use stage

**EN 17665:2022+A1:2023 (E)****4 Requirements for the attachment feature****4.1 General**

The attachment feature of the caps and lids shall have the necessary strength, reliability and safety required for the intended use stage of the package.

**4.2 Strength of the attachment feature**

The attachment feature of caps and lids shall have the necessary strength to remain attached to the beverage container during the intended use stage.

The strength of the attachment feature shall be evaluated in accordance with the test method set out in 5.1 and the criteria specified in 6.1 Table 1.

**4.3 Reliability of the attachment feature**

The attachment feature of caps and lids shall have the necessary reliability to remain attached to the beverage container during the intended use stage.

The reliability of the attachment feature shall be evaluated in accordance with the test method set out in 5.2 and the criteria specified in 6.2 Table 2.

**4.4 Safety during the intended use stage**

The attachment feature of caps and lids shall have the necessary safety characteristics during the intended use stage.

A risk assessment of the attachment feature shall be carried out to ensure adequate product safety characteristics for the consumer.

The risk assessment can be integrated into normal product safety assessments.

A method for the risk assessment of the attachment feature is specified in 5.3.

**5 Test methods****5.1 Attachment feature – Resistance to a tensile force****5.1.1 General**

The test shall verify that the attachment feature of the cap or lid, is able to withstand a given linear tensile force without being detached from a beverage container.

**5.1.2 Equipment required**

The tensile testing device shall be capable of applying forces with an accuracy of  $\pm 1\%$  of the measured value. The tensile testing device shall be equipped with a clamp, forceps, hook or other suitable gripping system capable of holding the component firmly without deformation when no force is applied.

**5.1.3 Sample size**

10 separate samples shall be used for each subtest (subtest 1 and subtest 2), i.e. 20 samples in total.

The tests shall be performed on separate caps or lids, not repeated on the same item.

The samples shall be visually inspected before starting the tests in order to discard any defective samples, which will need to be replaced with acceptable samples.



#### 5.1.4 Sample preparation

The cap or lid under test shall be applied to the neck finish for which it is designed and in accordance with the cap or lid manufacturer's specification.

The temperature of the samples to be tested shall be stabilized for 24 h at  $(23 \pm 2)$  °C. Testing shall be carried out at this temperature.

#### 5.1.5 Test method

This test consists of two subtests to assess the resistance of the attachment feature to tensile forces.

- 1) The first test (subtest 1) shall be in the direction of the neck finish main axis ( $180^\circ$ ) as shown in Figure 1.

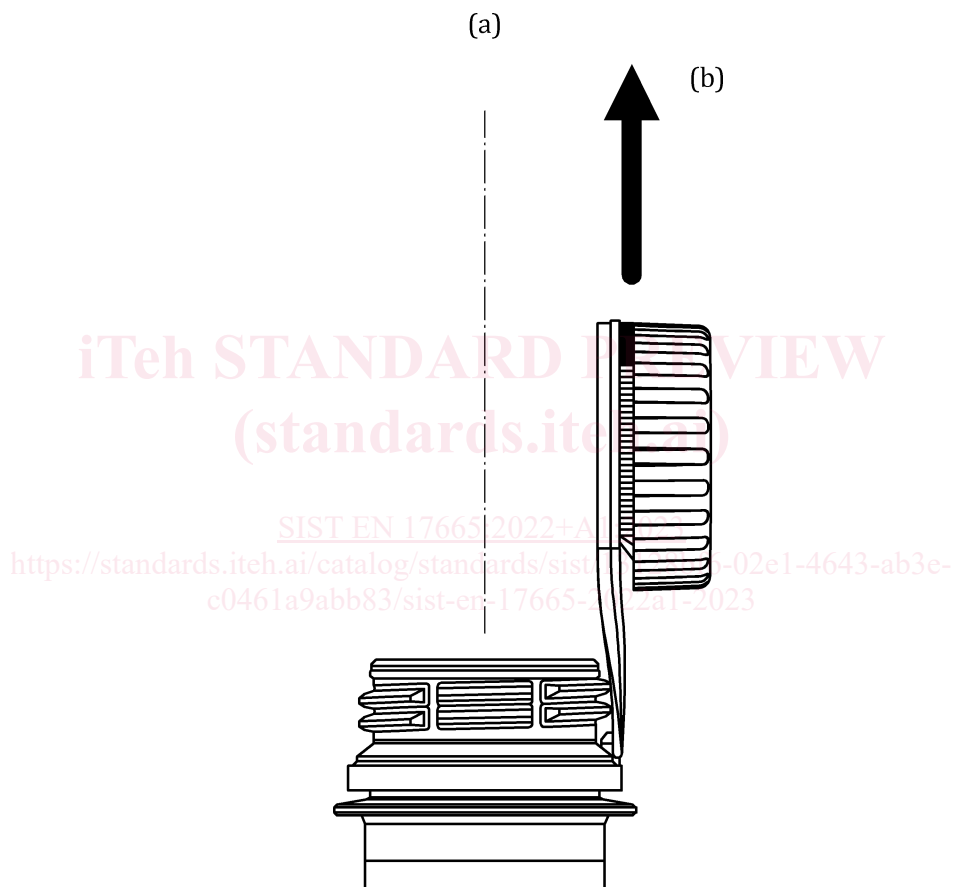

#### Key

- a neck finish main axis
- b direction of traction force

**Figure 1 — Illustrative example of test in the direction of the finish main axis ( $180^\circ$ )**

## EN 17665:2022+A1:2023 (E)

- 2) The second test (subtest 2) shall be in a perpendicular direction to the neck finish main axis (90°) as shown in Figure 2.

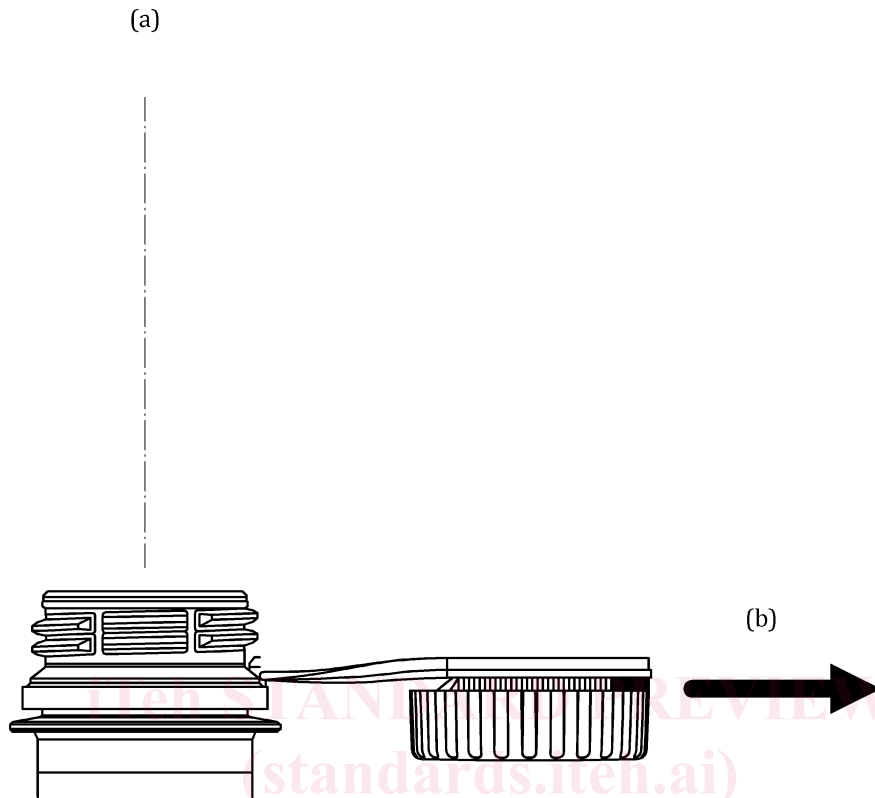
**Key**

- a neck finish main axis  
b direction of traction force

**Figure 2 — Illustrative example of test in a perpendicular direction to the finish main axis (90°)**

In cases where the neck finish forms an integral part of the container, preforms may be used instead of containers. For neck finishes which are not an integral part of the container separate neck finishes may be used, held secure in an appropriate fixture for testing.

### 5.1.6 Subtest 1 in the direction of the neck finish main axis (180°)

The subtest shall be conducted as follows:

- a) Place the container with the applied cap or lid into the fixture.
- b) Open the cap or lid completely.
- c) Attach the opened cap or lid to the gripping system (clamp, forceps, hook, etc.).
- d) Apply a tensile force in the direction of the neck finish main axis at a test speed of 200 mm/min  $\pm$  20 mm/min up to the value specified in Table 1 in 6.1.
- e) Record if the cap or lid detaches or remains attached.
- f) Repeat steps a) through e) until all 10 samples of the subtest have been tested.
- g) Proceed with subtest 2 of the test method.

### 5.1.7 Subtest 2 in a perpendicular direction to the neck finish main axis (90°)

The subtest shall be conducted as follows:

- a) Place the container with the applied cap or lid into the fixture.
- b) Open the cap or lid completely.
- c) Attach the opened cap or lid to the gripping system (clamp, forceps, hook, etc.).
- d) Apply a tensile force in a direction perpendicular to that of the neck finish main axis at a test speed of 200 mm/min  $\pm$  20 mm/min up to the value specified in Table 1 in 6.1.
- e) Record if the cap or lid detaches or remains attached.
- f) Repeat steps a) through e) until all 10 samples of the subtest have been tested.
- g) TEST COMPLETE.

## 5.2 Attachment feature – Reliability during the intended use stage

### 5.2.1 General

The test shall determine the reliability of the attachment feature of the cap or lid to the beverage container to resist multiple opening and closing cycles representing the product's intended use stage.

The forces (direction and magnitude) applied to the cap or lid and the attachment feature shall be limited to those necessary to open and close the beverage container.

### 5.2.2 Equipment required

Fixture to hold the beverage container (optional).

### 5.2.3 Sample size

15 separate samples of the beverage container to be tested shall be used.

The samples shall be visually inspected before starting the tests in order to discard any defective samples, which will need to be replaced with acceptable samples.

### 5.2.4 Sample preparation

The cap or lid under test shall be applied to the neck finish for which it is designed and in accordance with the cap or lid manufacturer's specification. Before testing, the temperature of the products shall be stabilized for 24 h at  $(23 \pm 2)$  °C.

Testing shall be carried out at this temperature.