

FINAL
DRAFT

INTERNATIONAL
STANDARD

ISO/FDIS
29463-5

ISO/TC 142

Secretariat: UNI

Voting begins on:
2021-12-14

Voting terminates on:
2022-02-08

High-efficiency filters and filter media for removing particles in air —

Part 5: Test method for filter elements

*Filtres à haut rendement et filtres pour l'élimination des particules
dans l'air —*

iTeh STANDARD PREVIEW
Partie 5: Méthode d'essai des éléments filtrants
(standards.iteh.ai)

[ISO/FDIS 29463-5](https://standards.iteh.ai/catalog/standards/sist/4a20c9f6-873a-46e4-9c12-aa60640482ac/iso-fdis-29463-5)

<https://standards.iteh.ai/catalog/standards/sist/4a20c9f6-873a-46e4-9c12-aa60640482ac/iso-fdis-29463-5>

ISO/CEN PARALLEL PROCESSING

RECIPIENTS OF THIS DRAFT ARE INVITED TO SUBMIT, WITH THEIR COMMENTS, NOTIFICATION OF ANY RELEVANT PATENT RIGHTS OF WHICH THEY ARE AWARE AND TO PROVIDE SUPPORTING DOCUMENTATION.

IN ADDITION TO THEIR EVALUATION AS BEING ACCEPTABLE FOR INDUSTRIAL, TECHNOLOGICAL, COMMERCIAL AND USER PURPOSES, DRAFT INTERNATIONAL STANDARDS MAY ON OCCASION HAVE TO BE CONSIDERED IN THE LIGHT OF THEIR POTENTIAL TO BECOME STANDARDS TO WHICH REFERENCE MAY BE MADE IN NATIONAL REGULATIONS.



Reference number
ISO/FDIS 29463-5:2021(E)

© ISO 2021

iTeh STANDARD PREVIEW
(standards.iteh.ai)

ISO/FDIS 29463-5

<https://standards.iteh.ai/catalog/standards/sist/4a20c9f6-873a-46e4-9cf2-aa60640482ac/iso-fdis-29463-5>



COPYRIGHT PROTECTED DOCUMENT

© ISO 2021

All rights reserved. Unless otherwise specified, or required in the context of its implementation, no part of this publication may be reproduced or utilized otherwise in any form or by any means, electronic or mechanical, including photocopying, or posting on the internet or an intranet, without prior written permission. Permission can be requested from either ISO at the address below or ISO's member body in the country of the requester.

ISO copyright office
CP 401 • Ch. de Blandonnet 8
CH-1214 Vernier, Geneva
Phone: +41 22 749 01 11
Email: copyright@iso.org
Website: www.iso.org

Published in Switzerland

Contents

Page

Foreword.....	v
Introduction.....	vi
1 Scope.....	1
2 Normative references.....	1
3 Terms, definitions, symbols and abbreviated terms.....	1
3.1 Terms and definitions.....	1
3.2 Symbols and abbreviated terms.....	2
4 Efficiency test methods.....	3
4.1 Reference efficiency test method.....	3
4.2 Alternate efficiency test method for groups H and U filters.....	3
4.3 Statistical efficiency test method for low efficiency filters — Group E filters.....	3
5 Test filter.....	4
6 Test apparatus.....	4
6.1 General.....	4
6.2 Test duct.....	5
6.2.1 Test air conditioning.....	5
6.2.2 Adjustment of the volume flow rate.....	5
6.2.3 Measurement of the volume flow rate.....	5
6.2.4 Aerosol mixing section.....	5
6.2.5 Test filter mounting assembly.....	6
6.2.6 Measuring points for the pressure drop.....	6
6.2.7 Sampling.....	6
6.3 Aerosol generation and measuring instruments.....	6
6.3.1 General.....	6
6.3.2 Apparatus for testing with a mono-disperse test aerosol.....	7
6.3.3 Apparatus for testing with a poly-disperse test aerosol.....	7
7 Conditions of the test air.....	11
8 Test procedure.....	12
8.1 Preparatory checks.....	12
8.2 Starting up the aerosol generator.....	12
8.3 Preparation of the test filter.....	12
8.3.1 Installation of the test filter.....	12
8.3.2 Flushing the test filter.....	12
8.4 Testing.....	12
8.4.1 Measuring the pressure drop.....	12
8.4.2 Testing with a mono-disperse test aerosol.....	13
8.4.3 Testing with a poly-disperse test aerosol.....	13
8.4.4 Testing filters with charged media.....	13
9 Evaluation.....	13
10 Test report.....	15
11 Maintenance and inspection of the test apparatus.....	16
Annex A (normative) Alternate efficiency test method from scan testing.....	17
Annex B (informative) Testing and classification method for filters with MPPS ≤ 0,1 µm (e.g. membrane medium filters).....	18
Annex C (normative) Method for testing and classification of filters using media with charged fibres.....	21
Annex D (informative) Traditional efficiency test methods for HEPA and ULPA filters.....	27

iTeh STANDARD PREVIEW
(standards.iteh.ai)

ISO/FDIS 29463-5

<https://standards.iteh.ai/catalog/standards/sist/4a20c9f6-873a-46e4-9cf2-aa60640482ac/iso-fdis-29463-5>

Foreword

ISO (the International Organization for Standardization) is a worldwide federation of national standards bodies (ISO member bodies). The work of preparing International Standards is normally carried out through ISO technical committees. Each member body interested in a subject for which a technical committee has been established has the right to be represented on that committee. International organizations, governmental and non-governmental, in liaison with ISO, also take part in the work. ISO collaborates closely with the International Electrotechnical Commission (IEC) on all matters of electrotechnical standardization.

The procedures used to develop this document and those intended for its further maintenance are described in the ISO/IEC Directives, Part 1. In particular, the different approval criteria needed for the different types of ISO documents should be noted. This document was drafted in accordance with the editorial rules of the ISO/IEC Directives, Part 2 (see www.iso.org/directives).

Attention is drawn to the possibility that some of the elements of this document may be the subject of patent rights. ISO shall not be held responsible for identifying any or all such patent rights. Details of any patent rights identified during the development of the document will be in the Introduction and/or on the ISO list of patent declarations received (see www.iso.org/patents).

Any trade name used in this document is information given for the convenience of users and does not constitute an endorsement.

For an explanation of the voluntary nature of standards, the meaning of ISO specific terms and expressions related to conformity assessment, as well as information about ISO's adherence to the World Trade Organization (WTO) principles in the Technical Barriers to Trade (TBT), see www.iso.org/iso/foreword.html (standards.iteh.ai)

This document was prepared by Technical Committee ISO/TC 142, *Cleaning equipment for air and other gases*, in collaboration with the European Committee for Standardization (CEN) Technical Committee CEN/TC 195, *Air filters for general air cleaning*, in accordance with the Agreement on technical cooperation between ISO and CEN (Vienna Agreement).

This second edition cancels and replaces the first edition (ISO 29463-5:2011), which has been technically revised.

The main changes compared to the previous edition are as follows:

- normative references are updated;
- [Annex C](#) is revised.

A list of all parts in the ISO 29463 series can be found on the ISO website.

Any feedback or questions on this document should be directed to the user's national standards body. A complete listing of these bodies can be found at www.iso.org/members.html.

Introduction

The ISO 29463 series is derived from the EN 1822 series with extensive changes to meet the requests from non-European participating members (P-members). It contains requirements, fundamental principles of testing and the marking for high-efficiency particulate air filters with efficiencies from 95 % to 99,999 995 % that can be used for classifying filters in general or for specific use by agreement between users and suppliers.

The ISO 29463 series establishes a procedure for the determination of the efficiency of all filters on the basis of a particle counting method using a liquid (or alternatively a solid) test aerosol, and allows a standardized classification of these filters in terms of their efficiency, both local and overall efficiency, which actually covers most requirements of different applications. The difference between the ISO 29463 series and other national standards lies in the technique used for the determination of the overall efficiency. Instead of mass relationships or total concentrations, this technique is based on particle counting at the MPPS, which is, for micro-glass filter mediums, usually in the range of 0,12 µm to 0,25 µm. This method also allows testing ultra-low-penetration air filters, which was not possible with the previous test methods because of their inadequate sensitivity. For membrane filter media, separate rules apply and are described in [Annex B](#). Although no equivalent test procedures for testing filters with charged media is prescribed, a method for dealing with these types of filters is described in [Annex C](#). Specific requirements for testing method, frequency, and reporting requirements can be modified by agreement between users and suppliers. For lower-efficiency filters (group H, as described in [4.2](#)), alternate leak test methods are described in ISO 29463-4:2011, Annex A.

There are differences between the ISO 29463 series and other normative practices common in several countries. For example, many of these rely on total aerosol concentrations rather than individual particles. For information, a brief summary of these methods and their reference standards are provided in [Annex D](#).

[ISO/FDIS 29463-5](#)

<https://standards.iteh.ai/catalog/standards/sist/4a20c9f6-873a-46e4-9cf2-aa60640482ac/iso-fdis-29463-5>

High-efficiency filters and filter media for removing particles in air —

Part 5: Test method for filter elements

1 Scope

This document specifies the test methods for determining the efficiency of filters at their most penetrating particle size (MPPS). It also gives guidelines for the testing and classification for filters with an MPPS of less than 0,1 μm ([Annex B](#)) and filters using media with (charged) synthetic fibres ([Annex C](#)). It is intended for use in conjunction with ISO 29463-1, ISO 29463-2, ISO 29463-3 and ISO 29463-4.

2 Normative references

The following documents are referred to in the text in such a way that some or all of their content constitutes requirements of this document. For dated references, only the edition cited applies. For undated references, the latest edition of the referenced document (including any amendments) applies.

ISO 5167-1, *Measurement of fluid flow by means of pressure differential devices inserted in circular cross-section conduits running full — Part 1: General principles and requirements*

ISO 16890-4, *Air filters for general ventilation — Part 4: Conditioning method to determine the minimum fractional test efficiency*

ISO 21501-4, *Determination of particle size distribution — Single particle light interaction methods — Part 4: Light scattering airborne particle counter for clean spaces*

ISO 29463-1:2017, *High efficiency filters and filter media for removing particles from air — Part 1: Classification, performance, testing and marking*

ISO 29463-2:2011, *High-efficiency filters and filter media for removing particles in air — Part 2: Aerosol production, measuring equipment and particle-counting statistics*

ISO 29463-3, *High-efficiency filters and filter media for removing particles in air — Part 3: Testing flat sheet filter media*

ISO 29463-4:2011, *High-efficiency filters and filter media for removing particles in air — Part 4: Test method for determining leakage of filter elements-Scan method*

3 Terms, definitions, symbols and abbreviated terms

3.1 Terms and definitions

For the purposes of this document, the terms and definitions given in ISO 29463-1, ISO 29463-2, ISO 29463-3, ISO 29463-4, and the following apply.

ISO and IEC maintain terminology databases for use in standardization at the following addresses:

- ISO Online browsing platform: available at <https://www.iso.org/obp>
- IEC Electropedia: available at <https://www.electropedia.org/>

3.1.1

sampling duration

time during which the particles in the sampling volume flow are counted (upstream or downstream)

[SOURCE: ISO 29464:2017, 3.2.153]

3.1.2

particle counting and sizing method

particle counting method which allows both the determination of the number of particles and also the classification of the particles according to size

EXAMPLE By using an optical particle counter (OPC).

[SOURCE: ISO 29464:2017, 3.2.123]

3.2 Symbols and abbreviated terms

C channel for particle counters

c_N number concentration

d_p particle diameter, μm

E efficiency

k dilution factor

N particle counts

P penetration, %

p absolute pressure, Pa

T temperature, K

t sampling duration, s

\dot{V} volume flow rate, cm^3/s

Δp differential pressure, Pa

φ relative humidity, %

CPC condensation particle counter

DEHS di(2-ethylhexyl) sebacate

DMPS differential mobility particle sizer

DOP dioctyl phthalate

ePTFE expanded polytetrafluoroethylene

IPA isopropyl alcohol (isopropanol)

MPPS most penetrating particle size

OPC optical particle counter

iTeh STANDARD PREVIEW
(standards.iteh.ai)

[ISO/FDIS 29463-5](https://standards.iteh.ai/catalog/standards/sist/4a20c9f6-873a-46e4-9cf2-aa60640482ac/iso-fdis-29463-5)

<https://standards.iteh.ai/catalog/standards/sist/4a20c9f6-873a-46e4-9cf2-aa60640482ac/iso-fdis-29463-5>

4 Efficiency test methods

4.1 Reference efficiency test method

In order to determine the efficiency of the test filter, the test filter is fixed in the filter mounting assembly and subjected to a test air volume flow corresponding to the nominal volume flow rate.

After the pressure drop at the nominal volumetric flow rate is measured, the test aerosol produced by the aerosol generator is mixed with the prepared test air along a mixing section, so that it is spread homogeneously over the cross-section of the duct.

The efficiency is always determined for the MPPS; see ISO 29463-3. The size distribution of the aerosol particles can optionally be measured using a particle size analysis system, for example, a DMPS.

The testing can be carried out using either a mono-disperse or poly-disperse test aerosol. When testing with (quasi-) mono-disperse aerosol, the total particle count method may be used with a CPC or an OPC, e.g. a laser particle counter. It shall be ensured that the number median particle diameter corresponds to the MPPS, i.e. the particle diameter at which the filter medium has its minimum efficiency.

When using a poly-disperse aerosol, the particle counting and sizing method, e.g. an OPC or DMPS, shall be used, which, in addition to counting the particles, is also able to determine their size distribution. It shall be ensured that the count median diameter, D_M , of the test aerosol lies in the range given by [Formula \(1\)](#):

$$\frac{S_{MPPS}}{1,5} < D_M < 1,5 \times S_{MPPS} \quad (1)$$

where S_{MPPS} is the most penetrating particle size.

In order to determine the overall efficiency, representative partial flows are extracted on the upstream and downstream sides of the filter element and directed to the attached particle counter via a fixed sampling probe to measure the number of particles. It is necessary to have a mixing section behind the test filter to mix the aerosol homogeneously with the test air over the duct cross-section (see [6.2.4](#)). When testing filters with large face dimensions, achieving adequate aerosol mixing may not be possible. In these cases, the test method with moving probe described in [Annex A](#) shall be used.

4.2 Alternate efficiency test method for groups H and U filters

The standard efficiency test method, as described in [4.1](#), uses downstream mixing and a fixed downstream probe. However, an alternate efficiency test method using scan test equipment with moving probe(s) is provided and described in [Annex A](#).

4.3 Statistical efficiency test method for low efficiency filters — Group E filters

For filters of group E, the overall efficiency shall be determined by one of the statistical test procedures described in this subclause, and it is not necessary to carry out the test for each single filter element (as is mandatory for filters of groups H and U). The overall efficiency of group E filters shall be determined by averaging the results of the statistical leak test as described in this subclause.

A record of the filter data in the form of a type test certificate or alternatively a factory test certificate is required. However, the supplier shall be able to provide documentary evidence to verify the published filter data upon request. This can be done by either:

- a) maintaining a certified quality management system (e.g. ISO 9000), which requires the application of statistically based methods for testing and documenting efficiency for group E filters in accordance with this document; or
- b) using accepted statistical methods to test all of production lots of filters.

The skip lot procedure as described in ISO 2859-1 or any equivalent alternative method may be used.

The skip lot procedure as described in ISO 2859-1 implies that at the beginning, the test frequency is high and is, in the course of further testing, reduced as the production experience grows and that the products produced conform to the target. For example, for the first eight production lots, 100 % of the produced filters are tested. If all the tests are positive, the frequency is reduced to half for the next eight production lots. If all the tests are positive again, the number is reduced by half again, and so on until it is necessary to test only one out of eight lots (e.g. the minimum test frequency). Each time one of the tested filters fails, the test frequency is doubled again. In any case, the number of samples per lot tested shall be greater than three filters.

5 Test filter

The filter element being tested shall show no signs of damage or any other irregularities. The filter element shall be handled carefully and shall be clearly and permanently marked with the following details:

- designation of the filter element;
- upstream side of the filter element.

The temperature of the test filter during the testing shall correspond with that of the test air.

6 Test apparatus

6.1 General

A flow sheet showing the arrangement of apparatus comprising a test rig is given in ISO 29463-1:2017, Figure 4. An outline diagram of a test rig is given in [Figure 1](#).

The fundamentals of aerosol generation and neutralization with details of suitable types of equipment as well as detailed descriptions of the measuring instruments required for the testing are given in ISO 29463-2.

iTeh STANDARD PREVIEW

(standards.itih.ai)

ISO/FDIS 29463-5

<https://standards.itih.ai/catalog/standards/sist/4a20c9f6-873a-46e4-9cd-aa60640482ac/iso-fdis-29463-5>

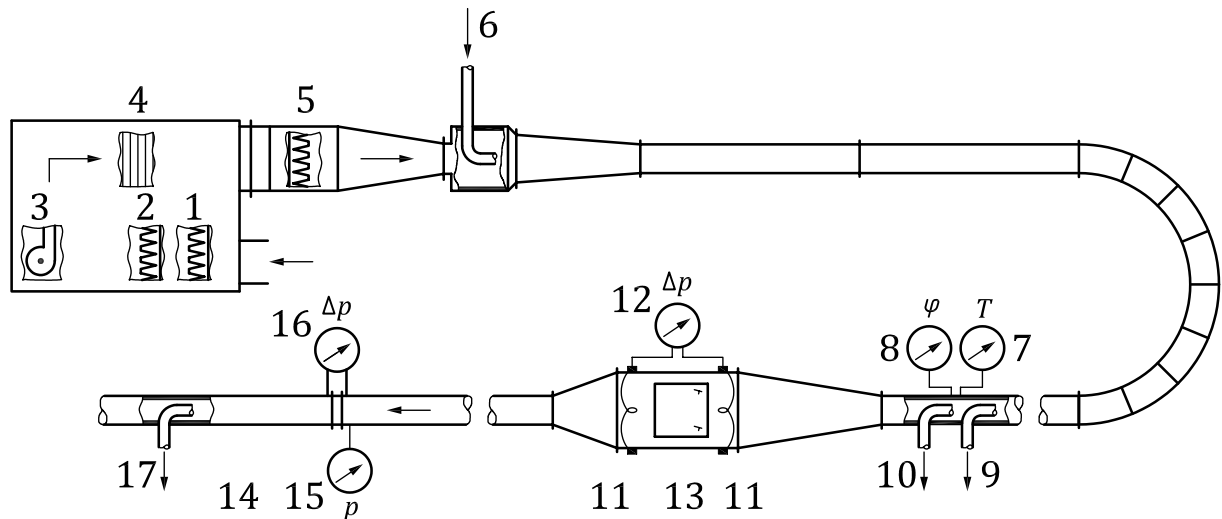

Key

1	coarse dust filter	10	sampler, upstream
2	fine dust filter	11	ring pipe for differential pressure measurement
3	fan	12	manometer (Δp)
4	air heating	13	test filter mounting assembly
5	high-efficiency air filter	14	measuring damper (see ISO 5167-1)
6	aerosol inlet to the test duct	15	measurement of absolute pressure (p)
7	temperature measurement (T)	16	manometer measuring differential pressure (Δp)
8	hygrometer (φ)	17	sampler, downstream
9	sampler, particle size analysis		

ISO/FDIS 29463-5

<https://standards.iteh.ai/catalog/standards/sist/4a20c9f6-873a-46e4-9cf2-4200482ac6a0/iso-29463-5>

Figure 1 — Example of a test rig

6.2 Test duct

6.2.1 Test air conditioning

The test air conditioning equipment shall include equipment required to control the condition of the test air so that it can be brought in conformity with the requirement of [Clause 7](#).

6.2.2 Adjustment of the volume flow rate

Filters shall always be tested at their nominal air flow rate. It shall be possible to adjust the volume flow rate by means of a suitable provision (e.g. by changing the speed of the fan, or with dampers) to a value $\pm 5\%$ of the nominal flow rate, which shall then remain constant within $\pm 2\%$ throughout each test.

6.2.3 Measurement of the volume flow rate

The volume flow rate shall be measured using a standardized or calibrated method (e.g. measurement of the differential pressure using standardized damper equipment, such as orifice plates, or nozzles, Venturi tubes in accordance with ISO 5167-1).

The limit error of measurement shall not exceed 5 % of the measured value.

6.2.4 Aerosol mixing section

The aerosol input and the mixing section (see [Figure 1](#) for an example) shall be so constructed that the aerosol concentration measured at individual points of the duct cross-section, directly in front of the

test filter, do not deviate by more than 10 % from the mean value of at least nine measuring points over the channel cross-section.

6.2.5 Test filter mounting assembly

The test filter mounting assembly shall ensure that the test filter can be sealed and subjected to flow in accordance with requirements.

It shall not obstruct any part of the filter cross-sectional area.

6.2.6 Measuring points for the pressure drop

The measuring points for pressure drop shall be so arranged that the mean value of the static pressure in the flow upstream and downstream of the filter can be measured. The planes of the pressure measurements upstream and downstream shall be positioned in regions of an even flow with a uniform flow profile.

In rectangular or square test ducts, smooth holes with a diameter of 1 mm to 2 mm for the pressure measurements shall be bored in the middle of the channel walls, normal to the direction of flow. The four holes shall be interconnected with a circular pipe.

6.2.7 Sampling

In order to determine the efficiency, sampled volumes of air are extracted from the test volume flow by sampling probes and led to the particle counters. The diameter of the probes shall be chosen so that isokinetic conditions are maintained in the in the probe at the given volume flow rate in the duct. In this way, sampling errors can be neglected due to the small size of the particles in the test aerosol. The connections to the particle counter shall be as short as possible. Samples on the upstream side are taken by a fixed sampling probe in front of the test filter. The sampling shall be representative, on the basis that the aerosol concentration measured from the sample does not deviate by more than ± 10 % from the mean value determined in accordance with 6.2.4.

A fixed sampling probe is also installed downstream, preceded by a mixing section that ensures a representative measurement of the downstream aerosol concentration. This is taken to be the case when, in event of an artificially made big leak in the test filter, the aerosol concentration measured downstream the filter does not at any point deviate by more than ± 10 % from the mean value of at least nine measuring points over the duct cross-section. It is necessary, however, to verify beforehand that the artificially made leak is big enough to increase the filter penetration by at least a factor of five relative to the penetration of the non-leaking filter.

The mean aerosol concentrations determined at the upstream and downstream sampling points without the filter in position shall not differ from each other by more than 5 %.

6.3 Aerosol generation and measuring instruments

6.3.1 General

The operating parameters of the aerosol generator shall be adjusted to produce a test aerosol whose number median diameter is in the range of the MPPS for the sheet filter medium.

The median size of the mono-disperse test aerosol shall not deviate from the MPPS by more than ± 10 %. A deviation of ± 50 % is allowed when using a poly-disperse aerosol.

The particle output of the aerosol generator shall be adjusted according to the test volume flow rate and the filter efficiency, so that the counting rates on the upstream and downstream sides lie under the coincidence limits of the counter (the maximum coincidence error shall be of 10 % in accordance with ISO 21501-4), and significantly above the zero-count rate of the instruments.