**Lasers and laser-related equipment —
Test methods for laser beam
widths, divergence angles and beam
propagation ratios —**

Part 1:

**Stigmatic and simple astigmatic
beams**

(standards.iteh.ai)

*Lasers et équipements associés aux lasers — Méthodes d'essai des
largeurs du faisceau, angles de divergence et facteurs de limite de
diffraction —*

<https://standards.iteh.ai/standards/sist/ad90aba7-7773-44a0-a18a-43e17e51d35f/iso-11146-1-2021>

Partie 1: Faisceaux stigmatiques et astigmatiques simples



iTeh STANDARD PREVIEW
(standards.iteh.ai)

ISO 11146-1:2021

<https://standards.iteh.ai/catalog/standards/sist/ad90aba7-7773-44a0-a18a-42a17a51d35f/iso-11146-1-2021>



COPYRIGHT PROTECTED DOCUMENT

© ISO 2021

All rights reserved. Unless otherwise specified, or required in the context of its implementation, no part of this publication may be reproduced or utilized otherwise in any form or by any means, electronic or mechanical, including photocopying, or posting on the internet or an intranet, without prior written permission. Permission can be requested from either ISO at the address below or ISO's member body in the country of the requester.

ISO copyright office
CP 401 • Ch. de Blandonnet 8
CH-1214 Vernier, Geneva
Phone: +41 22 749 01 11
Email: copyright@iso.org
Website: www.iso.org

Published in Switzerland

Contents

	Page
Foreword.....	iv
Introduction.....	v
1 Scope.....	1
2 Normative references.....	1
3 Terms and definitions.....	1
4 Coordinate systems.....	7
5 Test principles.....	7
5.1 Applicability.....	7
5.2 Beam widths and beam diameter.....	7
5.3 Beam divergence angles.....	8
5.4 Beam propagation ratios.....	8
5.5 Combined measurement of beam waist locations, beam widths, beam divergence angles and beam propagation ratios.....	8
6 Measurement arrangement and test equipment.....	8
6.1 General.....	8
6.2 Preparation.....	8
6.3 Control of environment.....	9
6.4 Detector system.....	9
6.5 Beam-forming optics and optical attenuators.....	9
6.6 Focusing system.....	10
7 Beam widths and beam diameter measurement.....	10
7.1 Test procedure.....	10
7.2 Evaluation.....	10
8 Measurement of divergence angles.....	12
8.1 Test procedure.....	12
8.2 Evaluation.....	12
9 Combined determination of beam waist locations, beam widths, divergence angles and beam propagation ratios.....	12
10 Test report.....	14
Bibliography.....	17

Foreword

ISO (the International Organization for Standardization) is a worldwide federation of national standards bodies (ISO member bodies). The work of preparing International Standards is normally carried out through ISO technical committees. Each member body interested in a subject for which a technical committee has been established has the right to be represented on that committee. International organizations, governmental and non-governmental, in liaison with ISO, also take part in the work. ISO collaborates closely with the International Electrotechnical Commission (IEC) on all matters of electrotechnical standardization.

The procedures used to develop this document and those intended for its further maintenance are described in the ISO/IEC Directives, Part 1. In particular, the different approval criteria needed for the different types of ISO documents should be noted. This document was drafted in accordance with the editorial rules of the ISO/IEC Directives, Part 2 (see www.iso.org/directives).

Attention is drawn to the possibility that some of the elements of this document may be the subject of patent rights. ISO shall not be held responsible for identifying any or all such patent rights. Details of any patent rights identified during the development of the document will be in the Introduction and/or on the ISO list of patent declarations received (see www.iso.org/patents).

Any trade name used in this document is information given for the convenience of users and does not constitute an endorsement.

For an explanation of the voluntary nature of standards, the meaning of ISO specific terms and expressions related to conformity assessment, as well as information about ISO's adherence to the World Trade Organization (WTO) principles in the Technical Barriers to Trade (TBT), see www.iso.org/iso/foreword.html.

This document was prepared by Technical Committee ISO/TC 172, *Optics and photonics*, Subcommittee SC 9, *Laser and electro-optical systems*, in collaboration with the European Committee for Standardization (CEN) Technical Committee CEN/TC 123, *Lasers and photonics*, in accordance with the Agreement on technical cooperation between ISO and CEN (Vienna Agreement).

This second edition cancels and replaces the first edition (ISO 11146-1:2005), which has been technically revised. The main changes compared to the previous edition are as follows:

- The terms and definitions were harmonized with the new edition of ISO 11145.
- The "principal axes" were defined more thoroughly and named as x' and y' . Quantities related to the principal axes coordinate system refer to this definition and use x' and y' in their indices.
- The requirements for the integration range for the determination of the second order moments have been relaxed.

A list of all parts in the ISO 11146 series can be found on the ISO website.

Any feedback or questions on this document should be directed to the user's national standards body. A complete listing of these bodies can be found at www.iso.org/members.html.

Introduction

The propagation properties of every laser beam can be characterized within the method of second order moments by ten independent parameters (see ISO/TR 11146-3). However, due to their higher symmetry most laser beams of practical interest need fewer parameters for a complete description. Most lasers of practical use emit beams which are stigmatic or simple astigmatic because of their resonator design.

This document describes the measurement methods for stigmatic and simple astigmatic beams while ISO 11146-2 deals with the measurement procedures for general astigmatic beams. For beams of unknown type the methods of ISO 11146-2 are applicable. Beam characterization based on the method of second order moments as described in both parts is only valid within the paraxial approximation.

The theoretical description of beam characterization and propagation as well as the classification of laser beams is given in ISO/TR 11146-3, which is a Technical Report and describes the procedures for background subtraction and offset correction.

In this document, the second order moments of the power (energy) density distribution are used for the determination of beam widths. However, there may be problems experienced in the direct measurement of these quantities in the beams from some laser sources. In this case, other indirect methods of the measurement of the second order moments may be used as long as comparable results are achievable.

In ISO/TR 11146-3, three alternative methods for beam width measurement and their correlation with the method used in this document are described. These methods are:

- variable aperture method;
- moving knife-edge method;
- moving slit method.

 (standards.iteh.ai)

ISO 11146-1:2021

<https://standards.iteh.ai/catalog/standards/sist/ad90aba7-7773-44a0-a18a-42a17a51d35f/iso-11146-1-2021>

iTeh STANDARD PREVIEW
(standards.iteh.ai)

ISO 11146-1:2021

<https://standards.iteh.ai/catalog/standards/sist/ad90aba7-7773-44a0-a18a-42a17a51d35f/iso-11146-1-2021>

Lasers and laser-related equipment — Test methods for laser beam widths, divergence angles and beam propagation ratios —

Part 1: Stigmatic and simple astigmatic beams

1 Scope

This document specifies methods for measuring beam widths (diameter), divergence angles and beam propagation ratios of laser beams. This document is only applicable for stigmatic and simple astigmatic beams. If the type of the beam is unknown, and for general astigmatic beams, ISO 11146-2 is applicable.

2 Normative references

The following documents are referred to in the text in such a way that some or all of their content constitutes requirements of this document. For dated references, only the edition cited applies. For undated references, the latest edition of the referenced document (including any amendments) applies

ISO 11145, *Optics and photonics — (Lasers and laser-related equipment) — Vocabulary and symbols*

ISO 11146-2, *Lasers and laser-related equipment — Test methods for laser beam widths, divergence angles and beam propagation ratios — Part 2: General astigmatic beams*

ISO 13694, *Optics and photonics — Lasers and laser-related equipment — Test methods for laser beam power (energy) density distribution*

EN 61040:1992, *Power and energy measuring detectors, instruments and equipment for laser radiation*

3 Terms and definitions

For the purposes of this document, the terms and definitions given in ISO 11145, ISO 13694, EN 61040 and the following apply.

ISO and IEC maintain terminological databases for use in standardization at the following addresses:

- ISO Online browsing platform: available at <https://www.iso.org/obp>
- IEC Electropedia: available at <https://www.electropedia.org/>

NOTE The x-, y- and z-axes in these definitions refer to the laboratory system as described in [Clause 4](#). Here and throughout this document the term “power density distribution $E(x,y,z)$ ” refers to continuous wave sources. It might be replaced by “energy density distribution, $H(x,y,z)$ ” in case of pulsed sources.

3.1 first order moments of a power density distribution

\bar{x}, \bar{y}
centroid coordinates of the power density distribution of a cross section of a beam given as

$$\bar{x}(z) = \frac{\int_{-\infty}^{\infty} \int_{-\infty}^{\infty} E(x, y, z) x \, dx \, dy}{\int_{-\infty}^{\infty} \int_{-\infty}^{\infty} E(x, y, z) \, dx \, dy} \tag{1}$$

and

$$\bar{y}(z) = \frac{\int_{-\infty}^{\infty} \int_{-\infty}^{\infty} E(x, y, z) y \, dx \, dy}{\int_{-\infty}^{\infty} \int_{-\infty}^{\infty} E(x, y, z) \, dx \, dy} \tag{2}$$

Note 1 to entry: The first order moments are used for the definition of beam centroid in ISO 11145.

Note 2 to entry: For practical application, the infinite integration limits are reduced in a specific manner as given in [Clause 7](#). The limitation of the integration area here differs from the integration area given in ISO 11145.

3.2 second order moments of a power density distribution

$\sigma_x^2, \sigma_y^2, \sigma_{xy}^2$
normalized weighted integrals over the power density distribution, given as:

$$\sigma_x^2(z) = \langle x^2 \rangle = \frac{\int_{-\infty}^{\infty} \int_{-\infty}^{\infty} E(x, y, z) [x - \bar{x}(z)]^2 \, dx \, dy}{\int_{-\infty}^{\infty} \int_{-\infty}^{\infty} E(x, y, z) \, dx \, dy} \tag{3}$$

and

$$\sigma_y^2(z) = \langle y^2 \rangle = \frac{\int_{-\infty}^{\infty} \int_{-\infty}^{\infty} E(x, y, z) [y - \bar{y}(z)]^2 \, dx \, dy}{\int_{-\infty}^{\infty} \int_{-\infty}^{\infty} E(x, y, z) \, dx \, dy} \tag{4}$$

and

$$\sigma_{xy}^2(z) = \langle xy \rangle = \frac{\int_{-\infty}^{\infty} \int_{-\infty}^{\infty} E(x, y, z) [x - \bar{x}(z)][y - \bar{y}(z)] \, dx \, dy}{\int_{-\infty}^{\infty} \int_{-\infty}^{\infty} E(x, y, z) \, dx \, dy} \tag{5}$$

Note 1 to entry: For practical application, the infinite integration limits are reduced in a specific manner as given in [Clause 7](#).

Note 2 to entry: $\sigma_{xy}^2(z)$ is a symbolic notation, and not a true square. This quantity can take positive, negative or zero value.

Note 3 to entry: The angular brackets are the operator notations as used in ISO 11146-2 and ISO/TR 11146-3.

3.3 principal axes

x', y'

<power density distribution> axes of the maximum and minimum beam extent based on the second order moments of the power density distribution in a cross section of the beam

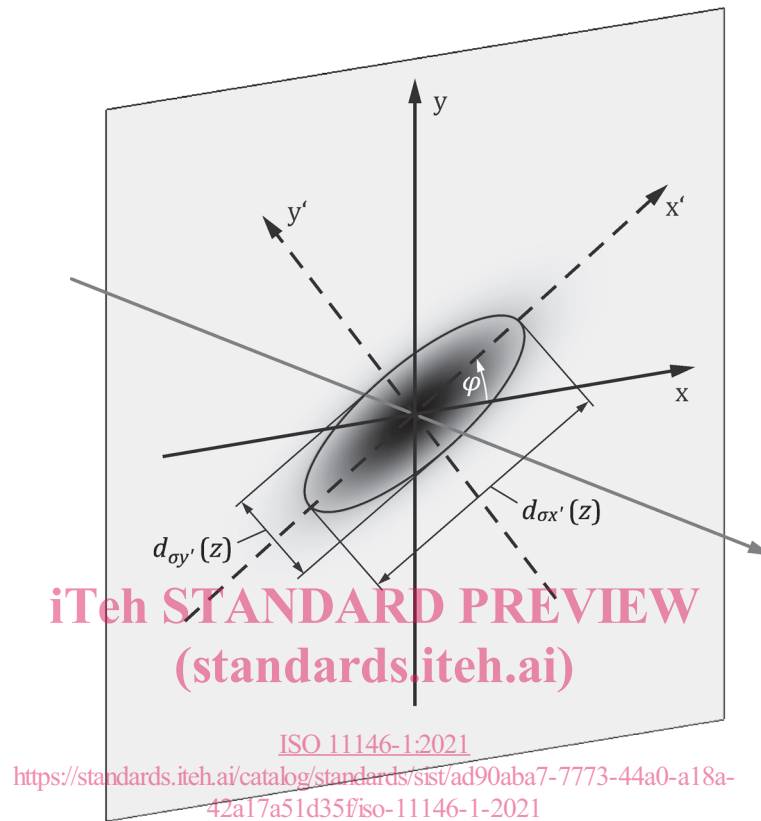

Figure 1 — Beam profile with the laboratory and principle axes coordinate systems

Note 1 to entry: The axes of maximum and minimum extent are always perpendicular to each other.

Note 2 to entry: Unless otherwise stated, in this document x' is the principal axis which is closer to the x -axis of the laboratory coordinate system, and y' is the principal axis which is closer to the y -axis of the laboratory coordinate system.

Note 3 to entry: If the principal axes make the angle $\pi/4$ with the x - and y -axes of the laboratory coordinate system, then the x' -axis is by convention the direction of maximum extent.

Note 4 to entry: See [Figure 1](#).

3.4 azimuthal orientation

φ

<power density distribution> azimuthal angle between the x -axis of the laboratory system and the principal axis x'

**3.5
beam widths**

$$d_{\sigma x'}(z_{0x'}), d_{\sigma y'}(z_{0y'})$$

extent of a power density distribution in a cross-section of the beam at an axial location z along the principal axes x' and y' , respectively, based on the second order moments of the power density distribution

Note 1 to entry: This definition differs from that given in ISO 11145:2018, 3.5.2, where the beam widths are defined only in the laboratory system, whereas for the purposes of this document the beam widths are defined in the *principal axes* (3.3) system of the beam.

Note 2 to entry: Formulae for calculation of the beam widths from the three second order moments are given in 7.2.

**3.6
beam ellipticity**

$$\varepsilon(z)$$

parameter for quantifying the circularity or squareness of a power (energy) density distribution at an axial location z

$$\varepsilon(z) = \frac{\min[d_{\sigma x'}(z), d_{\sigma y'}(z)]}{\max[d_{\sigma x'}(z), d_{\sigma y'}(z)]}$$

Note 1 to entry: It follows that $0 < \varepsilon(z) \leq 1$.

Note 2 to entry: If $\varepsilon(z) \geq 0,87$, elliptical distributions can be regarded as circular.

Note 3 to entry: In case of a rectangular distribution, ellipticity is often referred to as “aspect ratio”.

Note 4 to entry: In contrast to the definition given here, in literature the term “ellipticity” is sometimes related to $1 - \frac{d_{\sigma y'}(z)}{d_{\sigma x'}(z)}$. The definition given here has been chosen to be in concordance with the same definition of ellipticity in ISO 11145 and ISO 13694.

**3.7
circular power density distribution**

power density distribution having an ellipticity greater than or equal to 0,87

[SOURCE: ISO 11145:2018, 3.6.4]

**3.8
beam diameter**

$$d_{\sigma}(z)$$

extent of a circular power density distribution in a cross section of the beam at an axial location z , based on the second order moments

Note 1 to entry: Formulae for calculation of the beam diameter from the second order moments are given in 7.2.

**3.9
stigmatism**

property of a beam having circular power density distributions in any plane under free propagation and showing power density distributions after propagation through a cylindrical lens all having the same *azimuthal orientation* (3.4) as that lens

3.10 simple astigmatism

property of a non-stigmatic beam whose *azimuthal orientation* (3.4) is constant under free propagation, and which retains its original *azimuthal orientation* (3.4) after passing through a cylindrical optical element whose cylindrical axis is parallel to one of the *principal axes* (3.3) of the beam

Note 1 to entry: The *principal axes* (3.3) of a power density distribution corresponding to a beam with *simple astigmatism* (3.10) are called the *principal axes* (3.3) of that beam.

3.11 general astigmatism

property of a beam which is neither stigmatic nor simple astigmatic

Note 1 to entry: This document deals only with stigmatic and simple astigmatic beams. See ISO 11146-2 for general astigmatic beams.

3.12 beam waist locations

$z_{0x'}$, $z_{0y'}$, z_0

<simple astigmatic beams, stigmatic beams> location where the *beam widths* (3.5) or the *beam diameters* (3.8) reach their minimum values along the beam axis

Note 1 to entry: See [Figure 2](#).

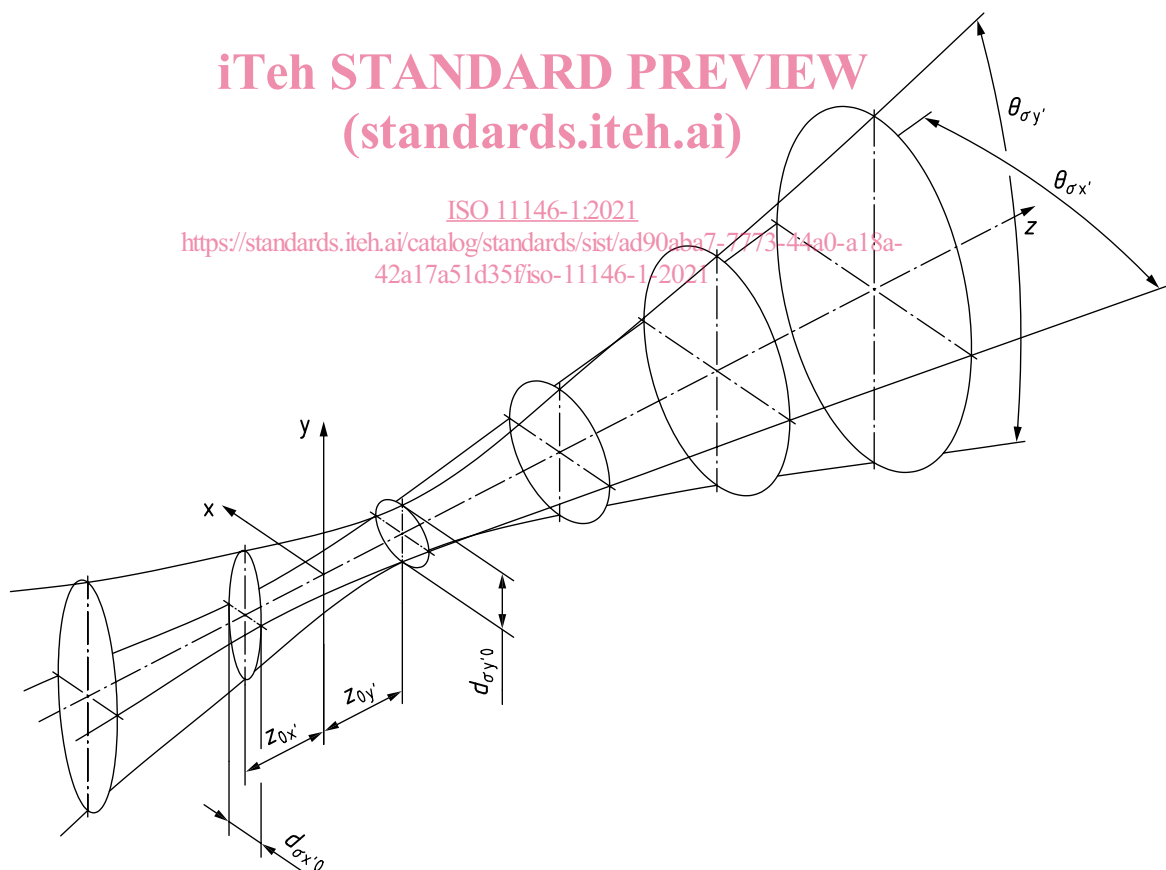

Figure 2 — Beam propagation parameters of a simple astigmatic beam

Note 2 to entry: In the case of general astigmatic beams, which are outside the scope of this document, this definition does not apply, see ISO 11146-2.

Note 3 to entry: For simple astigmatic beams the waist locations $z_{0x'}$ and $z_{0y'}$ corresponding to the *principal axes* (3.3), may or may not coincide.