



**SLOVENSKI STANDARD**  
**oSIST prEN ISO 5210:2023**  
**01-julij-2023**

---

**Industrijski ventili - Priključki vrtilnih pogonov na ventilih (ISO/FDIS 5210:2023)**

Industrial valves - Multi-turn valve actuator attachments (ISO/FDIS 5210:2023)

Industriearmaturen - Anschlüsse von Drehantrieben für Armaturen (ISO/FDIS 5210:2023)

Robinetterie industrielle - Raccordement des actionneurs multitours aux appareils de robinetterie (ISO/FDIS 5210:2023)

**Ta slovenski standard je istoveten z: prEN ISO 5210**

---

**ICS:**

23.060.01      Ventili na splošno                      Valves in general

**oSIST prEN ISO 5210:2023**                      **en,fr,de**



FINAL  
DRAFTINTERNATIONAL  
STANDARDISO/FDIS  
5210

ISO/TC 153

Secretariat: AFNOR

Voting begins on:  
**2023-05-16**Voting terminates on:  
**2023-08-08**

---

---

**Industrial valves — Multi-turn valve  
actuator attachments***Robinetterie industrielle — Raccordement des actionneurs multitours  
aux appareils de robinetterie***iTeh STANDARD PREVIEW**  
**(standards.iteh.ai)**[oSIST prEN ISO 5210:2023](https://standards.iteh.ai/catalog/standards/sist/c3ff202a-8007-4955-ac3a-dbf64c3b95b2/osist-pren-iso-5210-2023)[https://standards.iteh.ai/catalog/standards/sist/c3ff202a-8007-4955-ac3a-  
dbf64c3b95b2/osist-pren-iso-5210-2023](https://standards.iteh.ai/catalog/standards/sist/c3ff202a-8007-4955-ac3a-dbf64c3b95b2/osist-pren-iso-5210-2023)**ISO/CEN PARALLEL PROCESSING**

RECIPIENTS OF THIS DRAFT ARE INVITED TO SUBMIT, WITH THEIR COMMENTS, NOTIFICATION OF ANY RELEVANT PATENT RIGHTS OF WHICH THEY ARE AWARE AND TO PROVIDE SUPPORTING DOCUMENTATION.

IN ADDITION TO THEIR EVALUATION AS BEING ACCEPTABLE FOR INDUSTRIAL, TECHNOLOGICAL, COMMERCIAL AND USER PURPOSES, DRAFT INTERNATIONAL STANDARDS MAY ON OCCASION HAVE TO BE CONSIDERED IN THE LIGHT OF THEIR POTENTIAL TO BECOME STANDARDS TO WHICH REFERENCE MAY BE MADE IN NATIONAL REGULATIONS.

Reference number  
ISO/FDIS 5210:2023(E)

# iTeh STANDARD PREVIEW (standards.iteh.ai)

[oSIST prEN ISO 5210:2023](https://standards.iteh.ai/catalog/standards/sist/c3ff202a-8007-4955-ac3a-dbf64c3b95b2/osist-pren-iso-5210-2023)

<https://standards.iteh.ai/catalog/standards/sist/c3ff202a-8007-4955-ac3a-dbf64c3b95b2/osist-pren-iso-5210-2023>



## **COPYRIGHT PROTECTED DOCUMENT**

© ISO 2023

All rights reserved. Unless otherwise specified, or required in the context of its implementation, no part of this publication may be reproduced or utilized otherwise in any form or by any means, electronic or mechanical, including photocopying, or posting on the internet or an intranet, without prior written permission. Permission can be requested from either ISO at the address below or ISO's member body in the country of the requester.

ISO copyright office  
CP 401 • Ch. de Blandonnet 8  
CH-1214 Vernier, Geneva  
Phone: +41 22 749 01 11  
Email: [copyright@iso.org](mailto:copyright@iso.org)  
Website: [www.iso.org](http://www.iso.org)

Published in Switzerland

# Contents

	Page
<b>Foreword</b> .....	<b>iv</b>
<b>Introduction</b> .....	<b>v</b>
<b>1 Scope</b> .....	<b>1</b>
<b>2 Normative references</b> .....	<b>1</b>
<b>3 Terms and definitions</b> .....	<b>1</b>
<b>4 Maximum torques and thrusts</b> .....	<b>2</b>
<b>5 Flange dimensions</b> .....	<b>2</b>
<b>6 Designation</b> .....	<b>4</b>
<b>7 Dimensions of driving and driven components</b> .....	<b>4</b>
7.1 General.....	4
7.2 Dimensions for assemblies capable of transmitting both torque and thrust: Group A.....	5
7.3 Dimensions for assemblies capable of transmitting torque only: Group B.....	6
7.4 Dimensions for assemblies capable of transmitting torque only: Group C.....	7
7.5 Dimensions for assemblies capable of transmitting torque only: Group D.....	8
7.6 Dimensions for assemblies capable of transmitting thrust only: Group Linear actuators.....	9
<b>Annex A (informative) Explanation of calculations</b> .....	<b>11</b>
<b>Annex B (normative) Dimensions of keys and keyways</b> .....	<b>13</b>
<b>Bibliography</b> .....	<b>19</b>

oSIST prEN ISO 5210:2023

<https://standards.iteh.ai/catalog/standards/sist/c3ff202a-8007-4955-ac3a-dbf64c3b95b2/osist-pren-iso-5210-2023>

## ISO/FDIS 5210:2023(E)

### Foreword

ISO (the International Organization for Standardization) is a worldwide federation of national standards bodies (ISO member bodies). The work of preparing International Standards is normally carried out through ISO technical committees. Each member body interested in a subject for which a technical committee has been established has the right to be represented on that committee. International organizations, governmental and non-governmental, in liaison with ISO, also take part in the work. ISO collaborates closely with the International Electrotechnical Commission (IEC) on all matters of electrotechnical standardization.

The procedures used to develop this document and those intended for its further maintenance are described in the ISO/IEC Directives, Part 1. In particular, the different approval criteria needed for the different types of ISO documents should be noted. This document was drafted in accordance with the editorial rules of the ISO/IEC Directives, Part 2 (see [www.iso.org/directives](http://www.iso.org/directives)).

ISO draws attention to the possibility that the implementation of this document may involve the use of (a) patent(s). ISO takes no position concerning the evidence, validity or applicability of any claimed patent rights in respect thereof. As of the date of publication of this document, ISO had not received notice of (a) patent(s) which may be required to implement this document. However, implementers are cautioned that this may not represent the latest information, which may be obtained from the patent database available at [www.iso.org/patents](http://www.iso.org/patents). ISO shall not be held responsible for identifying any or all such patent rights.

Any trade name used in this document is information given for the convenience of users and does not constitute an endorsement.

For an explanation of the voluntary nature of standards, the meaning of ISO specific terms and expressions related to conformity assessment, as well as information about ISO's adherence to the World Trade Organization (WTO) principles in the Technical Barriers to Trade (TBT), see [www.iso.org/iso/foreword.html](http://www.iso.org/iso/foreword.html).

This document was prepared by Technical Committee ISO/TC 153, *Valves*, in collaboration with the European Committee for Standardization (CEN) Technical Committee CEN/TC 69, *Industrial valves*, in accordance with the Agreement on technical cooperation between ISO and CEN (Vienna Agreement).

This third edition cancels and replaces the second edition (ISO 5210:2017), which has been technically revised.

The main changes are as follows:

- dimensions and tolerances for keys and keyways were added in a new [Annex B](#);
- a reference to the new [Annex B](#) was added in [7.3](#) and [7.5](#);
- editorial changes were made.

Any feedback or questions on this document should be directed to the user's national standards body. A complete listing of these bodies can be found at [www.iso.org/members.html](http://www.iso.org/members.html).

## Introduction

The purpose of this document is to establish certain basic requirements for the attachment of multi-turn actuators, in order to define the interface between actuator and valve.

This document is, in general, considered in conjunction with the specific requirements which may be agreed between the parties concerned.

NOTE 1 In this document, the term “valve” can also be understood to include “valve with an intermediate support” [see [Figure 1 b](#)].

NOTE 2 When a combination of a multi-turn actuator and separate multi-turn/linear gearbox is coupled to form an actuator, the multi-turn attachment to the gearbox is in accordance with this document [see [Figures 1 c](#) and [1 d](#)]. A combination of a multi-turn actuator with integral multi-turn/linear gearbox supplied as an actuator is in accordance with [Figures 1 a](#) and [1 b](#)).

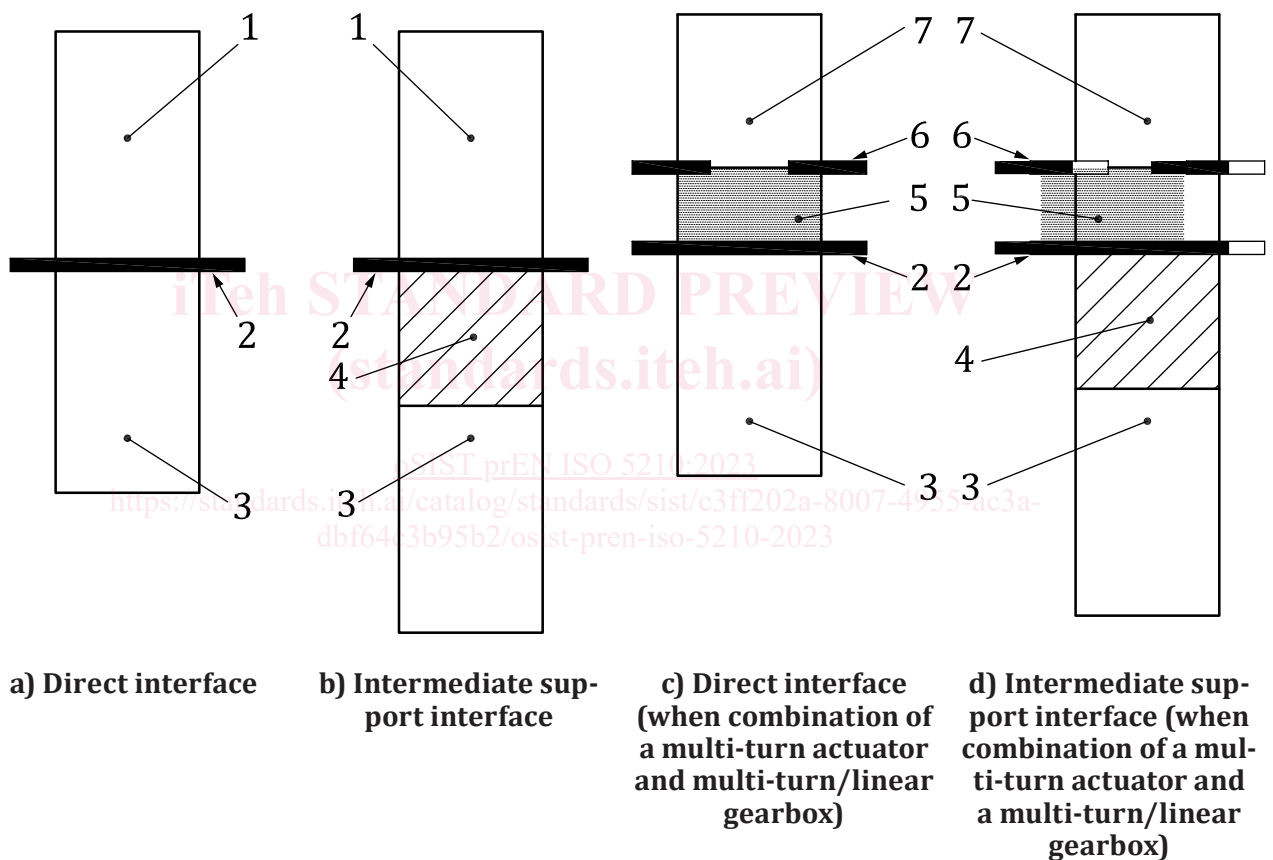

**Figure 1 — Interface between multi-turn/linear actuator and valve**





# Industrial valves — Multi-turn valve actuator attachments

## 1 Scope

This document specifies the requirements for the attachment of multi-turn actuators to valves.

Throughout this document, “actuator” can be understood as “actuator and/or gearbox” providing a multi-turn and/or linear output.

It specifies:

- flange dimensions necessary for the attachment of actuators to industrial valves [see [Figure 1 a](#)] or to intermediate supports [see [Figure 1 b](#)];
- those driving component dimensions of actuators which are necessary to attach them to the driven components;
- reference values for torque and thrust for flanges having the dimensions specified in this document.

## 2 Normative references

The following documents are referred to in the text in such a way that some or all of their content constitutes requirements of this document. For dated references, only the edition cited applies. For undated references, the latest edition of the referenced document (including any amendments) applies.

ISO 273, *Fasteners — Clearance holes for bolts and screws*

## 3 Terms and definitions

For the purposes of this document, the following terms and definitions apply.

ISO and IEC maintain terminology databases for use in standardization at the following addresses:

- ISO Online browsing platform: available at <https://www.iso.org/obp>
- IEC Electropedia: available at <https://www.electropedia.org/>

### 3.1

#### **actuator**

any device designed for attachment to a general-purpose industrial valve in order to provide for the operation of the valve

Note 1 to entry: The device is designed to operate using motive energy which may be electrical, pneumatic, hydraulic, manual, etc., or a combination of these. Movement is limited by travel, *torque* ([3.4](#)) and/or *thrust* ([3.5](#)).

### 3.2

#### **multi-turn actuator**

*actuator* ([3.1](#)) which transmits *torque* ([3.4](#)) to the valve for at least one revolution and may be capable of withstanding *thrust* ([3.5](#))

Note 1 to entry: An actuator may be a combination of a multi-turn actuator and multi-turn gearbox.

## ISO/FDIS 5210:2023(E)

### 3.3

#### linear actuator

actuator (3.1) which transmits *thrust* (3.5) to the valve for a defined linear stroke

Note 1 to entry: An actuator may be a combination of a *multi-turn actuator* (3.2) and linear gearbox.

### 3.4

#### torque

turning moment transmitted through the mounting flanges and couplings

Note 1 to entry: Torque is expressed in newton-metres.

### 3.5

#### thrust

axial force transmitted through the mounting flanges and couplings

Note 1 to entry: Thrust is expressed in kilonewtons.

## 4 Maximum torques and thrusts

The torque and thrust shall comply with the values listed in [Table 1](#) which represent the maximum torques and thrusts which can be transmitted simultaneously through the mounting flanges and couplings. They are based upon specified criteria.

**Table 1 — Maximum torque and thrust values**

Flange type	Torque [Nm]	Thrust [kN]
F05	20	10
F07	40	20
F10	100	40
F12	250	70
F14	400	100
F16	700	150
F25	1 200	200
F30	2 500	325
F35	5 000	700
F40	10 000	1 100
F48	20 000	2 000
F60	40 000	4 000

The values specified in [Table 1](#) have been defined on the basis of bolts in tension at a stress of 290 MPa and a coefficient of friction of 0,2 between the mounting interface. All variations in these defined parameters lead to variations of the transmittable torque and/or thrust values. See [Annex A](#) for an explanation on the calculation method.

The selection of flange size for a particular application should take account of additional torques and/or thrust that may be generated at the valve stem because of sizing, safety factors, inertia or other similar factors. Specifically, the torque and thrust generated at the maximum output torque and/or thrust of the selected actuator shall be calculated and considered in the selection of the flange along with the ability of the valve and actuator to withstand such torque and thrust forces.

## 5 Flange dimensions

Flanges for actuator attachment shall comply with the dimensions shown in [Figure 2](#) and given in [Table 2](#). The method of attachment shall be by means of studs or through bolting. When through

bolting is used, the diameter of the clearance holes shall permit the use of bolts of a size given by the corresponding dimension  $d_4$  in [Table 2](#).

Holes for the studs/bolts shall be positioned off-centre (see [Figure 3](#) and [Table 3](#)), shall be equi-spaced and shall conform to the requirements of ISO 273.

The interface on the valve shall have a recess corresponding to the diameter  $d_2$ . A spigot on the actuator is optional.

The minimum values for dimension  $h_2$  shown in [Table 2](#) apply to flanges having material of proof stress  $R_e \geq 200$  MPa. The minimum values for dimension  $h_2$  applied to flanges having materials of proof stress  $R_e \leq 200$  MPa shall be agreed between manufacturer and purchaser. The minimum values for dimension  $h_3$  shall be at least  $1 \times d_4$ .

Dimension  $d_1$  has been based on providing sufficient landing for the nuts and bolt heads where applicable. Such landing is defined as a radius from the bolt hole centre with the dimension  $(d_1 - d_3) / 2$ , and is a minimum. The flange shape of both valve and actuator outside these areas of landing is left to the option of the manufacturer.

The dimensions and bolting material are based on bolts in tension at a maximum stress of 290 MPa. On agreement, between the manufacturer/supplier and purchaser, bolting material with different tensile strength can be used, with no dimensional changes but with potential variation of the transmittable torque and thrust value.

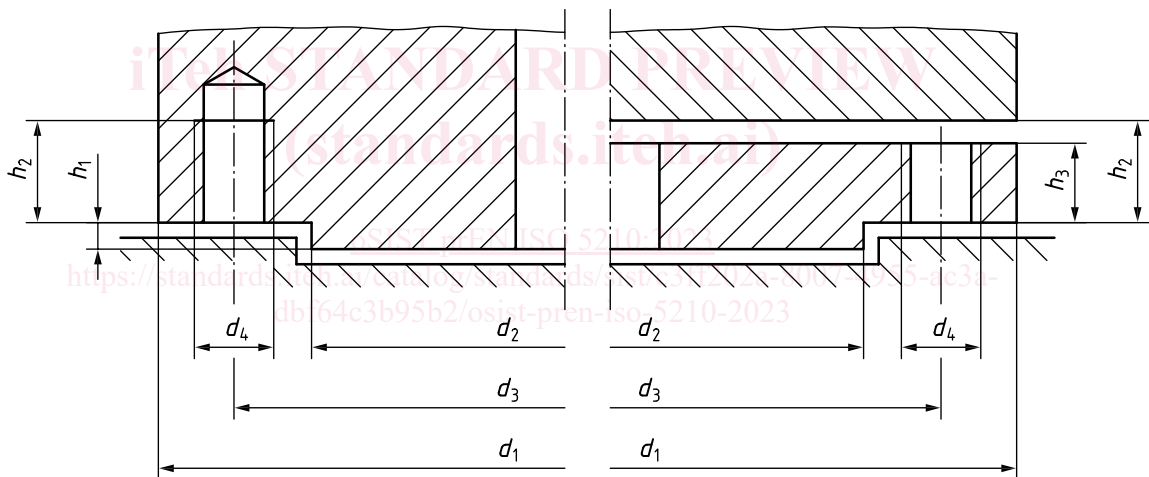

Figure 2 — Flange dimensions

Table 2 — Flange dimensions

Dimensions in millimetres

Flange type	Dimensions							Number of studs or bolts $n$
	$d_1$ min.	$d_2^a$	$d_3$	$d_4$	$h_1$ max.	$h_2$ min.	$h_3$ min.	
F05	Ø65	Ø35	Ø50	M6	3	9	6	4
F07	Ø90	Ø55	Ø70	M8	3	12	8	4
F10	Ø125	Ø70	Ø102	M10	3	15	10	4
F12	Ø150	Ø85	Ø125	M12	3	18	12	4
F14	Ø175	Ø100	Ø140	M16	4	24	16	4
F16	Ø210	Ø130	Ø165	M20	5	30	20	4
F25	Ø300	Ø200	Ø254	M16	5	24	16	8

<sup>a</sup>  $d_2$  shall be manufactured within the diameter tolerance f8.