



Designation: F2917 – 11

Standard Specification for Bicycle Trailer Cycles Designed for Human Passengers¹

This standard is issued under the fixed designation F2917; the number immediately following the designation indicates the year of original adoption or, in the case of revision, the year of last revision. A number in parentheses indicates the year of last reapproval. A superscript epsilon (ϵ) indicates an editorial change since the last revision or reapproval.

1. Scope

1.1 This specification covers trailer cycles, intended to be pulled behind bicycles, with seat post attachment, in order to transport children. It includes test methods for confirming that this specification is satisfied.

1.2 The values stated in SI units are to be regarded as the standard. The units given in parentheses are for information only.

1.3 *The following safety caveat applies to the chemical, mechanical, or physical, or a combination thereof, test methods described herein and is meant specifically for those performing the tests (in an effort to provide them with notice to take the appropriate precautions when conducting the tests). This standard does not purport to address all of the safety concerns, if any, associated with its use. It is the responsibility of the user of this standard to establish appropriate safety and health practices and determine the applicability of regulatory limitations prior to use.*

2. Referenced Documents

2.1 ASTM Standards:²

- B117 Practice for Operating Salt Spray (Fog) Apparatus
- D1230 Test Method for Flammability of Apparel Textiles (Withdrawn 2010)³
- D4329 Practice for Fluorescent UV Exposure of Plastics
- F2043 Classification for Bicycle Usage
- G23 Practice for Operating Light-Exposure Apparatus (Carbon-Arc Type) With and Without Water for Exposure of Nonmetallic Materials (Withdrawn 2000)³

2.2 ANSI Standards:⁴

- ANSI Z535.4 Product Safety Signs and Labels

ANSI Z535.6 Product Safety Information in Product Manuals, Instructions, and Other Collateral Materials

2.3 Federal Standards:⁵

- Title 16, CFR 1303 Lead in Coatings
- Title 16, CFR 1500.3(b)(4)(i) Hazardous Substance
- Title 16, CFR 1500.48 Sharp Points
- Title 16, CFR 1500.49 Sharp Edges
- Title 16, CFR 1501 Small Parts
- Title 16, CFR 1512 Requirements for Bicycles, Sections: 1512.18(n), Reflector Test

3. Terminology

3.1 Definitions of Terms Specific to This Standard:

- 3.1.1 *lead bicycle*—the bicycle used to tow the trailer cycle.
- 3.1.2 *normal use*—applications described as intended use for the product found within the manufacturer's instructional literature.
- 3.1.3 *normal use temperatures*—temperature range within which it should be anticipated that the trailer cycle may be used to transport children. The range is from -7 to $+50^{\circ}\text{C}$ ($\pm 2^{\circ}$).
- 3.1.4 *occupant*—a child or person who is riding the trailer cycle.
- 3.1.5 *rider*—a person who controls the lead bicycle to which the trailer cycle is attached, and who is responsible for control of the trailer cycle.
- 3.1.6 *trailer cycle*—a transporting device, with a single rear wheel, designed to provide a tandem bicycle riding experience for one or two children. The device includes the fastening arrangements for attaching and towing it behind a lead bicycle.
- 3.1.7 *useful product lifecycle*—allowable range of time for continued use of a product from the date of manufacture as described within the manufacturer's instructional literature.

4. Requirements

4.1 *General*—Trailer cycles shall be designed and manufactured such that components with which an occupant may come in contact do not cause injury when used in accordance with the manufacturer's instructions. Exposed surfaces shall be free

¹ This specification is under the jurisdiction of ASTM Committee F08 on Sports Equipment, Playing Surfaces, and Facilities and is the direct responsibility of Subcommittee F08.10 on Bicycles.

Current edition approved June 1, 2011. Published August 2011. DOI: 10.1520/F2917-11.

² For referenced ASTM standards, visit the ASTM website, www.astm.org, or contact ASTM Customer Service at service@astm.org. For *Annual Book of ASTM Standards* volume information, refer to the standard's Document Summary page on the ASTM website.

³ The last approved version of this historical standard is referenced on www.astm.org.

⁴ Available from American National Standards Institute (ANSI), 25 W. 43rd St., 4th Floor, New York, NY 10036, http://www.ansi.org.

⁵ Available from U.S. Government Printing Office Superintendent of Documents, 732 N. Capitol St., NW, Mail Stop: SDE, Washington, DC 20401, http://www.access.gpo.gov.

from burrs, sharp edges, and points. Refer to Title 16, CFR 1500, Parts 48 and 49, and Title 16, CFR 1501. Trailer cycles shall be equipped with rear reflectors; pedal reflectors; side reflectors on the wheel. Refer to Title 16, CFR 1512, Parts 16 and 18(n).

4.2 *Equipment*—Trailer cycles shall be equipped with the following equipment: handlebar, seat, pedals, and a drivetrain to provide human power to the rear wheel. The seatpost shall have a minimum insertion marking as defined in Title 16, CFR 1512.

4.3 *Materials:*

4.3.1 All nonmetallic materials that compose structural components will be subjected to either (1) 100 h of accelerated weathering in accordance with Method 1 of Practice G23, or (2) 60 h of accelerated weathering in accordance with Practice D4329 prior to any testing.

4.3.2 All painted materials shall comply with Title 16, CFR 1303.

4.3.3 Mechanical properties of materials used in the construction of trailer cycles shall not fail as a result of exposure to the temperature variances defined as normal use temperatures in 3.1.6 under normal use applications or within useful product lifecycle.

4.3.4 Materials known to be a hazardous substance, as defined in Title 16, CFR 1500.3(b)(4)(i), shall not be used.

5. Test Methods

5.1 *Test Order*—Perform the lean angle test first, then torsion fatigue test, and then the bump fatigue test on the same sample.

5.2 *Lean Angle Test:*

5.2.1 With the trailer cycle attached to a dummy lead bike simulated by a post mounted to a hinge on the floor as in Fig. 1, lean the lead bicycle 25° in each direction.

5.2.2 Ensure the trailer cycle pedals, with the foot surface of the pedal horizontal and the pedal crank in its lowest position, do not hit the ground.

5.3 *Torsion Fatigue Test*—The trailer cycle shall be mounted for fatigue testing as in Fig. 2.

5.3.1 The trailer cycle wheel is removed.

5.3.2 A fixture is created to apply a displacement load perpendicular to the ground and perpendicular to the centerline of the trailer cycle, through the rear wheel dropouts.

5.3.3 The trailer cycle shall be mounted vertically to a rigidly mounted dummy seatpost set at $71 \pm 2^\circ$ from horizontal at the minimum height recommended by the manufacturer.

5.3.4 A fully reversing torsion load shall be applied to the trailer cycle calculated as follows:

$$\text{Torsion Load} = \tag{1}$$

$$(137 \text{ Nm}/31.75 \text{ kg}) \times$$

(maximum recommended occupant weight for trailer cycle in kg)

5.3.5 The test shall be repeated for a total of 20 000 cycles.

5.3.6 During testing, the technician shall look for cracks or fractures or separation on the entire unit. If the trailer cycle hitch is slipping, the test shall be paused and the trailer cycle shall be realigned to vertical.

5.3.7 Remove the trailer cycle from the test equipment and inspect the frame assembly. No part of the assembly shall have failed, or have a visible fracture or crack.

5.4 *Bump Fatigue Test:*

5.4.1 The trailer cycle shall be tested as in Fig. 3.

5.4.2 The trailer cycle shall be fitted with weights totaling 125 % of the maximum recommended weight, and distributed as in Fig. 3. Load B shall be applied to one side of the

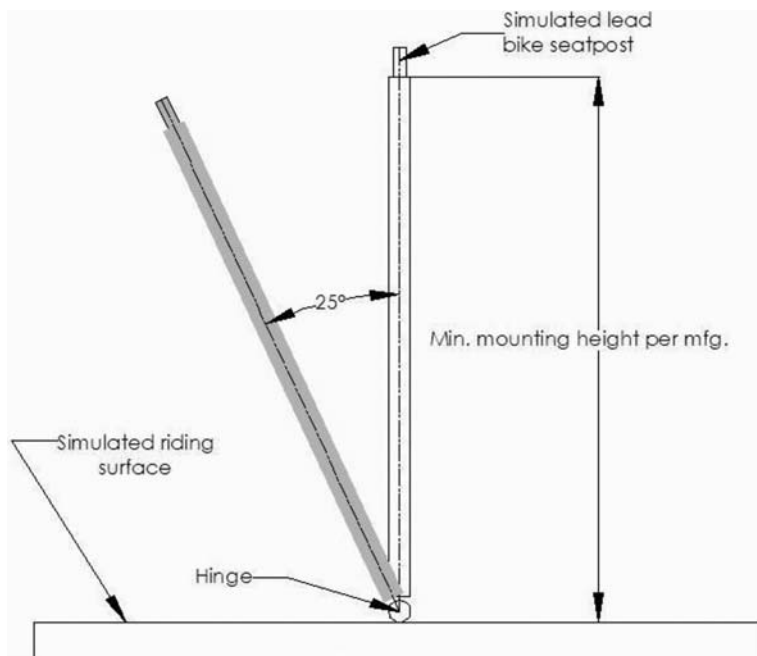

FIG. 1 Lean Angle Test Fixture

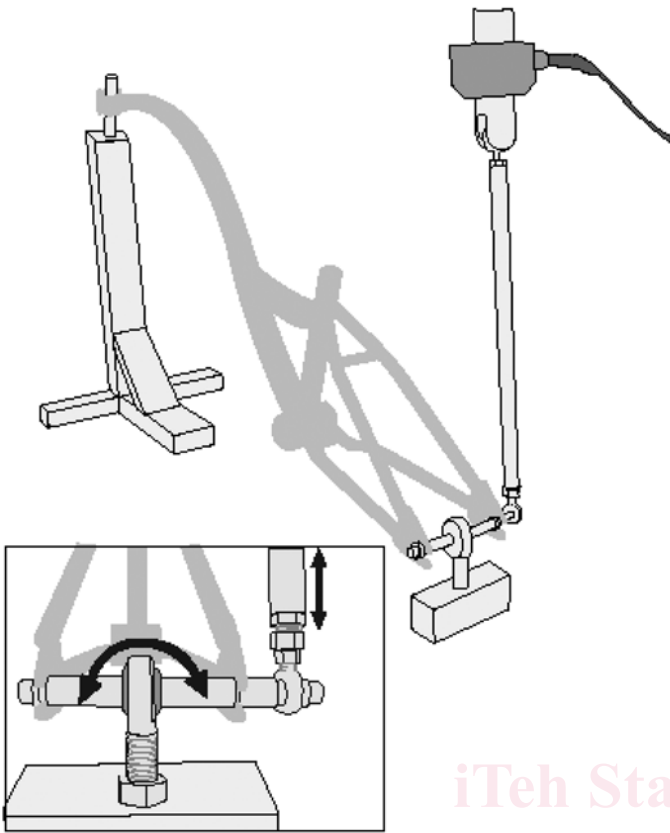

FIG. 2 Torsion Fatigue Test of the Trailer Cycle with Connection to Dummy Seatpost

frame cracks and any signs of deformation on the entire unit. If the hitch slips, resulting in less than vertical alignment, the trailer cycle shall be realigned to vertical. All notes shall be recorded on the report.

5.4.5 Record the hitch mounting height, and where the measurement was taken.

5.4.6 Testing shall be stopped at 10 000 cycles or failure.

5.4.7 Remove the trailer cycle from the test equipment and inspect the wheel and frame assemblies. No part of these assemblies shall have failed, or have a visible fracture or crack.

6. Marking, Labeling, and Instructions

6.1 *General*—All trailer cycles shall be permanently marked with information concerning the safe usage of the trailer cycle. The markings shall be in locations easily visible to the user. The trailer cycle shall also be accompanied by instructions on the proper assembly (where assembly is required), attachment, usage, removal, disassembly, storage, and maintenance of the trailer cycle, and general bicycle safety. Instructions shall be written in the native language(s) of the country(s) in which the trailer will be offered for sale, and attached to the trailer, at the time of purchase.

6.2 Where Cautions, Warnings, or Danger signals are attached to the trailer cycle, they shall comply with the requirements of ANSI Z535.4. Where Cautions, Warnings, or Danger signals are in collateral materials, they shall comply with ANSI Z535.6.

6.3 *Marking and Labeling*—All trailer cycles shall be permanently marked with durable materials, resistant to weather, fading, and abrasion with the following information:

6.3.1 Name and address of the manufacturer or importer.

6.3.2 Month and year of manufacture.

6.3.3 Recommended maximum safe towing speed.

6.3.4 Where the trailer cycle manufacturer requires a different pressure than that provided by the tire manufacturer, a label shall be present within 50 mm of the tire valve.

6.3.5 Maximum weight capacity of trailer cycle.

6.3.6 Required passenger-fitted safety equipment, including a helmet that complies with a recognized bicycle helmet performance standard.

6.3.7 Conditions for use including proper attachment to lead bike, and fastener check, and a reference to the owners manual.

6.3.8 Fig. 4 is an example of a typical label.

6.4 *Instructions*:

6.4.1 *Assembly*—If the trailer cycle is sold in an unassembled or partially assembled condition, the manufacturer shall provide instructions on how to complete the assembly so that the trailer cycle can be attached to the bicycle and be ready to accept passengers.

6.4.2 *Attachment*—The instructions shall include information on the procedures to follow in attaching the trailer cycle to the lead bicycle.

6.4.3 *Suitability of Lead Bicycle*—The instructions shall identify the features of the lead bicycle required for proper coupling and list the features suggested for proper towing (for example, good brakes, wheel size, etc.).

handlebar. It shall be mounted to the handlebar directly, and positioned so the weight is centered 50 mm from the outside end of the handlebar.

5.4.3 The tire shall be inflated to the maximum pressure per the trailer cycle manufacturer.

5.4.4 The test equipment shall be capable of simulating the passing of the trailer cycle over a bump. The device is a flywheel or drum tester with the trailer cycle positioned so the wheel sits atop the flywheel. The wheel axle shall be aligned 30 to 45 mm behind the axis of the flywheel. The flywheel shall have a minimum circumference of 2.2 m (diameter of 700 mm). The flywheel shall be round within a tolerance of less than 5 mm. The flywheel may have multiple bumps only if the running distance between bumps is greater than 2.2 m. The horizontal speed at which the trailer's axle approaches the bump shall be no more than 13 km/h (8 mph) and no less than 12 km/h (7.5 mph). Mount the trailer cycle onto the test equipment as previously described, and conduct the test for 10 000 cycles of the wheel passing over the bump(s). The trailer cycle shall be mounted to be as close to vertical as possible. The hitch shall be mounted at the lowest height per the manufacturer typical of recommended use. The drum should be turning at test speed, and then the trailer cycle lowered onto the moving drum. The test initially shall be run under observation for 5 min, and then stopped and the trailer cycle inspected. The test shall then run 25 min, stopped for inspection and thereafter the trailer cycle shall be inspected every 60 min. During inspection the technician shall look for