



**SLOVENSKI STANDARD**  
**oSIST prEN ISO 16484-4:2024**  
**01-februar-2024**

---

**Sistemi za avtomatizacijo in regulacijo stavb (BACS) - 4. del: Izvedba regulacije (ISO/DIS 16484-4:2023)**

Building automation and control systems (BACS) - Part 4: Control applications (ISO/DIS 16484-4:2023)

Systeme der Gebäudeautomation - Steuerungsanwendung (ISO/DIS 16484-4:2023)

Systèmes d'automatisation et de contrôle des bâtiments (BACS) - Partie 4: Applications de contrôle (ISO/DIS 16484-4:2023)

**Ta slovenski standard je istoveten z: prEN ISO 16484-4**

---

<https://standards.iteh.ai/catalog/standards/sist/afadde45-4d54-4424-86d2-f270d6021e33/osist-pren-iso-16484-4-2024>

**ICS:**

35.240.67	Uporabniške rešitve IT v gradbeništvu	IT applications in building and construction industry
91.140.01	Napeljave v stavbah na splošno	Installations in buildings in general

**oSIST prEN ISO 16484-4:2024**

**en,fr,de**



# DRAFT INTERNATIONAL STANDARD

## ISO/DIS 16484-4

ISO/TC 205

Secretariat: ANSI

Voting begins on:  
2023-12-20Voting terminates on:  
2024-03-13

---

---

## Building automation and control systems (BACS) —

### Part 4: Control applications

*Systèmes d'automatisation et de régulation des bâtiments —*  
*Partie 4: Applications de régulation*

ICS: 35.240.67; 91.040.01

iTeh Standards  
(<https://standards.iteh.ai>)  
Document Preview

[oSIST prEN ISO 16484-4:2024](https://standards.iteh.ai/catalog/standards/sist/afaddc45-4d54-4424-86d2-f270d6021e33/osist-pren-iso-16484-4-2024)

<https://standards.iteh.ai/catalog/standards/sist/afaddc45-4d54-4424-86d2-f270d6021e33/osist-pren-iso-16484-4-2024>

This document is circulated as received from the committee secretariat.

THIS DOCUMENT IS A DRAFT CIRCULATED FOR COMMENT AND APPROVAL. IT IS THEREFORE SUBJECT TO CHANGE AND MAY NOT BE REFERRED TO AS AN INTERNATIONAL STANDARD UNTIL PUBLISHED AS SUCH.

IN ADDITION TO THEIR EVALUATION AS BEING ACCEPTABLE FOR INDUSTRIAL, TECHNOLOGICAL, COMMERCIAL AND USER PURPOSES, DRAFT INTERNATIONAL STANDARDS MAY ON OCCASION HAVE TO BE CONSIDERED IN THE LIGHT OF THEIR POTENTIAL TO BECOME STANDARDS TO WHICH REFERENCE MAY BE MADE IN NATIONAL REGULATIONS.

RECIPIENTS OF THIS DRAFT ARE INVITED TO SUBMIT, WITH THEIR COMMENTS, NOTIFICATION OF ANY RELEVANT PATENT RIGHTS OF WHICH THEY ARE AWARE AND TO PROVIDE SUPPORTING DOCUMENTATION.

**ISO/CEN PARALLEL PROCESSING**



Reference number  
ISO/DIS 16484-4:2023(E)

© ISO 2023

iTeh Standards  
(<https://standards.iteh.ai>)  
Document Preview

[oSIST prEN ISO 16484-4:2024](https://standards.iteh.ai/catalog/standards/sist/afaddc45-4d54-4424-86d2-f270d6021e33/osist-pren-iso-16484-4-2024)

<https://standards.iteh.ai/catalog/standards/sist/afaddc45-4d54-4424-86d2-f270d6021e33/osist-pren-iso-16484-4-2024>



**COPYRIGHT PROTECTED DOCUMENT**

© ISO 2023

All rights reserved. Unless otherwise specified, or required in the context of its implementation, no part of this publication may be reproduced or utilized otherwise in any form or by any means, electronic or mechanical, including photocopying, or posting on the internet or an intranet, without prior written permission. Permission can be requested from either ISO at the address below or ISO's member body in the country of the requester.

ISO copyright office  
CP 401 • Ch. de Blandonnet 8  
CH-1214 Vernier, Geneva  
Phone: +41 22 749 01 11  
Email: [copyright@iso.org](mailto:copyright@iso.org)  
Website: [www.iso.org](http://www.iso.org)

Published in Switzerland

# Contents

	Page
<b>Foreword</b> .....	<b>vi</b>
<b>Introduction</b> .....	<b>vii</b>
<b>1 Scope</b> .....	<b>1</b>
<b>2 Normative references</b> .....	<b>1</b>
<b>3 Terms and definitions</b> .....	<b>1</b>
<b>4 Abbreviations</b> .....	<b>3</b>
<b>5 Functional specifications having an impact on energy performance, comfort, and operational requirements of buildings</b> .....	<b>5</b>
5.1 Heating control.....	5
5.1.1 Emission control.....	5
5.1.2 Emission control for TABS (heating mode).....	8
5.1.3 Control of distribution network hot water temperature (supply or return).....	11
5.1.4 Control of distribution pumps in networks.....	13
5.1.5 Intermittent control of emission and/or distribution.....	16
5.1.6 Heat generator control (combustion and district heating).....	19
5.1.7 Heat generator control (heat pump).....	20
5.1.8 Heat generator control (outdoor unit).....	22
5.1.9 Sequencing of different heat generators.....	23
5.1.10 Control of Thermal Energy Storage (TES) charging.....	25
5.1.11 Hydronic balancing heating distribution (including contribution to balancing to the emission side).....	26
5.2 Domestic hot water supply control.....	29
5.2.1 Control of DHW storage charging with direct electric heating or integrated electric heat pump.....	29
5.2.2 Control of DHW storage charging using hot water generation.....	30
5.2.3 Control of DHW storage charging with solar collector and supplementary heat generation.....	31
5.2.4 Control of DHW circulation pump.....	33
5.3 Cooling control.....	34
5.3.1 Emission Control.....	34
5.3.2 Emission control for TABS (cooling mode).....	37
5.3.3 Control of distribution network chilled water temperature (supply or return).....	40
5.3.4 Control of distribution pumps in hydraulic networks.....	41
5.3.5 Intermittent Control of Emission and/or Distribution.....	43
5.3.6 Interlock between heating and cooling control of emission and/or distribution.....	47
5.3.7 Generator control for cooling.....	48
5.3.8 Sequencing of different chillers (generators for chilled water).....	49
5.3.9 Control of Thermal Energy Storage (TES) charging.....	51
5.3.10 Hydronic balancing cooling distribution (including contribution to balancing to the emission side).....	52
5.4 Ventilation and air conditioning control.....	54
5.4.1 Supply air flow control at the room level.....	54
5.4.2 Room air temperature control by the ventilation system (all-air systems; combination with static systems as cooling ceiling, radiators etc.).....	57
5.4.3 Coordination of room air temperature control by ventilation and by static systems.....	58
5.4.4 Outside air flow control.....	59
5.4.5 Air flow or pressure control at the air handler level.....	60
5.4.6 Heat recovery control (icing protection).....	64
5.4.7 Heat recovery control (prevention of overheating).....	64

## ISO/DIS 16484-4:2023(E)

5.4.8	Free mechanical cooling.....	65
5.4.9	Supply air temperature control at the air handling unit level.....	67
5.4.10	Humidity control.....	69
5.5	Lighting control.....	70
5.5.1	Occupancy control.....	70
5.5.2	Light level/Daylight control (daylight harvesting).....	72
5.6	Blind control.....	74
5.6.1	Type 1 – Motorized operation of blind with manual control.....	74
5.6.2	Type 2 – Motorized operation of blind with automatic control.....	75
5.6.3	Type 3 – Combined light/blind/HVAC control.....	76
<b>6</b>	<b>Functional elements.....</b>	<b>78</b>
6.1	Sensor Functions.....	78
6.1.1	Air quality measurement.....	78
6.1.2	Air temperature measurement.....	79
6.1.3	Dewpoint monitoring.....	80
6.1.4	Humidity measurement.....	81
6.1.5	Brightness measurement.....	82
6.1.6	Precipitation detection.....	82
6.1.7	Presence detection.....	83
6.1.8	Window monitoring.....	84
6.1.9	Wind speed measurement.....	85
6.1.10	Real-time clock.....	86
6.1.11	Air volume flow measurement.....	87
6.1.12	Partition wall position sensor.....	87
6.2	Actuator Functions.....	88
6.2.1	Solar protection actuator.....	88
6.2.2	Drive Actuator.....	89
6.2.3	Lighting Actuator.....	91
6.3	Display and User Operation Functions.....	92
6.3.1	Operate Lighting.....	92
6.3.2	Operate Solar Protection.....	93
6.3.3	Operate Drive.....	94
6.3.4	Set Temperature setpoint.....	95
6.3.5	Display Current Temperature.....	96
6.3.6	Select room utilisation type.....	97
6.3.7	Set presence.....	98
6.4	Control Functions.....	99
6.4.1	Presence Evaluation.....	99
6.4.2	Predefined operation setting (scenario).....	100
6.4.3	Schedule.....	102
6.4.4	Manual Lighting Control.....	103
6.4.5	Timed Lighting Control.....	104
6.4.6	Partition wall control.....	105
6.4.7	Occupancy dependent lighting control.....	106
6.4.8	Daylight-dependent lighting.....	107
6.4.9	Constant-light control.....	109
6.4.10	Twilight control.....	111
6.4.11	Priority control.....	112
6.4.12	Automatic twilight control.....	114
6.4.13	Automatic solar control (simple solar protection).....	115
6.4.14	Slat tracking (complex solar protection).....	117
6.4.15	Shadow correction.....	119
6.4.16	Automatic thermal control.....	120
6.4.17	Weather protection.....	122
6.4.18	Energy mode selection.....	123
6.4.19	Energy mode selection with start optimisation.....	125
6.4.20	Setpoint calculation.....	127
6.4.21	Function selection.....	129

6.4.22	Temperature control (heating/cooling).....	131
6.4.23	Room supply air temperature cascade control.....	134
6.4.24	Fan control.....	136
6.4.25	Sequence control.....	138
6.4.26	Control value limiting.....	139
6.4.27	Air quality control.....	141
6.4.28	Night-time cooling.....	143
6.4.29	Volume flow control.....	144
6.4.30	Sun position calculation.....	146
6.4.31	Weather hazard assessment.....	146
6.4.32	Wind hazard detection.....	147
6.4.33	Icing hazard detection.....	148
6.4.34	Rain hazard detection.....	149
6.4.35	Solar edge tracking.....	149
6.4.36	Solar edge and slat tracking.....	150
6.4.37	Window state evaluation/Window group monitoring.....	151
6.4.38	Electric heating actuator.....	152
<b>Bibliography</b> .....		<b>154</b>

iTeh Standards  
(<https://standards.iteh.ai>)  
Document Preview

[oSIST prEN ISO 16484-4:2024](https://standards.iteh.ai/catalog/standards/sist/afaddc45-4d54-4424-86d2-f270d6021e33/osist-pren-iso-16484-4-2024)

<https://standards.iteh.ai/catalog/standards/sist/afaddc45-4d54-4424-86d2-f270d6021e33/osist-pren-iso-16484-4-2024>

## ISO/DIS 16484-4:2023(E)

### Foreword

ISO (the International Organization for Standardization) is a worldwide federation of national standards bodies (ISO member bodies). The work of preparing International Standards is normally carried out through ISO technical committees. Each member body interested in a subject for which a technical committee has been established has the right to be represented on that committee. International organizations, governmental and non-governmental, in liaison with ISO, also take part in the work. ISO collaborates closely with the International Electrotechnical Commission (IEC) on all matters of electrotechnical standardization.

The procedures used to develop this document and those intended for its further maintenance are described in the ISO/IEC Directives, Part 1. In particular, the different approval criteria needed for the different types of ISO documents should be noted. This document was drafted in accordance with the editorial rules of the ISO/IEC Directives, Part 2 (see [www.iso.org/directives](http://www.iso.org/directives)).

ISO draws attention to the possibility that the implementation of this document may involve the use of (a) patent(s). ISO takes no position concerning the evidence, validity or applicability of any claimed patent rights in respect thereof. As of the date of publication of this document, ISO [had/had not] received notice of (a) patent(s) which may be required to implement this document. However, implementers are cautioned that this may not represent the latest information, which may be obtained from the patent database available at [www.iso.org/patents](http://www.iso.org/patents). ISO shall not be held responsible for identifying any or all such patent rights.

Any trade name used in this document is information given for the convenience of users and does not constitute an endorsement.

For an explanation of the voluntary nature of standards, the meaning of ISO specific terms and expressions related to conformity assessment, as well as information about ISO's adherence to the World Trade Organization (WTO) principles in the Technical Barriers to Trade (TBT), see [www.iso.org/iso/foreword.html](http://www.iso.org/iso/foreword.html).

This document was prepared by Technical Committee ISO/TC 205, *Building environment design*.

A list of all parts in the ISO 16484 series can be found on the ISO website.

Any feedback or questions on this document should be directed to the user's national standards body. A complete listing of these bodies can be found at [www.iso.org/members.html](http://www.iso.org/members.html).



## Introduction

Buildings are built and operated serving a specific purpose, e.g. as an office workspace, a manufacturing floor, or a data centre. In each case, the usage of the space requires specific environmental conditions, e.g. temperature, light level or air quality, which is provided.

Increasing the efficient usage of energy to provide these environmental conditions is a key aspect of building design addressed in EN ISO 52120-1, *Energy Performance of Buildings — Energy performance of buildings — Part 1: Impact of Building Automation, Controls and Building Management*.

Energy efficiency requirements cannot be fulfilled by optimizing the primary systems of a building alone. A holistic view on the building and especially on the room control systems for lighting, solar protection and HVAC is the basis for optimizing the energy efficiency of buildings. This requires integration of the room and building controls and management systems from the design phase through installation and commissioning to the building operation.

The planning process for the technical infrastructure of a building and its spaces includes several steps starting with a rough set of requirements. With each step in the planning process the design becomes more detailed. First basic design choices or decisions allow for a budget estimate. These first design choices may be documented as depicted in [Figure 1](#).

# iTeh Standards (<https://standards.iteh.ai>) Document Preview

[oSIST prEN ISO 16484-4:2024](https://standards.iteh.ai/catalog/standards/sist/afaddc45-4d54-4424-86d2-f270d6021e33/osist-pren-iso-16484-4-2024)

<https://standards.iteh.ai/catalog/standards/sist/afaddc45-4d54-4424-86d2-f270d6021e33/osist-pren-iso-16484-4-2024>

## ISO/DIS 16484-4:2023(E)

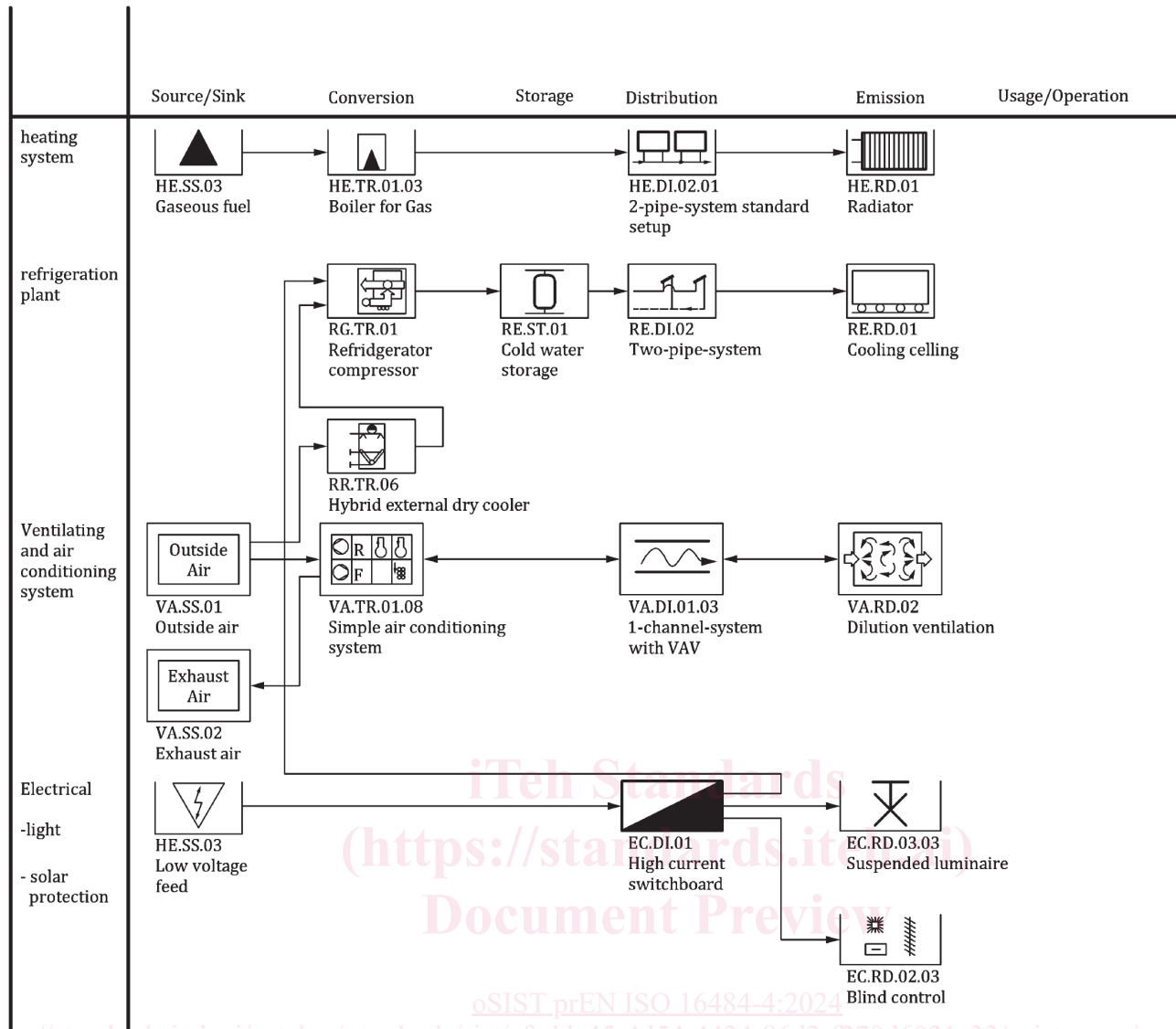

**Figure 1 — Example for documentation of design choices for technical infrastructure of a building (Source: SN 502411:2016 / SIA 411:2016)**

Figure 1 shows the equipment required for the different technical building disciplines (heating, cooling, ventilation, lighting, solar protection) in the space including energy related interconnections between the equipment of the respective disciplines. The schema depicts source/sink, conversion, storage, distribution, and emission elements and their interconnections in a simple manner. This is a high-level view on the mechanical and electrical equipment. It does not yet include the automation requirements associated with the equipment.

In a further planning step, the control functions (BAC functions) associated with the technical infrastructure equipment of a building are added as depicted in Figure 2.

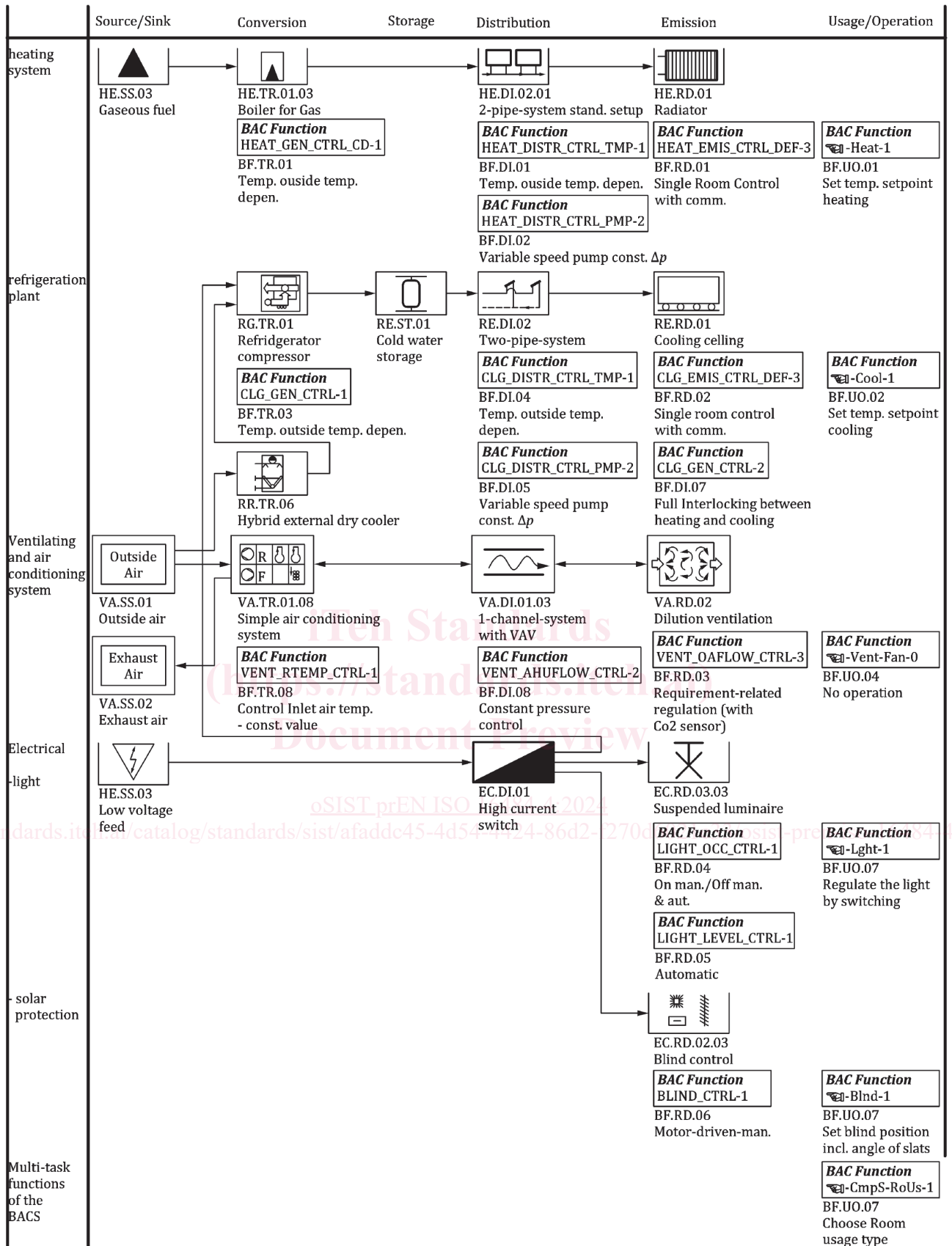

Figure 2 — Example for documentation of design choices for technical infrastructure and associated control functions of a building (Source: SN 502411:2016 / SIA 411:2016)

## ISO/DIS 16484-4:2023(E)

The column “usage/operation” contains control functions required for user interaction with the technical building infrastructure in the space and/or for super-ordinated (e.g. building-wide) functions and requirements.

Whereas the control functions are determined by the technical building equipment and the user operation interface in general, the sophistication of these control functions is determined by the desired level of energy efficiency of a building or comfort and operational requirements. Hence, both views, the desired level of energy efficiency of a building and the comfort and operational requirements, are considered and documented such that this documentation serves as a requirement specification for building control applications (heating, cooling, ventilation, lighting, solar protection) in a space.

In [Figure 2](#), BAC functions have been added to the equipment. The labels refer to BAC functions listed in EN ISO 52120-1:2022, Table 5. These BAC functions are not specified in detail in EN ISO 52120-1.

[Clause 5](#) of this document provides a method to transfer energy performance, comfort, and operational requirements as defined in EN ISO 52120-1:2022 into a more detailed specification of building automation functions.

Refer to EN ISO 52120-1:2022, Table 5, for a list of functions contributing to achieve the desired level of energy performance. Whereas EN ISO 52120-1:2022 only provides a very brief description of the functionality, [Clause 5](#) contains a more detailed description.

NOTE Application of automated control improves the energy performance of buildings. [Clause 5](#) of this document covers automated control applications only. Any manual or non-automated control listed in EN ISO 52120-1:2022, Table 5, is not covered in this document.

For the purpose of clarity, each subclause in [Clause 5](#) contains a reference in square brackets to the corresponding entry in Table 5 of EN ISO 52120-1:2022 directly after the sub-clause heading.

The more detailed description includes information about mandatory and optional inputs as well as mandatory and optional outputs for the control function. The control function is not described in detail but rather is a “black box” as the actual implementation may be project or manufacturer specific.

[Figure 3](#) provides an informative schematic view with the function (box), mandatory (blue) and optional (grey) inputs and mandatory (blue) and optional (grey) outputs. The informative schematic drawing also shows if inputs may be controlled, e.g. by manual operation or by a schedule and if output values are associated e.g. with an alarm or a trend.

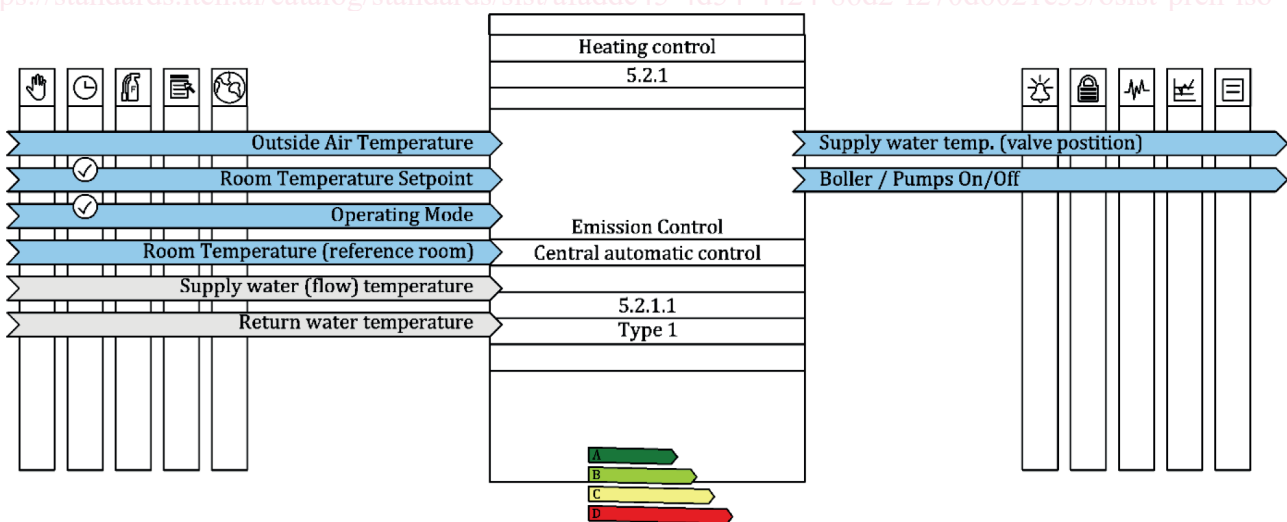

**Figure 3 — Informative depiction of control application scheme for Heating control - Emission control - Type 1: Central automatic control**

[Clause 5](#) contains in each sub-clause a brief description of the control function itself, the target of the function, different operating modes, where applicable, and a description of the inputs and outputs of the function. Optionally, parameters and implementation equipment may be described.

For some of these functions more than one version is described, covering different technological implementations.

Building control functions may be associated with a specific zone, a room, a building segment, or the whole building.

The result of applying [Clause 5](#) is a collection of building automation control function blocks. This does not yet depict how these blocks work in detail or how they are linked to each other. A more detailed control scheme description can be provided using the function blocks described in [Clause 6](#).

[Clause 6](#) of this document provides function blocks, which can be used to describe building control functions in more detail independent of a specific building control system or vendor.

Applications can be described by a combination of sensor input, actuator output, user interaction, and control and monitoring functions. Certain functions in a room (e.g. presence detection) may be shared by two or more applications. A common set of function blocks covering sensor input, actuator output, user interaction, and control functions for the different applications in a room serves as the basis for describing room automation, controls and management systems.

Using a typical example, [Figure 4](#) shows the relationship between sensor, display/operation, control and actuator functions. Information exchanged between functions is provided from outputs to inputs. Physical inputs and outputs associated with Sensor and Actuator functions are not depicted in the figure. As some functions may require parameters these are also depicted in each function block.

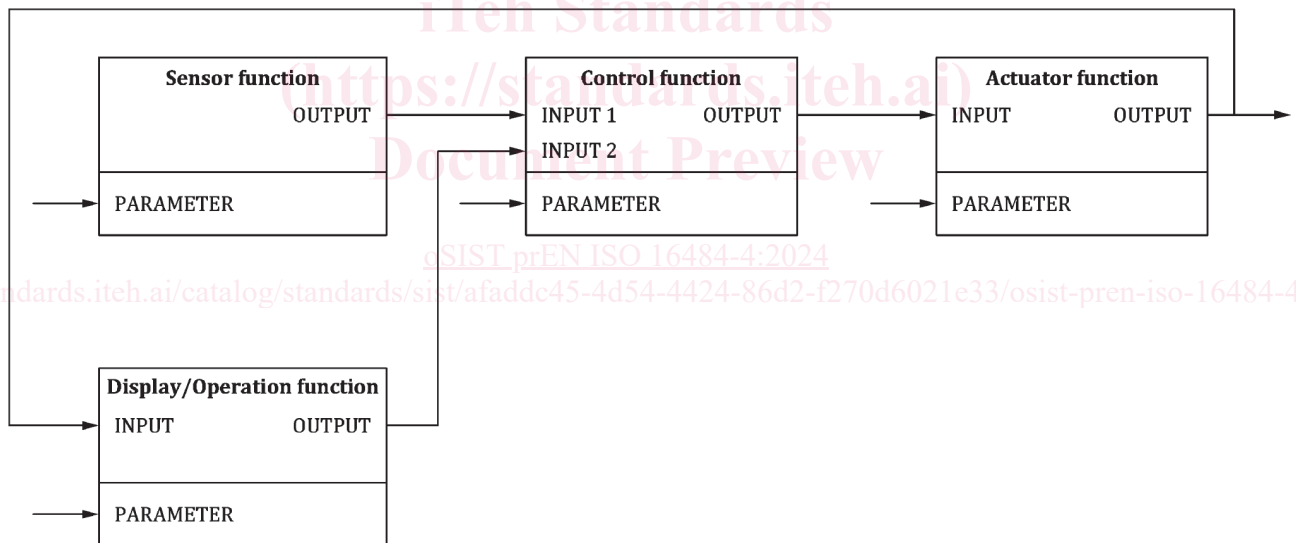

**Figure 4 — Relationship between Automation functions (typical example)**

A sensor function typically includes a physical input (e.g. a temperature sensor, not depicted in [Figure 4](#)) and provides a logical output (OUTPUT of the Sensor function block in [Figure 4](#)) for use by other functions.

A display and operation function includes physical inputs or outputs depending on its functionality and provides logical inputs for display purposes and logical outputs for use by other functions (Display and Operation function block in [Figure 4](#)).

Control functionality as depicted in [Figure 4](#) is assigned to specific control functions with one or more logical inputs (INPUT 1 and INPUT 2 of the Control function block in [Figure 4](#)) and at least one logical

## ISO/DIS 16484-4:2023(E)

output (OUTPUT of the Control function block in [Figure 4](#)). Control functions are not directly associated with physical inputs or outputs.

Actuator functionality is assigned to specific actuator functions. An actuator function typically includes a physical output (controlling e.g. a valve) and provides a logical input (INPUT of the Actuator function in [Figure 4](#)) and logical output. This logical output could be used as a feedback status information.

The generalized description format used in [Clause 6](#) for functions includes a brief description of the function, of the physical input(s), of the logical input(s) expected from other functions, of the logical output(s) provided to other functions, and of the physical output(s). In addition, parameters are listed that are required to more precisely define the function for a specific project.

The description of the functions blocks follows this uniform scheme:

- Short description of the function;
- Physical Input(s);
- Logical Input(s);
- Logical Output(s);
- Physical Output(s);
- Parameters (optional).

The list of functions may be extended where necessary.

# iTeh Standards (<https://standards.iteh.ai>) Document Preview

[oSIST prEN ISO 16484-4:2024](https://standards.iteh.ai/catalog/standards/sist/afaddc45-4d54-4424-86d2-f270d6021e33/osist-pren-iso-16484-4-2024)

<https://standards.iteh.ai/catalog/standards/sist/afaddc45-4d54-4424-86d2-f270d6021e33/osist-pren-iso-16484-4-2024>