



## Standard Practice for Reducing Samples of Aggregate to Testing Size<sup>1</sup>

This standard is issued under the fixed designation C702/C702M; the number immediately following the designation indicates the year of original adoption or, in the case of revision, the year of last revision. A number in parentheses indicates the year of last reapproval. A superscript epsilon ( $\epsilon$ ) indicates an editorial change since the last revision or reapproval.

*This standard has been approved for use by agencies of the Department of Defense.*

### 1. Scope

1.1 This practice covers three methods for the reduction of large samples of aggregate to the appropriate size for testing employing techniques that are intended to minimize variations in measured characteristics between the test samples so selected and the large sample.

~~1.2 The values stated in SI units are to be regarded as the standard.~~

1.2 The values stated in either SI units or inch-pound units are to be regarded separately as standard. The values stated in each system may not be exact equivalents; therefore, each system shall be used independently of the other. Combining values from the two systems may result in non-conformance with the standard.

NOTE 1—Sieve size is identified by its standard designation in Specification E11. The alternative designation given in parentheses is for information only and does not represent a different standard sieve size.

1.3 *This standard does not purport to address all of the safety concerns, if any, associated with its use. It is the responsibility of the user of this standard to establish appropriate safety and health practices and determine the applicability of regulatory limitations prior to use.*

### 2. Referenced Documents

2.1 *ASTM Standards:*<sup>2</sup>

C125 [Terminology Relating to Concrete and Concrete Aggregates](#)

C128 [Test Method for Density, Relative Density \(Specific Gravity\), and Absorption of Fine Aggregate](#)

~~D75 [Practice for Sampling Aggregates](#)~~ [Practice for Sampling Aggregates](#)

E11 [Specification for Woven Wire Test Sieve Cloth and Test Sieves](#)

### 3. Terminology

3.1 *Definitions*—The terms used in this practice are defined in Terminology C125.

### 4. Significance and Use

4.1 Specifications for aggregates require sampling portions of the material for testing. Other factors being equal, larger samples will tend to be more representative of the total supply. This practice provides procedures for reducing the large sample obtained in the field or produced in the laboratory to a convenient size for conducting a number of tests to describe the material and measure its quality in a manner that the smaller test sample portion is most likely to be a representation of the larger sample, and thus of the total supply. Failure to carefully follow the procedures in this practice could result in providing a nonrepresentative sample to be used in subsequent testing. The individual test methods provide for minimum amount of material to be tested.

4.2 Under certain circumstances, reduction in size of the large sample prior to testing is not recommended. Substantial differences between the selected test samples sometimes cannot be avoided, as for example, in the case of an aggregate having relatively few large size particles in the sample. The laws of chance dictate that these few particles may be unequally distributed among the reduced size test samples. Similarly, if the test sample is being examined for certain contaminants occurring as a few discrete fragments in only small percentages, caution should be used in interpreting results from the reduced size test sample.

<sup>1</sup> This practice is under the jurisdiction of ASTM Committee C09 on Concrete and Concrete Aggregates and is the direct responsibility of Subcommittee C09.20 on Normal Weight Aggregates.

~~Current edition approved June 10, 2003. Published July 2003. Originally approved in 1971. Last previous edition approved in 1998 as C702-98. DOI: 10.1520/C0702-98R03.~~

Current edition approved Aug. 1, 2011. Published September 2011. Originally approved in 1971. Last previous edition approved in 2003 as C702-98(2003). DOI: 10.1520/C0702\_C0702M-11.

<sup>2</sup> For referenced ASTM standards, visit the ASTM website, [www.astm.org](http://www.astm.org), or contact ASTM Customer Service at [service@astm.org](mailto:service@astm.org). For *Annual Book of ASTM Standards* volume information, refer to the standard's Document Summary page on the ASTM website.

Chance inclusion or exclusion of only one or two particles in the selected test sample may importantly influence interpretation of the characteristics of the original sample. In these cases, the entire original sample should be tested.

## 5. Selection of Method

5.1 *Fine Aggregate*—Reduce the size of samples of fine aggregate that are drier than the saturated-surface-dry condition (Note 1 and Note 2) using a mechanical splitter according to Method A. Reduce the size of samples having free moisture on the particle surfaces by quartering according to Method B, or by treating as a miniature stockpile as described in Method C.

5.1.1 If the use of Method B or Method C is desired, and the sample does not have free moisture on the particle surfaces, moisten the sample to obtain free moisture on the particle surfaces, mix thoroughly, and then reduce the sample size.

5.1.2 If use of Method A is desired and the sample has free moisture on the particle surfaces, dry the entire sample to at least the saturated-surface-dry condition, using temperatures that do not exceed those specified for any of the tests contemplated, and then reduce the sample size. Alternatively, if the moist sample is very large, make a preliminary split using a mechanical splitter having chute openings of 38 mm (1½ in.) or more in width to reduce the sample to not less than 5000 g (5 kg [10 lb]). Dry the portion so obtained, and reduce it to test sample size using Method A.

NOTE 1—The method of determining the saturated-surface-dry condition is described in Test Method C128. As a quick approximation, if the fine aggregate will retain its shape when molded in the hand, it may be considered to be wetter than saturated-surface-dry.

5.2 *Coarse Aggregates and Mixtures of Coarse and Fine Aggregates*—Reduce the sample using a mechanical splitter in accordance with Method A (preferred method) or by quartering in accordance with Method B. The miniature stockpile Method C is not permitted for coarse aggregates or mixtures of coarse and fine aggregates.

## 6. Sampling

6.1 Obtain samples of aggregate in the field in accordance with Practice D75, or as required by individual test methods. When tests for sieve analysis only are contemplated, the size of the field sample listed in Practice D75 is usually adequate. When additional tests are to be conducted, the user shall be satisfied that the initial size of the field sample is adequate to accomplish all intended tests. Use similar procedures for aggregate produced in the laboratory.

### METHOD A—MECHANICAL SPLITTER

## 7. Apparatus

7.1 *Sample Splitter*—Sample splitters shall have an even number of equal width chutes, but not less than a total of eight for coarse aggregate, or twelve for fine aggregate, which discharge alternately to each side of the splitter. For coarse aggregate and mixed aggregate, the minimum width of the individual chutes shall be approximately 50 % larger than the largest particles in the sample to be split (Note 2 and Note 3). For dry fine aggregate in which the entire sample will pass the 9.5-mm (¾-in.) sieve, a splitter having chutes 12.5 to 20 mm (½ to ¾ in.) wide shall be used. The splitter shall be equipped with two receptacles to hold the two halves of the sample following splitting. It shall also be equipped with a hopper or straightedged pan which has a width equal to or slightly less than the over-all width of the assembly of chutes, by which the sample may be fed at a controlled rate to the chutes. The splitter and accessory equipment shall be so designed that the sample will flow smoothly without restriction or loss of material (see Fig. 1 and Fig. 2).

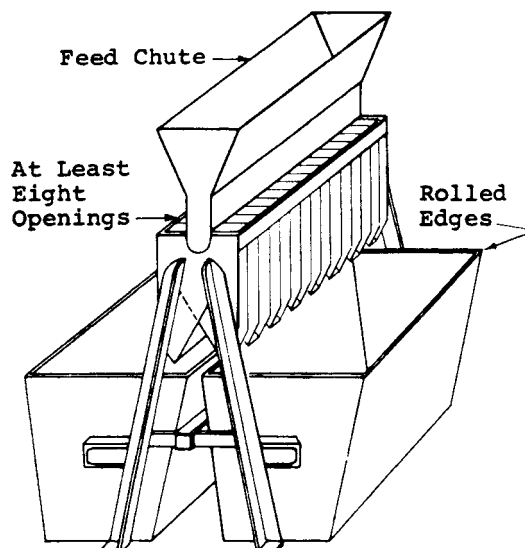

FIG. 1 Large Sample Splitter for Coarse Aggregate