



**International
Standard**

ISO 12164-6

**Hollow taper interface with flange
contact surface —**

**Part 6:
Receivers of types AS, CS and ES for
hollow taper shanks of types AS,
CS and ES**

Interfaces à cône creux-face —

*Partie 6: Nez de broches de types AS, CS et ES pour queues de
types AS, CS et ES*

**First edition
2023-10**

**Corrected version
2024-09**

Document Preview

iTeh Standards
(<https://standards.iteh.ai>)
Document Preview

[ISO 12164-6:2023](https://standards.iteh.ai/catalog/standards/iso/b75b4edd-3a43-4511-89a6-1a9b3d852aa4/iso-12164-6-2023)

<https://standards.iteh.ai/catalog/standards/iso/b75b4edd-3a43-4511-89a6-1a9b3d852aa4/iso-12164-6-2023>



COPYRIGHT PROTECTED DOCUMENT

© ISO 2023

All rights reserved. Unless otherwise specified, or required in the context of its implementation, no part of this publication may be reproduced or utilized otherwise in any form or by any means, electronic or mechanical, including photocopying, or posting on the internet or an intranet, without prior written permission. Permission can be requested from either ISO at the address below or ISO's member body in the country of the requester.

ISO copyright office
CP 401 • Ch. de Blandonnet 8
CH-1214 Vernier, Geneva
Phone: +41 22 749 01 11
Email: copyright@iso.org
Website: www.iso.org

Published in Switzerland

Contents

| | Page |
|--|-----------|
| Foreword | iv |
| 1 Scope | 1 |
| 2 Normative references | 1 |
| 3 Terms and definitions | 1 |
| 4 Receivers for hollow taper shanks, types and dimensions | 1 |
| 4.1 General..... | 1 |
| 4.2 Receiver of type AS for hollow taper shanks of type AS..... | 2 |
| 4.3 Receiver of type CS for hollow taper shanks of type CS..... | 3 |
| 4.4 Receiver of type ES for hollow taper shanks of type ES..... | 4 |
| 4.5 Dimensions..... | 5 |
| 5 Design | 6 |
| 5.1 HSK Sizes and types..... | 6 |
| 5.2 Material and heat treatment..... | 6 |
| 6 Designation | 6 |
| Annex A (informative) Recommendations for use and application | 7 |
| Bibliography | 8 |

iTeh Standards
(<https://standards.itih.ai>)
Document Preview

[ISO 12164-6:2023](https://standards.itih.ai/catalog/standards/iso/b75b4edd-3a43-4511-89a6-1a9b3d852aa4/iso-12164-6-2023)

<https://standards.itih.ai/catalog/standards/iso/b75b4edd-3a43-4511-89a6-1a9b3d852aa4/iso-12164-6-2023>

Foreword

ISO (the International Organization for Standardization) is a worldwide federation of national standards bodies (ISO member bodies). The work of preparing International Standards is normally carried out through ISO technical committees. Each member body interested in a subject for which a technical committee has been established has the right to be represented on that committee. International organizations, governmental and non-governmental, in liaison with ISO, also take part in the work. ISO collaborates closely with the International Electrotechnical Commission (IEC) on all matters of electrotechnical standardization.

The procedures used to develop this document and those intended for its further maintenance are described in the ISO/IEC Directives, Part 1. In particular, the different approval criteria needed for the different types of ISO document should be noted. This document was drafted in accordance with the editorial rules of the ISO/IEC Directives, Part 2 (see www.iso.org/directives).

ISO draws attention to the possibility that the implementation of this document may involve the use of (a) patent(s). ISO takes no position concerning the evidence, validity or applicability of any claimed patent rights in respect thereof. As of the date of publication of this document, ISO had not received notice of (a) patent(s) which may be required to implement this document. However, implementers are cautioned that this may not represent the latest information, which may be obtained from the patent database available at www.iso.org/patents. ISO shall not be held responsible for identifying any or all such patent rights.

Any trade name used in this document is information given for the convenience of users and does not constitute an endorsement.

For an explanation of the voluntary nature of standards, the meaning of ISO specific terms and expressions related to conformity assessment, as well as information about ISO's adherence to the World Trade Organization (WTO) principles in the Technical Barriers to Trade (TBT), see www.iso.org/iso/foreword.html.

This document was prepared by Technical Committee ISO/TC 29, *Small tools*, Subcommittee SC 9, *Tools with defined cutting edges, holding tools, cutting items, adaptive items and interfaces*.

A list of all parts of the ISO 12164 series can be found on the ISO website.

Any feedback or questions on this document should be directed to the user's national standards body. A complete listing of these bodies can be found at www.iso.org/members.html.

This corrected version of ISO 12164-6:2023 incorporates the following corrections:

- in 5.2 the minimum hardness value, 50 HRC, has been changed to 60 HRC;
- in Table A.1 columns for nominal size 25 and 32 were removed.

Hollow taper interface with flange contact surface —

Part 6:

Receivers of types AS, CS and ES for hollow taper shanks of types AS, CS and ES

1 Scope

This document specifies dimensions for receivers with taper and flange contact surfaces for hollow taper shanks (HSK) in accordance with ISO 12164-5 to be applied to machine tools (e.g. machines for turning, drilling, milling and grinding).

This document specifies three types of receivers:

- type AS for automatic tool change;
- type CS for manual tool change only, via radial holes in both the receiver and the tool shank;
- type ES for automatic tool change.

NOTE 1 The receivers of types AS, CS and ES fit the HSK shanks of types AS, CS and ES (according to ISO 12164-5).

NOTE 2 HSK shanks of types AS and ES can also be changed manually.

2 Normative references

The following documents are referred to in the text in such a way that some or all of their content constitutes requirements of this document. For dated references, only the edition cited applies. For undated references, the latest edition of the referenced document (including any amendments) applies.

ISO 2768-1, *General tolerances — Part 1: Tolerances for linear and angular dimensions without individual tolerance indications*

3 Terms and definitions

No terms and definitions are listed in this document.

ISO and IEC maintain terminology databases for use in standardization at the following addresses:

- ISO Online browsing platform: available at <https://www.iso.org/obp>
- IEC Electropedia: available at <https://www.electropedia.org/>

4 Receivers for hollow taper shanks, types and dimensions

4.1 General

Dimensions of receivers for hollow taper shanks with flange contact surface of types AS, CS and ES are specified in [Figures 1 to 3](#) and in [Table 1](#). Details not specified shall be chosen expediently. Tolerances of form, orientation, location and run-out correspond to ISO 1101. Dimensions and tolerances of cones are in

ISO 12164-6:2023(en)

according to ISO 3040. Tolerances not specified shall be of tolerance class “m” in accordance with ISO 2768-1. Recommendations for use and application are provided in [Annex A](#).

4.2 Receiver of type AS for hollow taper shanks of type AS

The dimensions of a receiver for hollow taper shanks of type AS shall be in accordance with [Figure 1](#) and [Table 1](#).

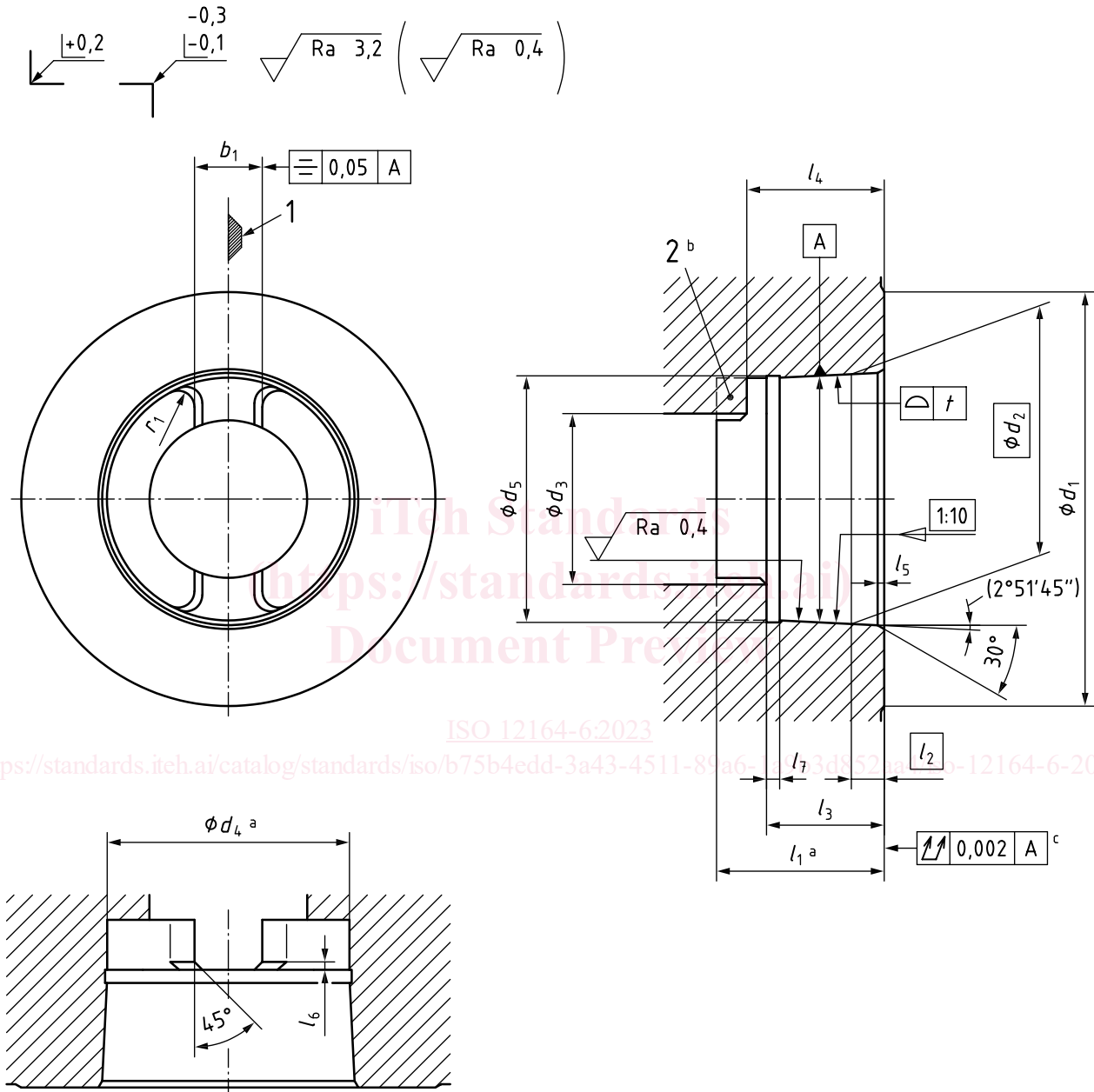

Key

- 1 position of the cutting edge for right hand tools with single cutting edge
- 2 tenon block
- a With inserted tenon blocks, the taper may extend over the total depth l_1 .
- b Tenon blocks, either integrated or inserted.
- c Not convex.

Figure 1 — Receiver of type AS for hollow taper shanks of type AS