

ISO/FDIS 3611:~~2022~~ **2023**(E)

Third edition

Date: ~~2022-11-15~~ **2023-01-24**

ISO/TC 213/WG 6

Secretariat: BSI

Geometrical product specifications (GPS) — Dimensional measuring equipment — Design and metrological characteristics of micrometers for external measurements

Spécification géométrique des produits (GPS) — Équipement de mesurage dimensionnel: Micromètres d'extérieur — Caractéristiques de conception et caractéristiques métrologiques

(standards.iteh.ai)

ISO/FDIS 3611

<https://standards.iteh.ai/catalog/standards/sist/fbd90cb9-6728-4f09-a166-786ad17dba98/iso-fdis-3611>

© ISO 2023

All rights reserved. Unless otherwise specified, or required in the context of its implementation, no part of this publication may be reproduced or utilized otherwise in any form or by any means, electronic or mechanical, including photocopying, or posting on the internet or an intranet, without prior written permission. Permission can be requested from either ISO at the address below or ISO's member body in the country of the requester.

ISO Copyright Office

CP 401 • CH-1214 Vernier, Geneva

Phone: + 41 22 749 01 11

Email: copyright@iso.org

Website: www.iso.org

Published in Switzerland.

iTeh STANDARD PREVIEW
(standards.iteh.ai)

[ISO/FDIS 3611](https://standards.iteh.ai/catalog/standards/sist/fbd90cb9-6728-4f09-a166-786ad17dba98/iso-fdis-3611)

<https://standards.iteh.ai/catalog/standards/sist/fbd90cb9-6728-4f09-a166-786ad17dba98/iso-fdis-3611>

Contents	Page
Foreword.....	iv
Introduction.....	v
1 Scope	1
2 Normative references	1
3 Terms and definitions.....	2
4 Design characteristics.....	2
4.1 General design and nomenclature	2
4.2 Dimensions	3
4.3 Types of indicating device	4
4.3.1 General	4
4.3.2 Analogue indicating devices	4
4.3.3 Digital indicating devices.....	5
4.4 Frame	5
4.5 Measuring force limiting device.....	5
5 Metrological characteristics	7
5.1 General	7
5.2 Rated operating conditions.....	7
5.3 Reference point	7
5.4 Test methods.....	7
5.5 Length measurement error, E (limited by E_{MPE}).....	8
5.5.1 General	8
5.5.2 Test point selection.....	8
5.6 Variation in length measurement error, V (limited by V_{MPE}).....	8
5.6.1 General	8
5.6.2 Number of tests	8
5.6.3 Testing with optical parallels.....	9
5.7 Measuring forces.....	9
5.8 Specifications	9
5.8.1 General	9
5.8.2 Classification system	9
6 Determination of conformity to specifications.....	12
6.1 General	12
6.2 Measurement uncertainty	12
6.3 Decision rule.....	12
7 Marking	12
Annex A (informative) Calibration guidelines for metrological characteristics	13
Annex B (informative) Notes on use	14
Annex C (informative) Relation to the GPS matrix model.....	15
Bibliography	17

Foreword

ISO (the International Organization for Standardization) is a worldwide federation of national standards bodies (ISO member bodies). The work of preparing International Standards is normally carried out through ISO technical committees. Each member body interested in a subject for which a technical committee has been established has the right to be represented on that committee. International organizations, governmental and non-governmental, in liaison with ISO, also take part in the work. ISO collaborates closely with the International Electrotechnical Commission (IEC) on all matters of electrotechnical standardization.

The procedures used to develop this document and those intended for its further maintenance are described in the ISO/IEC Directives, Part 1. In particular, the different approval criteria needed for the different types of ISO documents should be noted. This document was drafted in accordance with the editorial rules of the ISO/IEC Directives, Part 2 (see www.iso.org/directives).

Attention is drawn to the possibility that some of the elements of this document may be the subject of patent rights. ISO shall not be held responsible for identifying any or all such patent rights. Details of any patent rights identified during the development of the document will be in the Introduction and/or on the ISO list of patent declarations received (see www.iso.org/patents).

Any trade name used in this document is information given for the convenience of users and does not constitute an endorsement.

For an explanation of the voluntary nature of standards, the meaning of ISO specific terms and expressions related to conformity assessment, as well as information about ISO's adherence to the World Trade Organization (WTO) principles in the Technical Barriers to Trade (TBT), see www.iso.org/iso/foreword.html.

This document was prepared by Technical Committee ISO/TC 213, *Dimensional and geometrical product specifications and verification*, in collaboration with the European Committee for Standardization (CEN) Technical Committee CEN/TC 290, *Dimensional and geometrical product specification and verification*, in accordance with the Agreement on technical cooperation between ISO and CEN (Vienna Agreement).

This third edition cancels and replaces the second edition (ISO 3611:2010), which has been technically revised.

The main changes are as follows:

- general design characteristics have been removed and reference to ISO 14978:2018 has been included;
- metrological characteristics have been clarified and modified;
- requirements for test methods have been included;
- classification system of maximum permissible errors has been added.

Any feedback or questions on this document should be directed to the user's national standards body. A complete listing of these bodies can be found at www.iso.org/members.html.

Introduction

This document is a geometrical product specification (GPS) standard and is to be regarded as a general GPS standard (see ISO 14638). It influences the chain links for measuring equipment and calibration on size and distance in the general GPS matrix (see Annex C).

The ISO GPS Masterplan given in ISO 14638 gives an overview of the ISO GPS system of which this document is a part. The fundamental rules of ISO GPS given in ISO 8015 apply to this document and the default decision rules given in ISO 14253-1 apply to specifications made in accordance with this document, unless otherwise indicated; see ISO/TR 14253-6 for additional information on the selection of alternative decision rules.

For more detailed information on the relation of this document to other standards and the GPS matrix model, see Annex C.

iTeh STANDARD PREVIEW
(standards.iteh.ai)

ISO/FDIS 3611

<https://standards.iteh.ai/catalog/standards/sist/fbd90cb9-6728-4f09-a166-786ad17dba98/iso-fdis-3611>

Geometrical product specifications (GPS) — Dimensional measuring equipment — Design and metrological characteristics of micrometers for external measurements

1 Scope

This document provides the most important design and metrological characteristics of micrometers for external measurements:

- with analogue indication;
- with digital indication: mechanical or electronic digital display.

2 Normative references

The following documents are referred to in the text in such a way that some or all of their content constitutes requirements of this document. For dated references, only the edition cited applies. For undated references, the latest edition of the referenced document (including any amendments) applies.

~~ISO 3650, Geometrical product specifications (GPS) — Length standards — Gauge blocks~~

ISO 14253-1, *Geometrical product specifications (GPS) — Inspection by measurement of workpieces and measuring equipment — Part 1: Decision rules for verifying conformity or nonconformity with specifications*

ISO 14253-5, *Geometrical product specifications (GPS) — Inspection by measurement of workpieces and measuring equipment — Part 5: Uncertainty in verification testing of indicating measuring instruments*

ISO/TR 14253-6, *Geometrical product specifications (GPS) — Inspection by measurement of workpieces and measuring equipment — Part 6: Generalized decision rules for the acceptance and rejection of instruments and workpieces*

ISO 14978:2018, *Geometrical product specifications (GPS) — General concepts and requirements for GPS measuring equipment*

ISO/IEC Guide 98-3, *Uncertainty of measurement — Part 3: Guide to the expression of uncertainty in measurement (GUM:1995)*

ISO/IEC Guide 99, *International vocabulary of metrology — Basic and general concepts and associated terms (VIM)*

3 Terms and definitions

For the purposes of this document, the terms and definitions given in ISO 14978 ~~and~~, ISO/IEC Guide 99 and the following apply.

ISO and IEC maintain terminology databases for use in standardization at the following addresses:

- ISO Online browsing platform: available at <https://www.iso.org/obp>
- IEC Electropedia: available at <https://www.electropedia.org/>

3.1 micrometer for external measurements
measuring instrument which gives the evaluation of a dimensional quantity of an external feature of a workpiece on the basis of movement of a spindle with a measuring face, moving relatively to a material measure and an anvil, with the movement generated by a screw thread

Note 1 to entry: The guiding elements of the spindle and of the anvil are connected by a frame.

Note 2 to entry: Usually, micrometers for external measurements have a thread as a material measure with the anvil, spindle and material measure arranged in a line.

3.2 measuring face contact
contact between the measuring face and an integral feature of a workpiece

3.3 full measuring face contact
contact between the full area of the measuring face and an integral feature of a workpiece

3.4 partial measuring face contact
contact between a partial area of the measuring face and an integral feature of a workpiece

4 Design characteristics

4.1 General design and nomenclature

The design of a micrometer for external measurements shall follow the general guidelines in ISO 14978, including the common design characteristics in ~~Annex C of~~ ISO 14978:2018, Annex C. See Figure 1 for an example of the general design.

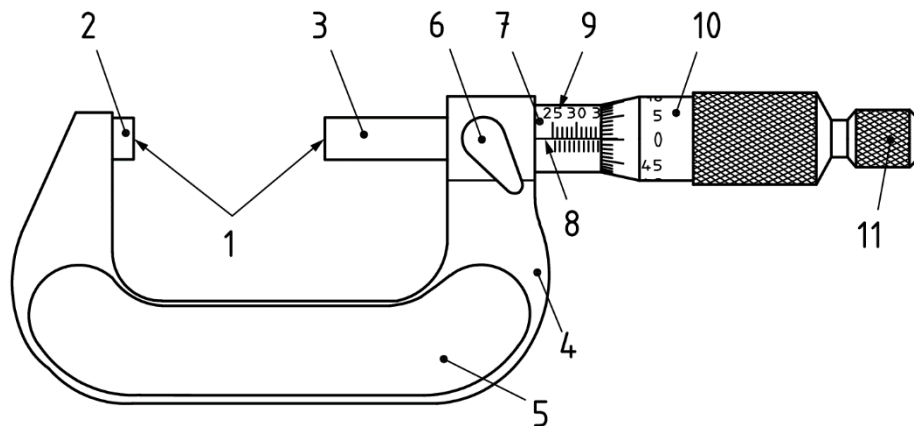

Key

- | | | | |
|---|----------------------------|----|---------------------|
| 1 | measuring faces | 7 | sleeve |
| 2 | anvil | 8 | fiducial line |
| 3 | measuring spindle | 9 | analogue indication |
| 4 | frame | 10 | thimble |
| 5 | thermally insulating plate | 11 | fast drive |
| 6 | spindle clamp | | |

Figure 1 — Nomenclature and general design of a micrometer for external measurements

4.2 Dimensions

The manufacturer shall state important dimensions, such as those shown in Figure 2 and Table 1. The values shown in Table 1 are typical dimensions and are not requirements of this document.

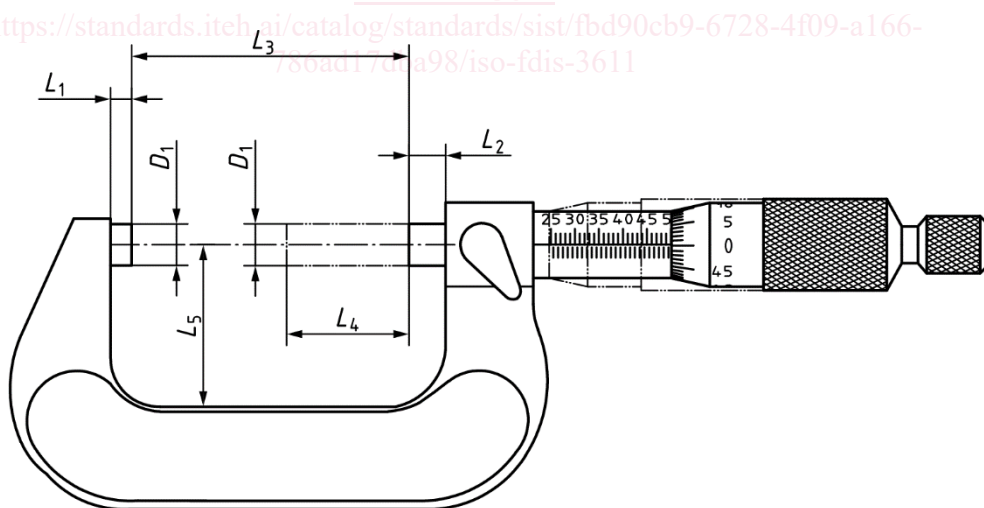

Figure 2 — Dimensions of a micrometer for external measurements

Table 1 — Dimensions of a micrometer for external measurements

Dimension	Nominal value
Anvil length, L_1	
Spindle length at maximum position, L_2	
Maximum dimension measurable, L_3	
Measuring span, L_4	25 mm ^a
Frame depth, L_5^b	
Spindle and anvil diameter, D_1	
<p>NOTE The dimensions D_1, L_1 and L_2 are important for the interchangeability of accessories mounted on the measuring faces.</p> <p>^a Usually, the measuring span L_4 is 25 mm. Other measuring spans are possible.</p> <p>^b Usually, the frame is shaped to permit the measurement of a cylinder whose diameter is equal to the last value of the measuring range.</p>	

4.3 Types of indicating devices

4.3.1 General

Several types of indicating devices are possible:

- analogue indicating devices;
- digital indicating devices with mechanical digital display;
- digital indicating devices with electronic digital display.

NOTE Combinations of analogue and digital indicating devices are possible.

4.3.2 Analogue indicating devices

The measuring spindle should have a pitch of 0,5 mm or 1 mm. In the case of micrometers with spindles having a pitch of 0,5 mm, the 0,5 mm graduation lines on the main scale shall be clearly distinguishable from the 1 mm graduation lines by means of their arrangement above and below the fiducial line. See Figures 3 and 4.

The secondary scale on the thimble should have a scale graduated with 50 (pitch 0,5 mm) or 100 (pitch 1 mm) graduation lines, each scale interval representing 0,01 mm. For graduations of 0,001 mm, a vernier scale can be added on the sleeve. See Figure 4.

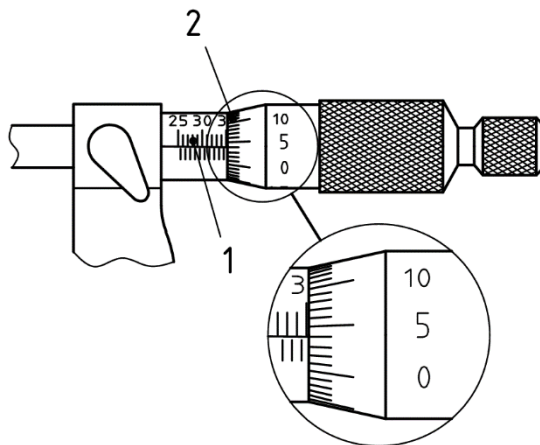

Key

- 1 main scale
- 2 secondary scale

Figure 3 — Analogue indicating device with spindle pitch of 0,5 mm

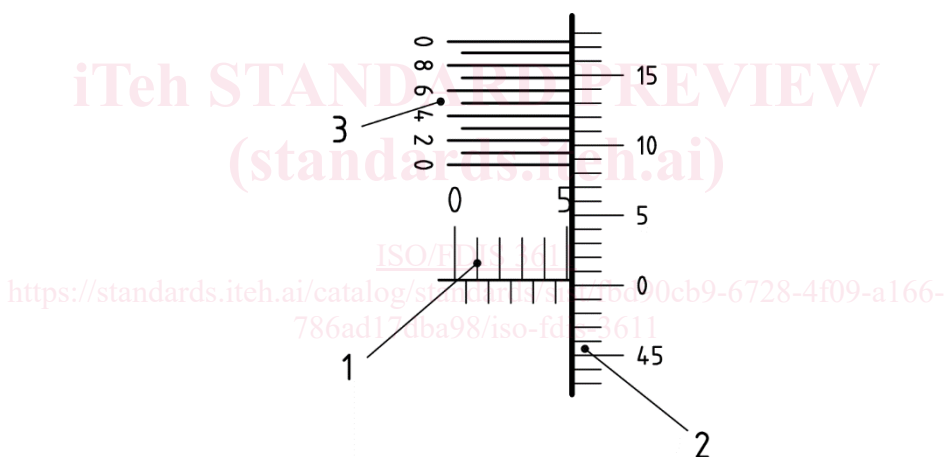

Key

- 1 main scale
- 2 secondary scale
- 3 vernier scale

Figure 4 — Analogue indicating device with spindle pitch of 0,5 mm and vernier scale interval of 0,001 mm

4.3.3 Digital indicating devices

The mechanical or electronic digital display should have a digital step of 0,01 mm or 0,001 mm.

4.4 Frame

The rigidity of the frame shall be consistent with the measuring force. For hand-held micrometers, the frame can be insulated to prevent body heat from being transmitted.

4.5 Measuring force limiting device

Each micrometer for external measurements shall be provided with a measuring force limiting device integrated in the thimble or in the fast drive.