**Friction stir welding — Aluminium —
Part 4:
Specification and qualification of
welding procedures**

Soudage par friction-malaxage — Aluminium —

Partie 4: Descriptif et qualification des modes opératoires de soudage
**iTeh STANDARD PREVIEW
(standards.iteh.ai)**

[ISO 25239-4:2020](https://standards.iteh.ai/catalog/standards/sist/cdb07390-f715-408b-b6da-ceec1af3cbef/iso-25239-4-2020)

<https://standards.iteh.ai/catalog/standards/sist/cdb07390-f715-408b-b6da-ceec1af3cbef/iso-25239-4-2020>



iTeh STANDARD PREVIEW (standards.iteh.ai)

ISO 25239-4:2020

<https://standards.iteh.ai/catalog/standards/sist/cdb07390-f715-408b-b6da-ceed1af3cbef/iso-25239-4-2020>



COPYRIGHT PROTECTED DOCUMENT

© ISO 2020

All rights reserved. Unless otherwise specified, or required in the context of its implementation, no part of this publication may be reproduced or utilized otherwise in any form or by any means, electronic or mechanical, including photocopying, or posting on the internet or an intranet, without prior written permission. Permission can be requested from either ISO at the address below or ISO's member body in the country of the requester.

ISO copyright office
CP 401 • Ch. de Blandonnet 8
CH-1214 Vernier, Geneva
Phone: +41 22 749 01 11
Email: copyright@iso.org
Website: www.iso.org

Published in Switzerland

Contents

Page

Foreword	iv
Introduction	v
1 Scope	1
2 Normative references	1
3 Terms and definitions	1
4 Development and qualification of welding procedures	2
4.1 General.....	2
4.2 Technical content of a pWPS.....	2
5 Qualification based on a welding procedure test	4
5.1 General.....	4
5.2 Test pieces.....	4
5.2.1 Shape and dimensions of test pieces.....	4
5.2.2 Welding of test pieces.....	6
5.3 Examination and testing of test pieces.....	6
5.3.1 Extent of testing.....	6
5.3.2 Visual testing and acceptance levels.....	7
5.3.3 Destructive tests.....	7
5.3.4 Re-testing.....	12
5.4 Range of qualification.....	12
5.4.1 General.....	12
5.4.2 Related to the fabricator.....	12
5.4.3 Other variables.....	12
5.5 Welding procedure qualification record.....	12
6 Qualification based on pre-production welding test	13
6.1 General.....	13
6.2 Test pieces.....	13
6.3 Examination and testing of test pieces.....	13
6.4 Range of qualification.....	13
6.5 Welding procedure qualification record.....	13
Annex A (informative) Example of a form for preliminary welding procedure specification (pWPS) and welding procedure specification (WPS)	14
Annex B (informative) Non-destructive testing	15
Annex C (informative) Hammer S-bend test of lap welds	16
Annex D (informative) Example welding procedure qualification record form (WPQR)	18
Bibliography	22

Foreword

ISO (the International Organization for Standardization) is a worldwide federation of national standards bodies (ISO member bodies). The work of preparing International Standards is normally carried out through ISO technical committees. Each member body interested in a subject for which a technical committee has been established has the right to be represented on that committee. International organizations, governmental and non-governmental, in liaison with ISO, also take part in the work. ISO collaborates closely with the International Electrotechnical Commission (IEC) on all matters of electrotechnical standardization.

The procedures used to develop this document and those intended for its further maintenance are described in the ISO/IEC Directives, Part 1. In particular, the different approval criteria needed for the different types of ISO documents should be noted. This document was drafted in accordance with the editorial rules of the ISO/IEC Directives, Part 2 (see www.iso.org/directives).

Attention is drawn to the possibility that some of the elements of this document may be the subject of patent rights. ISO shall not be held responsible for identifying any or all such patent rights. Details of any patent rights identified during the development of the document will be in the Introduction and/or on the ISO list of patent declarations received (see www.iso.org/patents).

Any trade name used in this document is information given for the convenience of users and does not constitute an endorsement.

For an explanation of the voluntary nature of standards, the meaning of ISO specific terms and expressions related to conformity assessment, as well as information about ISO's adherence to the World Trade Organization (WTO) principles in the Technical Barriers to Trade (TBT), see www.iso.org/iso/foreword.html.

This document was prepared by IIW, *International Institute of Welding*, Commission III, *Resistance Welding, Solid State Welding and Allied Joining Process*, in collaboration with the European Committee for Standardization (CEN) Technical Committee CEN/TC 121, *Welding and allied processes*, in accordance with the Agreement on technical cooperation between ISO and CEN (Vienna Agreement).

This second edition cancels and replaces the first edition (ISO 25239-4:2011), which has been technically revised.

The main changes compared to the previous edition are as follows:

- alternative process control methods (e.g. temperature control) have been included;
- the wording of the paragraph on thermal management and heat treatments has been improved;
- the definition for the extraction of test specimens has been modified for all test pieces and the figures have been revised accordingly;
- the requirement for testing transverse test specimens with as welded surfaces has been deleted;
- in [Table 3](#), a new requirement on the minimum joint efficiency has been added for heat treatable alloys below 5 mm;
- the pWPS is now to be qualified in accordance with the defined acceptance levels included in ISO 25239-5;
- acceptance levels have been included in the WPQR form in [Annex D](#).

A list of all parts in the ISO 25239 series can be found on the ISO website.

Any feedback or questions on this document should be directed to the user's national standards body. A complete listing of these bodies can be found at www.iso.org/members.html.

Introduction

Welding processes are widely used in the fabrication of engineered structures. During the second half of the twentieth century, fusion welding processes, wherein fusion is obtained by the melting of parent material and usually a filler metal, dominated the welding of large structures. In 1991, Wayne Thomas at TWI invented friction stir welding (FSW), which is carried out entirely in the solid phase (no melting).

The increasing use of FSW has created the need for this document in order to ensure that welding is carried out in the most effective way and that appropriate control is exercised over all aspects of the operation. This document focuses on the FSW of aluminium because, at the time of publication, the majority of commercial applications for FSW involved aluminium. Examples include railway carriages, consumer products, food processing equipment, aerospace structures, and marine vessels.

iTeh STANDARD PREVIEW (standards.iteh.ai)

[ISO 25239-4:2020](https://standards.iteh.ai/catalog/standards/sist/cdb07390-f715-408b-b6da-ceec1af3cbef/iso-25239-4-2020)

<https://standards.iteh.ai/catalog/standards/sist/cdb07390-f715-408b-b6da-ceec1af3cbef/iso-25239-4-2020>

iTeh STANDARD PREVIEW
(standards.iteh.ai)

ISO 25239-4:2020

<https://standards.iteh.ai/catalog/standards/sist/cdb07390-f715-408b-b6da-ceed1af3cbef/iso-25239-4-2020>

Friction stir welding — Aluminium —

Part 4: Specification and qualification of welding procedures

1 Scope

This document specifies the requirements for the specification and qualification of welding procedures for the friction stir welding (FSW) of aluminium.

In this document, the term “aluminium” refers to aluminium and its alloys.

This document does not apply to friction stir spot welding which is covered by the ISO 18785 series.

NOTE Service requirements, materials or manufacturing conditions can require more comprehensive testing than is specified in this document.

2 Normative references

The following documents are referred to in the text in such a way that some or all of their content constitutes requirements of this document. For dated references, only the edition cited applies. For undated references, the latest edition of the referenced document (including any amendments) applies.

ISO 4136, *Destructive tests on welds in metallic materials — Transverse tensile test*

ISO 5173, *Destructive tests on welds in metallic materials — Bend tests*

ISO 9017, *Destructive tests on welds in metallic materials — Fracture test*

ISO 15607:2019, *Specification and qualification of welding procedures for metallic materials — General rules*

ISO 17637, *Non-destructive testing of welds — Visual testing of fusion-welded joints*

ISO 17639, *Destructive tests on welds in metallic materials — Macroscopic and microscopic examination of welds*

ISO 25239-1, *Friction stir welding — Aluminium — Part 1: Vocabulary*

ISO 25239-5:2020, *Friction stir welding — Aluminium — Part 5: Quality and inspection requirements*

ISO/TR 25901 (all parts), *Welding and allied processes — Vocabulary*

ISO 80000-1:2009, *Quantities and units — Part 1: General*

3 Terms and definitions

For the purposes of this document, the terms and definitions given in ISO 25239-1 and ISO/TR 25901 (all parts) apply.

ISO and IEC maintain terminological databases for use in standardization at the following addresses:

- ISO Online browsing platform: available at <https://www.iso.org/obp>
- IEC Electropedia: available at <http://www.electropedia.org/>

4 Development and qualification of welding procedures

4.1 General

Qualification of welding procedures shall be performed prior to production welding.

The abbreviations listed in ISO 15607:2019, Table 1, shall apply.

The fabricator shall prepare a preliminary welding procedure specification (pWPS) and shall ensure that it is applicable for production using experience from previous production jobs and the general fund of knowledge of welding technology. The pWPS shall be prepared with the aim of achieving the required quality acceptance levels specified in ISO 25239-5:2020, Annex A.

A pWPS shall be used as the basis for the establishment of a welding procedure qualification record (WPQR). The pWPS shall be tested in accordance with one of the methods listed in [Clause 5](#) (welding procedure test) or [Clause 6](#) (pre-production welding test). [Clause 5](#) shall be used when the production part or joint geometry is accurately represented by a standardized test piece or pieces, as shown in [5.2](#). [Clause 6](#) shall be used when the production part or joint geometry is not accurately represented by the standardized test pieces, as shown in [5.2](#). The information required in a pWPS is given in [4.2](#).

For some applications, it can be necessary to supplement or reduce the content of the pWPS given in [4.2](#).

A welding procedure specification (WPS) covers a certain range of parent material thicknesses as well as a range of aluminium alloys.

Ranges and tolerances in accordance with the relevant International Standard (see [Clause 2](#)) and the fabricator's experience shall be specified when appropriate.

An example of a pWPS form for force and position controlled friction stir welding is shown in [Annex A](#).

Alternative process control methods can be used such as temperature control. Essential variables of the alternative process control method need to be documented in the pWPS.

4.2 Technical content of a pWPS

The following information, as a minimum, shall be included in a pWPS:

- a) fabricator information:
 - identification of the fabricator;
 - identification of the pWPS;
- b) parent material type(s), temper(s), and reference standard(s);
- c) parent material dimensions:
 - thickness of the members comprising the welded joint;
 - outside diameter of tube;
- d) equipment identification:
 - model;
 - serial number;
 - equipment fabricator;
- e) tool identification:
 - material;

- drawing or drawing number;
- f) clamping arrangement:
- method and type of jiggling, fixtures, rollers, and backing (dimensions and material);
 - tack welding process and conditions, when required;
 - the pWPS shall indicate any required tack welding or prohibited tack welding;
 - assembly requirements (i.e. welding gap, misalignment);
- g) joint design:
- sketch of the welded joint design and dimensions;
 - joint configuration;
 - weld run sequence and direction;
 - run-on and run-off plates, material type, reference standard, dimensions and method of attachment (if required);
 - placement of exit hole;
- h) joint preparation and cleaning methods;
- i) welding details: iTeh STANDARD PREVIEW
(standards.iteh.ai)
- method (basic, stationary, shoulder, bobbin tool, etc.);
 - tool motion (e.g. rotation in either the clockwise or anticlockwise direction, rotation speed including downward and upward motion);
 - tool position (e.g. heel plunge depth) or axial force, as applicable;
 - tool cooling (internal, external, cooling medium), if applicable;
 - tilt angle;
 - side tilt angle, lateral offset;
 - dwell time at start of weld;
 - dwell time at end of weld;
 - weld overlap area (WOA) for a butt joint or lap joint in tube;
 - lap joint: advancing or retreating side near the upper sheet edge, direction of welding, depth of probe penetration in lower sheet;
- j) welding speed:
- welding speed, including details of any changes during welding;
 - ramp-up/ramp-down or upslope/downslope speeds when applied;
- k) welding position: applicable welding positions;
- l) thermal management:
- details of any pre-weld heat treatment, if applicable;

- details of the preheating temperature, preheat maintenance temperature and/or interpass temperature for the base materials or the friction stir welding tool, if applicable (use of ISO 13916 is recommended);
 - details of any postweld heat treatment (e.g. solution heat treatment, ageing, stress relieving), if applicable;
 - details of any methods for managing the cooling rates (e.g. gas flows, liquid environments) applied prior, during or after welding, if applicable;
- m) postweld (mechanical) processing: methods to correct distortion and straighten parts, removal of toe flash or any other postweld processing of the weldment.

5 Qualification based on a welding procedure test

5.1 General

The preparation, welding and testing of test pieces shall be in accordance with [5.2](#) and [5.3](#).

Fulfilment of the requirements of this document can also serve to qualify the welding operator (see ISO 25239-3).

5.2 Test pieces

5.2.1 Shape and dimensions of test pieces

5.2.1.1 General

The length or number of test pieces shall be sufficient to allow all required tests to be performed.

Test pieces longer than the minimum size may be used to allow for the provision of extra specimens, for re-testing specimens or both (see [5.3.4](#)).

The rolling direction or extrusion direction shall be marked on the test piece.

To produce a butt joint in flat material, the test piece shall be prepared in accordance with [Figure 1](#). The length of the test piece should allow a weld length of at least 500 mm.

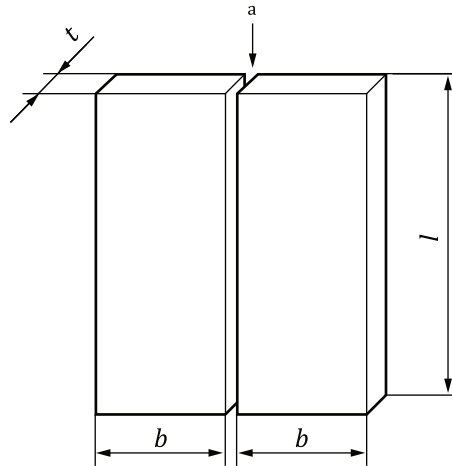
**Key**

- b width of components
- l length of components
- t material thickness
- a Joint preparation and fit-up, as specified in the pWPS.

Figure 1 — Test piece for a butt joint in sheet

iTeh STANDARD PREVIEW

5.2.1.2 Butt joint in tube

(standards.iteh.ai)

The test piece shall be prepared in accordance with [Figure 2](#).

ISO 25239-4:2020

<https://standards.iteh.ai/catalog/standards/sist/cdb07390-f715-408b-b6da-cccc1af2ebef/iso-25239-4-2020>

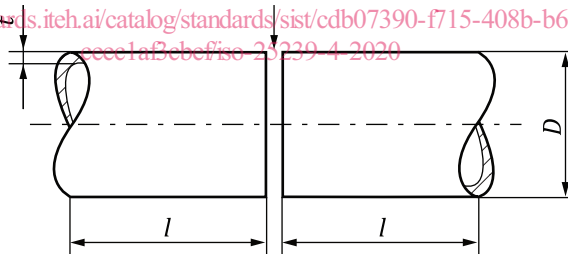
**Key**

- D outside diameter of tube
- l length of components
- t material thickness
- a Joint preparation and fit-up, as specified in the pWPS.

Figure 2 — Test piece for a butt joint in tube**5.2.1.3 Lap joint**

The test piece shall be prepared in accordance with [Figure 3](#).

The weld may be either partial or full penetration through all the sheets.

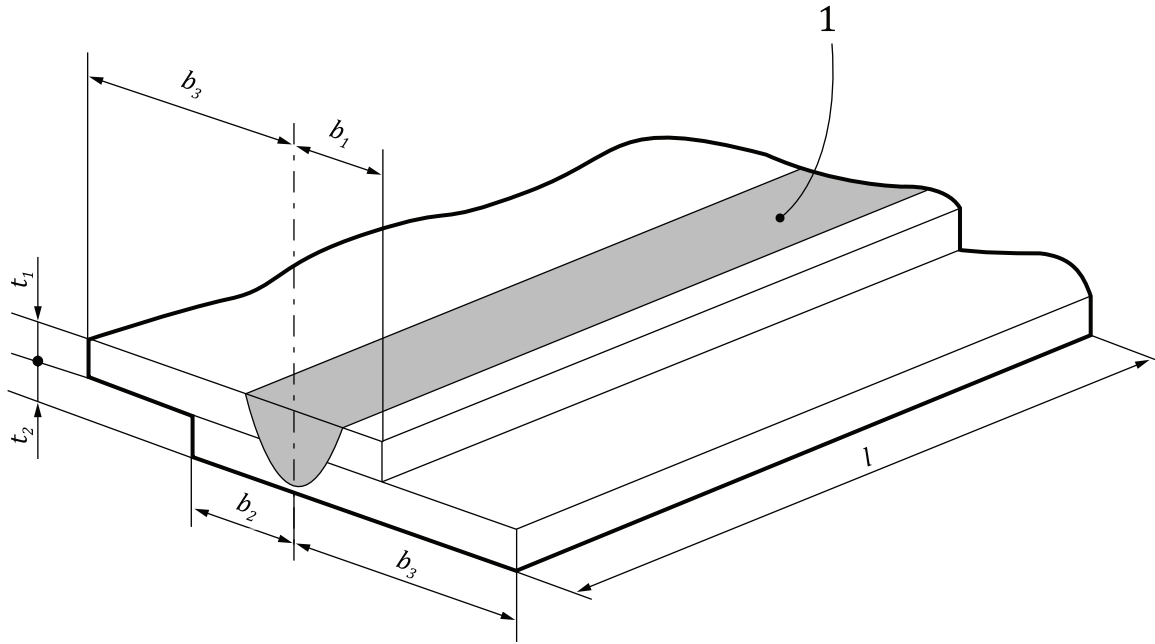

Key

- 1 weld
- b_1 edge to weld centreline distance of upper sheet, as specified in the pWPS
- b_2 edge to weld centreline distance of lower sheet, as specified in the pWPS
- b_3 distance between weld centre and edge of test piece
- l length of components
- t_1 parent material thickness of upper sheet
- t_2 parent material thickness of lower sheet

<https://standards.iteh.ai/catalog/standards/sist/cdb07390-f715-408b-b6da-ceec1af3cbef/iso-25239-4-2020>
 ISO 25239-4:2020
 (standards.iteh.ai)

Figure 3 — Test piece for a lap joint

5.2.2 Welding of test pieces

The test pieces shall be welded in accordance with the pWPS. If tack welds are to be consumed during friction stir welding of the production joint, then they shall be included in the test specimens. The location of tack welds shall be clearly marked on the test piece. Samples should be assessed from both tacked and un-tacked weld areas.

Welding of the test pieces shall be witnessed by an examiner.

5.3 Examination and testing of test pieces

5.3.1 Extent of testing

Testing includes both non-destructive testing (NDT) and destructive testing. Testing shall be performed in accordance with the requirements of [Table 1](#) or [Table 2](#). [Annex B](#) provides additional information on NDT.

Examination of the test results shall be verified by an examiner.