



Designation: ~~D5417-05~~ Designation: D5417 - 11

Standard Practice for Operation of the Vettermann Drum Tester¹

This standard is issued under the fixed designation D5417; the number immediately following the designation indicates the year of original adoption or, in the case of revision, the year of last revision. A number in parentheses indicates the year of last reappraisal. A superscript epsilon (ϵ) indicates an editorial change since the last revision or reappraisal.

1. Scope

1.1 This practice describes the equipment and operation of the Vettermann drum tester for testing pile yarn floor covering to produce changes in appearance and color due to changes in surface structure by mechanical action.

1.2 This practice is only applicable for use in testing unused pile floor covering of all types. It is not applicable for use in testing used pile yarn floor coverings.

~~1.3 The values stated in inch-pound units are to be regarded as the standard for all measurements except mass. The SI (metric) units for all measurements except mass are provided for information only.~~

1.3 The values stated in inch-pound units are to be regarded as standard. The values given in parentheses are mathematical conversions to SI units that are provided for information only and are not considered standard.

1.4 This standard does not purport to address all of the safety concerns, if any, associated with its use. It is the responsibility of the user of this standard to establish appropriate safety and health practices and determine the applicability of regulatory limitations prior to use.

2. Referenced Documents

2.1 *ASTM Standards:*²

D123 [Terminology Relating to Textiles](#)

D1776 [Practice for Conditioning and Testing Textiles](#)

D5684 [Terminology Relating to Pile Floor Coverings](#)

3. Terminology

3.1 For definitions of terms relating to Pile Floor Coverings, D13.21, refer to Terminology D5684.

3.1.1 The following terms are relevant to this standard: carpet, finished, finished pile yarn floor covering, floor covering, lengthwise direction, pile, pile lay, pile yarn floor covering, pitch, practice, primary backing, secondary backing, textile floor covering, texture, tufted fabric.

3.2 For all other terminology related to textiles, refer to Terminology D123.

4. Summary of Practice

4.1 The test specimen is mounted in the rotatable drum with the pile surface towards the center of the drum and the edges under the retaining segments. A steel ball, with 14 rubber studs rolls randomly inside the drum on the pile surface for a specified number of revolutions.

5. Significance and Use

5.1 This equipment may be used to bring about the changes in texture on the surface of pile floor covering caused by mechanical action.

5.2 The acceptance criteria of this practice shall be set by mutual agreement between the purchaser and the supplier.

6. Apparatus and Material

6.1 *Vettermann Drum Tester (See Fig. 1):*

6.1.1 *Drum*, incorporating a revolution counter and four adjustable retaining segments (thickness: ~~15±1 mm (0.6±0.03~~

¹ This practice is under the jurisdiction of ASTM Committee D13 on Textiles and is the direct responsibility of Subcommittee D13.21 on Pile Floor Coverings. Current edition approved March 1, 2005. Published April 2005. Originally approved in 1999. Last previous edition approved in 2003 as D5417-99 (2003). DOI: 10.1520/D5417-05.

Current edition approved Aug. 1, 2011. Published September 2011. Originally approved in 1999. Last previous edition approved in 2005 as D5417-05. DOI: 10.1520/D5417-11.

² For referenced ASTM standards, visit the ASTM website, www.astm.org, or contact ASTM Customer Service at service@astm.org. For *Annual Book of ASTM Standards* volume information, refer to the standard's Document Summary page on the ASTM website.

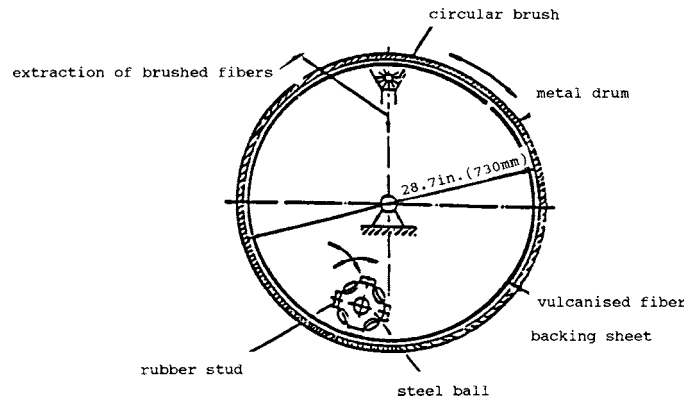

FIG. 1 Vettermann Drum Tester

in.) 0.60 ± 0.03 in. (15 ± 1 mm) on each side wall of the drum. A free-running circular brush mounted in such a way that it lightly contacts the surface of specimens and loose fibers are continuously extracted by a vacuum cleaner. A vulcanized fiber backing sheet 2320×93.3 by 270×10.6 by 1.5 mm (93.30×106 in. (2320 by 106.270 by 0.06 in.) 1.5 mm) is loosely laid inside the drum. This sheet remains permanently in the drum.

6.1.2 The Vettermann drum dimensions are as follows:

Internal diameter	730 ± 10 mm	(28.7 ± 0.39 in.)
Internal diameter	28.70 ± 0.39 in.	(730 ± 10 mm)
Internal depth	270 ± 5 mm	(10.6 ± 0.20 in.)
Internal depth	10.60 ± 0.20 in.	(270 ± 5 mm)
Effective depth	240 ± 7 mm	(9.4 ± 0.28 in.)
Effective depth	9.40 ± 0.28 in.	(240 ± 7 mm)
Thickness of curved surface	8 ± 0.5 mm	(0.31 ± 0.02 in.)
Thickness of curved surface	0.31 ± 0.02 in.	(8 ± 0.5 mm)

6.1.3 *Driving System*, with a speed of 1.65 rad/s (16 ± 1 rpm) and the direction of rotation is reversed every five minutes, stopping between reversals for approximately 1 s time intervals, with approximately one second stationary time.

6.1.4 *Protective Cage*, fits over the drum and must be in place prior to Vettermann drum rotation.

6.1.5 *Round Steel Ball*, fitted with fourteen cylindrical rubber studs located equally spaced on the ball surface. The studs are replaceable and are screwed into flat faces on the surface of the ball. (See Fig. 2.):

Diameter of ball	120 ± 0.2 mm	(4.7 ± 0.01 in.)
Diameter of ball	4.70 ± 0.01 in.	(120.0 ± 0.2 mm)
Distance between diametrically opposed flat stud-mounting faces	118 ± 0.1 mm	(4.6 ± 0.01 in.)
Distance between diametrically opposed flat stud-mounting faces	4.60 ± 0.01 in.	(118.0 ± 0.1 mm)
Mass without studs	6800 ± 100 g	(15.0 ± 0.2 lb)
Mass without studs	15.0 ± 0.2 lb	(6800 ± 100 g)
Mass with studs	7600 ± 100 g	(16.8 ± 0.2 lb)
Mass with studs	16.8 ± 0.2 lb	(7600 ± 100 g)

6.1.6 *Replaceable Rubber Studs*, are a composite rubber disk attached to a steel backing plate with integral mounting screw. The dimensions are:

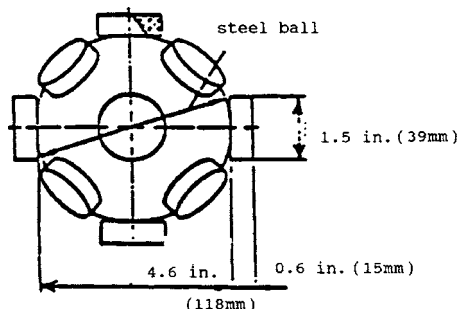

FIG. 2 Round Steel Ball