



SLOVENSKI STANDARD
kSIST-TP FprCEN/TR 1591-6:2024
01-oktober-2024

Prirobnice in prirobnični spoji - Pravila za izračun okroglih prirobnic s tesnili - 6.
del: Temeljne informacije

Flanges and their joints - Design rules for gasketed circular flange connections - Part 6:
Background information

Flansche und ihre Verbindungen - Regeln für die Auslegung von Flanschverbindungen
mit runden Flanschen und Dichtung - Teil 6: Hintergrund-Informationen

Brides et leurs assemblages - Règles de calcul des assemblages à brides circulaires
avec joint - Partie 6: Document de référence

Ta slovenski standard je istoveten z: FprCEN/TR 1591-6

[kSIST-TP FprCEN/TR 1591-6:2024](http://standards.sist.si/standards/kSIST-TP-FprCEN-TR-1591-6-2024)

ICS:

23.040.60	Prirobnice, oglavki in spojni elementi	Flanges, couplings and joints
23.040.80	Tesnila za cevne zveze	Seals for pipe and hose assemblies

kSIST-TP FprCEN/TR 1591-6:2024 **en**

TECHNICAL REPORT
RAPPORT TECHNIQUE
TECHNISCHER REPORT

FINAL DRAFT
FprCEN/TR 1591-6

August 2024

ICS 23.040.60

Will supersede CR 13642:1999

English Version

Flanges and their joints - Design rules for gasketed circular flange connections - Part 6: Background information

Brides et leurs assemblages - Règles de calcul des assemblages à brides circulaires avec joint - Partie 6: Document de référence

Flansche und ihre Verbindungen - Regeln für die Auslegung von Flanschverbindungen mit runden Flanschen und Dichtung - Teil 6: Hintergrund-Informationen

This draft Technical Report is submitted to CEN members for Vote. It has been drawn up by the Technical Committee CEN/TC 74.

CEN members are the national standards bodies of Austria, Belgium, Bulgaria, Croatia, Cyprus, Czech Republic, Denmark, Estonia, Finland, France, Germany, Greece, Hungary, Iceland, Ireland, Italy, Latvia, Lithuania, Luxembourg, Malta, Netherlands, Norway, Poland, Portugal, Republic of North Macedonia, Romania, Serbia, Slovakia, Slovenia, Spain, Sweden, Switzerland, Türkiye and United Kingdom.

Recipients of this draft are invited to submit, with their comments, notification of any relevant patent rights of which they are aware and to provide supporting documentation.

Warning : This document is not a Technical Report. It is distributed for review and comments. It is subject to change without notice and shall not be referred to as a Technical Report.

[ksist-tp FprCEN/TR 1591-6:2024](https://standards.iteh.ai/catalog/standards/sist/c91c571d-1a1c-42aa-b41a-670874fa3451/ksist-tp-fprcen-tr-1591-6-2024)

<https://standards.iteh.ai/catalog/standards/sist/c91c571d-1a1c-42aa-b41a-670874fa3451/ksist-tp-fprcen-tr-1591-6-2024>



EUROPEAN COMMITTEE FOR STANDARDIZATION
COMITÉ EUROPÉEN DE NORMALISATION
EUROPÄISCHES KOMITEE FÜR NORMUNG

CEN-CENELEC Management Centre: Rue de la Science 23, B-1040 Brussels

Contents

	Page
European foreword	4
1 Scope	5
2 Normative references.....	5
3 Terms and definitions.....	5
4 Introduction.....	5
5 Forces in gasketed joints.....	6
5.1 Definition of active and passive forces	6
5.2 Coupling of internal forces	6
5.3 Assembly conditions	7
6 Gasket characteristics.....	8
6.1 Mechanical behavior	8
6.1.1 General	8
6.1.2 Unloading modulus (E_G)	8
6.1.3 Creep/relaxation	8
6.1.4 Maximum compressive stress	9
6.2 Sealing criteria	9
6.3 Effective width	10
7 Calculations for gaskets.....	11
7.1 Effective width of gaskets.....	11
7.1.1 Flat gaskets	11
7.1.2 Effective width of gaskets with curved surfaces.....	13
7.2 Elastic stiffness of gaskets.....	14
7.3 Load carrying capability of gaskets.....	15
8 Calculations for bolts.....	17
8.1 Elastic stiffness of bolts.....	17
8.2 Load carrying capacity of bolts.....	17
8.3 Bolt tightening by torque-wrench.....	17
9 Elasticity of shells	18
9.1 Conical and spherical shells with uniform wall-thickness	18
9.2 Conical hub with cylindrical shell.....	22
10 Elasticity of complete flange.....	25
10.1 Flange ring without shell.....	25
10.2 Flange ring connected to shell.....	28
11 Limit loads of shells	30
11.1 Conical and spherical shells with constant wall thickness.....	30
11.2 Conical hub with cylindrical shell.....	35
12 Limit loads for complete flange	40
12.1 Flange ring without shell.....	40
12.2 Flange ring connected to shell.....	41
13 Validity limits.....	42
13.1 Diameter relations	42
13.2 Thickness relations.....	43

13.3	Angle of connected shell	44
13.4	Bolt spacing	44
Annex A (informative) Conical and spherical shells (uniform wall thickness) — Verification of Formulae (9.33) to (9.35)		
		47
Annex B (informative) Experimental verification		
		52
B.1	General	52
B.2	Test information	54
Annex C (informative) Limit load formulae		
		77
C.1	Limit load formulae for any shell	77
C.2	Limit load formulae for axisymmetric shell	78
Bibliography		
		81

iTeh Standards
(<https://standards.iteh.ai>)
Document Preview

[kSIST-TP FprCEN/TR 1591-6:2024](https://standards.iteh.ai/catalog/standards/sist/c91c571d-1a1c-42aa-b41a-670874fa3451/ksist-tp-fprcen-tr-1591-6-2024)

<https://standards.iteh.ai/catalog/standards/sist/c91c571d-1a1c-42aa-b41a-670874fa3451/ksist-tp-fprcen-tr-1591-6-2024>

FprCEN/TR 1591-6:2024 (E)

European foreword

This document (FprCEN/TR 1591-6:2024) has been prepared by Technical Committee CEN/TC 74 “Flanges and their joints”, the secretariat of which is held by DIN.

This document is currently submitted to the Vote on TR.

This document will supersede CR 13642:1999.

FprCEN/TR 1591-6:2024 includes the following significant technical changes with respect to CR 13642:1999:

- Update of 6.1.2, 6.1.3, 6.1.4 and 6.2 regarding evolution within FprEN 1591-1:2024 related to gasket parameters.

NOTE This is not an exhaustive list of all modifications.

This document is part of a series that consists of the following parts:

- EN 1591-1, *Flanges and their joints — Design rules for gasketed circular flange connections — Part 1: Calculation*
- CEN/TR 1591-2, *Flanges and their joints — Design rules for gasketed circular flange connections — Part 2: Gasket parameters*
- CEN/TS 1591-3, *Flanges and their joints — Design rules for gasketed circular flange connections — Part 3: Calculation method for metal-to-metal contact type flanged joint*
- EN 1591-4, *Flanges and their joints — Part 4: Qualification of personnel competency in the assembly of the bolted connections of critical service pressurized systems*
- CEN/TR 1591-5, *Flanges and their joints — Design rules for gasketed circular flange connections — Part 5: Calculation method for full face gasketed joints*
- CEN/TR 1591-6, *Flanges and their joints — Design rules for gasketed circular flange connections — Background information*

1 Scope

This document gives background information for guidance to be used in conjunction with the calculation method for design rules for gasketed circular flange connections as specified in FprEN 1591-1:2024.

NOTE References to formulae numbered in this document have a decimal format whilst those in FprEN 1591-1:2024 are indicated by whole numbers.

2 Normative references

There are no normative references in this document.

3 Terms and definitions

No terms and definitions are listed in this document.

ISO and IEC maintain terminology databases for use in standardization at the following addresses:

- ISO Online browsing platform: available at <https://www.iso.org/obp/>
- IEC Electropedia: available at <https://www.electropedia.org/>

4 Introduction

Strength assessments in design calculations generally involve a 'proof of load' in the form:

$$\text{actual loads} \leq \text{allowable loads} \quad (4.1)$$

and similarly, when determining wall thicknesses, etc. The classical basis is linear elasticity theory, for which proofs are often written:

$$\text{actual stresses} \leq \text{allowable stresses} \quad (4.2)$$

However, elasticity theory can lead to illogical results such as stress increasing (strength decreasing) with increasing wall thickness. On the other hand, plasticity theory avoids such inconsistencies and Limit Load Analysis gives reliable results. Therefore, in FprEN 1591-1:2024 Limit Load Analysis is used as the basis for proof of load.

To ensure adequate leak-tightness, it is important that gasket compressive stress Q does not fall below a certain value. For example, in the ASME Boiler and Pressure Vessel Code, Section VIII ('ASME' hereafter) the proof for leak-tightness is:

$$Q \geq m \cdot |P| \quad (4.3)$$

where m is a 'gasket factor' and P is fluid pressure.

NOTE The general form of a leak-tightness proof is equivalent to a load proof of the form:

$$\text{actual load} \geq \text{required load} \quad (4.4)$$

It follows that both upper and lower limits are imposed on gasket and bolt loads, as in:

$$\text{required load} \leq \text{actual load} \leq \text{allowable load} \quad (4.5)$$

FprCEN/TR 1591-6:2024 (E)

Various commonly used design codes (e.g. ASME and related codes) for gasketed joints do not apply this condition but assume:

$$\text{required load} = \text{actual load} \quad (4.6)$$

and neglect interactions between assembly and subsequent test or service conditions, or additional assumptions are introduced (e.g. 'gasket force is constant'). This is a poor model of real joints and leakage problems result.

A code which properly treats all load conditions (assembly, test, and all service conditions) is TGL 32903/13 (1983), a National Standard of the former German Democratic Republic. Variants of this have been in use since 1973 and it has been applied to the design of thousands of gasketed joints without leakage problems. Therefore, when CEN/TC/74/WG 10 "Flanges and their joints - Calculation methods" was requested to produce a design procedure for gasketed joints, the TGL method was chosen as the basis. At the request of CEN/TC 54/WG 53 "Unfired pressure vessels – Design methods" the scope of the TGL version was extended, with basic principles unchanged. The established validity was unaffected by this extension but behaviour in the new domain has yet to be verified. Examples of validation tests for the original domain are given in Annex B.

5 Forces in gasketed joints

5.1 Definition of active and passive forces

Active forces (and moments) are those which can, in principle, cause unlimited deformation. Examples in joints are the axial fluid-pressure force F_Q and an external dead-weight force F_A . If limited plastic deformation is possible without loss of function (as in dished heads) only active forces are required in the proof of load.

Passive forces (and moments) are due to limited elastic deformation and can only cause limited deformation (they do affect fatigue). An example is a force due to differential thermal expansion. If limited plastic deformations can cause loss of function, passive forces are also included in the proof of load.

NOTE This is partially true in the case of leak-tightness. Differential thermal expansion ΔU_I can cause plastic deformation, with loss of bolt and gasket force, and hence of leak-tightness. Therefore ΔU_I is included in the calculation of F_{GI} , F_{BI} and in the proof of load. On the other hand, scatter of assembly bolt-load is not considered in Formula (118). This is because if assembly bolt-load exceeds the minimum (to ensure subsequent leak-tightness) and limited plastic deformation occurs in a subsequent condition, the forces can fall to the minimum required without loss of leak-tightness.

5.2 Coupling of internal forces

Under both assembly conditions and subsequent load conditions the component parts of a gasketed joint are coupled by internal forces. Therefore, the following geometric relation exists between displacements of parts:

$$\begin{aligned} (\theta_F \cdot h_G + \tilde{\theta}_F \cdot \tilde{h}_G + \theta_L \cdot h_L + \tilde{\theta}_L \cdot \tilde{h}_L + U_B + U_G)_{(I=0)} = \\ (\theta_F \cdot h_G + \tilde{\theta}_F \cdot \tilde{h}_G + \theta_L \cdot h_L + \tilde{\theta}_L \cdot \tilde{h}_L + U_B + U_G + \Delta U_I)_{(I \geq 1)} \end{aligned} \quad (5.1)$$

Substituting θ_F , θ_L (see Formulae (C.1), (C.2)) and U_B , U_G (Formulae (8.1, 7.27, 7.29)) and the equilibrium condition.

$$F_B = F_G + F_Q + F_R, \text{ for all } I \quad (5.2)$$

gives:

$$F_{G0} \cdot Y_{G0} + F_{Q0} \cdot Y_{Q0} + F_{R0} \cdot Y_{R0} = F_{GI} \cdot Y_{GI} + F_{QI} \cdot Y_{QI} + F_{RI} \cdot Y_{RI} + \Delta U_I \quad (5.3)$$

This is the fundamental formula relating force changes in a joint, subject to $F_{Q0} = 0$ ($P_{I=0} = 0$). The flexibility parameters Y_B, Y_G, Y_Q, Y_R are given in Formulae (97) to (100).

If the required gasket force (Formula 102) is known for subsequent conditions (e.g. from pressure P_I and gasket factor m_I), then from Formula (8.3) the assembly force to ensure leak-tightness is:

$$F_{G0} \geq (F_{GI} \cdot Y_{GI} + F_{QI} \cdot Y_{QI} + F_{RI} \cdot Y_{RI} - F_{R0} \cdot Y_{R0} + \Delta U_I) / Y_{G0} \quad (5.4)$$

which is the basis of Formula (103).

NOTE In Formula (103) of actual FprEN 1591-1:2024, an additional term (P_{QR}) is introduced to take the gasket creep phenomena into account (see 6.1.3).

If there is more than one subsequent condition, the largest assembly force is selected in order to be sufficient for all of them (Formula (105)). In the other subsequent conditions (not associated to the largest assembly bolt force) the gasket force is greater than required. Gaskets, flanges and bolts ability to withstand this additional force are checked (Formula (120)).

5.3 Assembly conditions

The bolt-tightening method is selected to produce a bolt load not less than the required minimum; thus, due to scatter, the target bolt load is greater than this minimum. These effects are considered in FprEN 1591-1:2024, subclause 4.4.2. The scatter parameter can be defined in various ways. In FprEN 1591-1:2024 the following 'linear definition' is used (as in VDI 2230):

$$\check{F}_{B0} = \bar{F}_{B0} \cdot (1 - \varepsilon); \quad \hat{F}_{B0} = \bar{F}_{B0} \cdot (1 + \varepsilon) \quad (5.5)$$

$$\bar{F}_{B0} = \frac{(\check{F}_{B0} + \hat{F}_{B0})}{2}; \quad 0 < \varepsilon < 1 \quad (5.6)$$

An alternative possibility is the "geometric definition":

$$\check{F}_{B0} = \bar{F}_{B0} / (1 + \varepsilon); \quad \hat{F}_{B0} = \bar{F}_{B0} \cdot (1 + \varepsilon) \quad (5.7)$$

$$\bar{F}_{B0} = \sqrt{\check{F}_{B0} \cdot \hat{F}_{B0}}; \quad 0 < \varepsilon < \infty \quad (5.8)$$

These definitions are nearly the same for $0 < \varepsilon < 0,1 \dots 0,2$, but the alternative definitions account for disagreements between published data. In FprEN 1591-1:2024, examples of ε are given based on the linear definition.

6 Gasket characteristics

6.1 Mechanical behavior

6.1.1 General

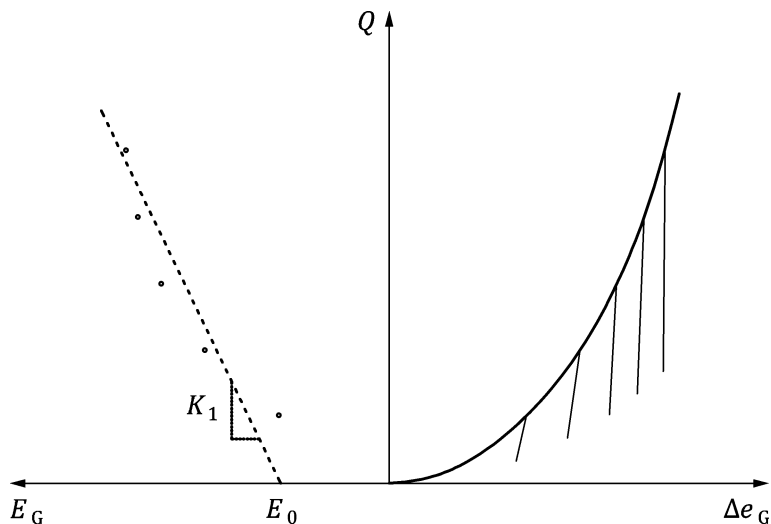

Figure 1 — Gasket mechanical behaviour

When structural deformation was not considered, the details of gasket behaviour were of less concern, but with the present more comprehensive approach they need further consideration. As indicated schematically in Figure 1, the relationship between the load (Q) and the gasket deflection in compression (Δe_G) is very non-linear for most gasket types.

6.1.2 Unloading modulus (E_G)

The initial-loading line (see right side of Figure 1) is strongly non-linear. The unloading-lines (see left side of Figure 1) were initially considered approximately linear with slope increasing with assembly stress. In reality, the unloading line is not strictly linear. Its slope reduces at lower stresses. Therefore, to measure E_G , a detailed definition is given in EN 13555:2021. The corresponding values of unloading modulus E_G , are plotted on the left side of the diagram.

In FprEN 1591-1:2024, these values were considered varying almost linearly with assembly stress:

$$E_G \approx E_0 + K_1 \cdot Q_0 \quad (6.1)$$

In the following revisions of FprEN 1591-1:2024, based on EN 13555:2021 test results, it has been decided to use directly tabulated values of $E_G(Q_0)$ without using the linear model given in (6.1).

6.1.3 Creep/relaxation

When a gasket is subjected to compressive stress an immediate elastic (or elastic-plastic) deformation U_G occurs followed by creep, increasing deformation with time at constant load. The Figure 2 shows this diagrammatically.

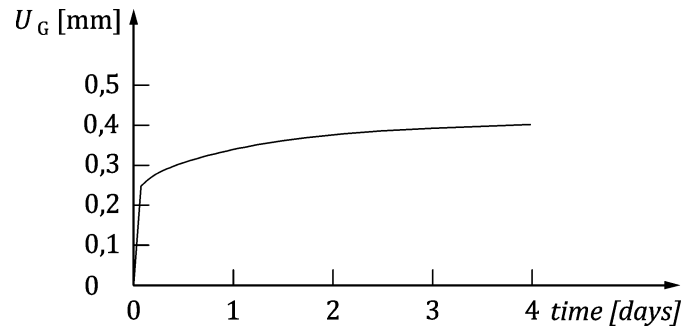

Figure 2 — Creep/relaxation

In the case of a bolted connection, the load applied on the gasket will not be held constant. The gasket deflection due to creep will lead to the reduction of the internal forces in the assembly. The amount of force reduction on the gasket will depend on the compliance of the bolted connection components. Therefore, the gasket creep/relaxation behaviour is handled through a creep/relaxation factor called P_{QR} defined as the ratio of the residual and initial surface pressures. EN 13555:2021 details the test procedure enabling to measure this parameter.

6.1.4 Maximum compressive stress

The maximum surface pressure (Q_{smax}) that can be safely imposed upon the gasket at the service temperature without damage is determined through EN 13555:2021 tests. In FprEN 1591-1:2024, the measured value of Q_{smax} was modified by a factor c_G , (Formula (7.43) and Formula (13.24)) that makes allowance for the gasket width in relation to thickness. For recording purposes, the explanation for this correction is maintained in this document even if it is no longer used in the actual version of FprEN 1591-1:2024.

6.2 Sealing criteria

$Q_{min(L)}$ is the minimum level of gasket surface pressure required for tightness class L at assembly (on the effective gasket area). $Q_{smin(L)}$ is the minimum level of surface pressure required for leakage rate class L after off-loading. Q_A is the associated required gasket surface pressure at assembly prior to unloading. $Q_{min(L)}$, Q_A and $Q_{smin(L)}$ are variables which are determined in a leakage test according to EN 13555:2021 and which are linked to each other. The lowest acceptable value of Q_A is equal to $Q_{min(L),I}$, in this case $Q_A = Q_{min(L),I} = Q_{smin(L),I}$. The higher Q_A can be chosen, the lower $Q_{smin(L),I}$ can get.

FprCEN/TR 1591-6:2024 (E)

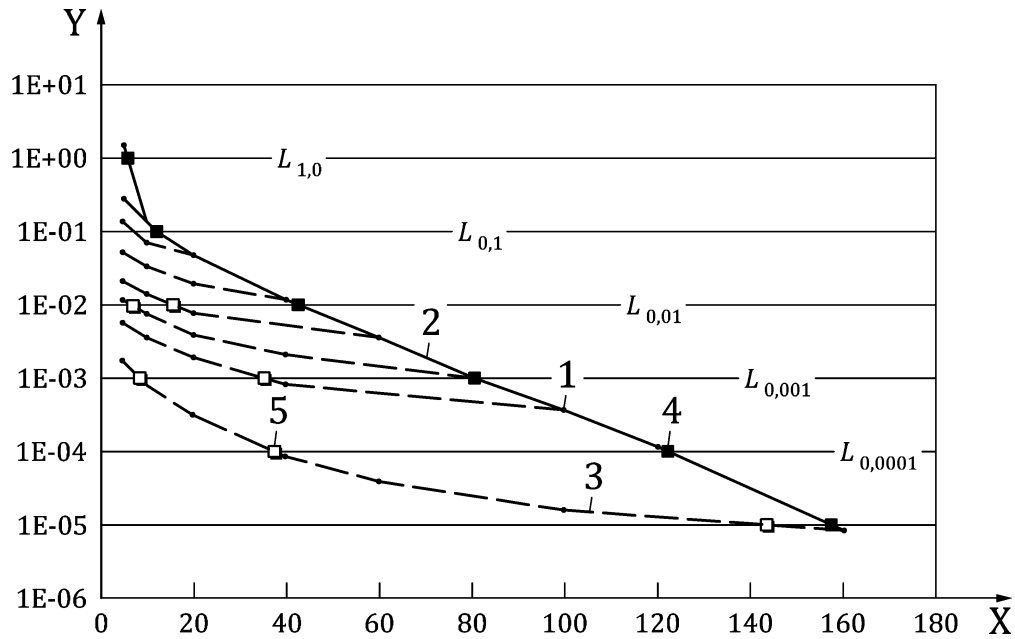

Key

- 1 measurement point
- 2 loading
- 3 unloading
- 4 Q_{min}(L)
- 5 Q_{smin}(L)
- X effective gasket surface pressure [in MPa]
- Y leakage rate [in mg/(m s)]

Figure 3 — Leakage rate as a function of gasket surface pressure (for one specific internal pressure level of the fluid)

6.3 Effective width

The effective width of a gasket varies with flange rotation, which also causes a radial variation of compressive stress. Strictly, an iterative calculation is needed to reconcile the changing width, gasket stresses and bolt load. However, the approach adopted in FprEN 1591-1:2024 is to calculate gasket-width for the assembly condition and then assumed this to be unchanged for subsequent conditions. This simplifying assumption is strictly correct only if gasket-force F_G and flange rotations do not change. However, the assumption is conservative if the effective width for subsequent conditions is actually smaller than in the assembly condition, which is often the case.

7 Calculations for gaskets

7.1 Effective width of gaskets

7.1.1 Flat gaskets

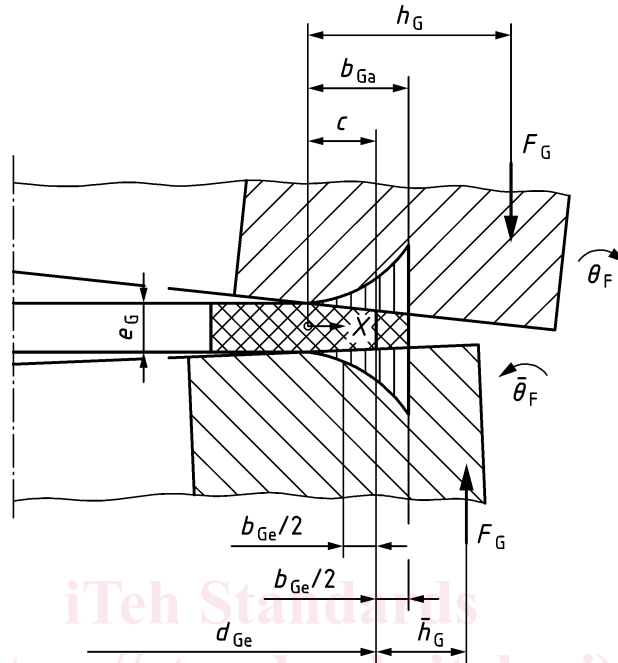

Key

b_{Ga} = contact width

b_{Ge} = effective width

b_{Gc} = calculated width

$Q(x)$ = compressive stress

KSIST-TP FprCEN/TR 1591-6:2024

<https://standards.iteh.ai/catalog/standards/sist/c91c571d-1a1c-42aa-b41a-670874fa3451/ksist-tp-fprcen-tr-1591-6-2024>

Figure 4 — Flat gaskets

Elastic rotation of flanges (see Formula (10.36)):

$$\Theta_F + \tilde{\Theta}_F = F_G \cdot (Z_F \cdot h_G / E_F + \tilde{Z}_F \cdot \tilde{h}_G / \tilde{E}_F) \quad (7.1)$$

Elastic deformation of gasket (for $0 \leq x \leq b_{Ga}$):

$$\varepsilon = (\Theta_F + \tilde{\Theta}_F) \cdot x / e_G = k \cdot x \quad (7.2)$$

$$E_G = E_0 + K_1 \cdot Q = \frac{dQ}{d\varepsilon} \quad (7.3)$$

$$Q = \frac{E_0}{K_1} \cdot (\exp(K_1 \cdot \varepsilon) - 1) \approx E_0 \cdot \varepsilon \cdot \left(1 + \frac{1}{2} \cdot K_1 \cdot \varepsilon\right) \quad (7.4)$$

The resultant gasket force F_G is:

$$F_G = \pi \cdot d_{Ge} \cdot \int_0^{b_{Ga}} Q(x) \cdot dx \quad (7.5)$$

acting at $x = c$, given by:

FprCEN/TR 1591-6:2024 (E)

$$c \cdot \int_0^{b_{Ga}} Q(x) \cdot dx = \int_0^{b_{Ga}} Q(x) \cdot x \cdot dx \quad (7.6)$$

From this follow, step by step:

$$F_G = \pi \cdot d_{Ge} \cdot E_0 \cdot k \cdot \frac{1}{2} \cdot b_{Ga}^2 \cdot \left(1 + \frac{1}{3} \cdot K_1 \cdot k \cdot b_{Ga}\right) \quad (7.7)$$

$$b_{Ga} = \sqrt{\frac{F_G \cdot e_G \cdot 2}{\pi \cdot d_{Ge} \cdot E_0 \cdot (\Theta_F + \tilde{\Theta}_F) \cdot \left(1 + \frac{1}{3} \cdot K_1 \cdot k \cdot b_{Ga}\right)}} \quad (7.8)$$

$$c = \frac{2}{3} \cdot b_{Ga} \cdot \frac{1 + \frac{3}{8} \cdot K_1 \cdot k \cdot b_{Ga}}{1 + \frac{1}{3} \cdot K_1 \cdot k \cdot b_{Ga}} \quad (7.9)$$

$$b_{Gc} = 2 \cdot (b_{Ga} - c) = \frac{2}{3} \cdot b_{Ga} \cdot \frac{1 + \frac{1}{4} \cdot K_1 \cdot k \cdot b_{Ga}}{1 + \frac{1}{3} \cdot K_1 \cdot k \cdot b_{Ga}} \quad (7.10)$$

$$b_{Gc} = \sqrt{\frac{F_G \cdot e_G \cdot \frac{8}{9}}{\pi \cdot d_{Ge} \cdot (\Theta_F + \tilde{\Theta}_F) \cdot E_0}} \cdot \frac{\left(1 + \frac{1}{4} \cdot K_1 \cdot k \cdot b_{Ga}\right)^2}{\left(1 + \frac{1}{3} \cdot K_1 \cdot k \cdot b_{Ga}\right)^3} \quad (7.11)$$

The remaining elimination of $k \cdot b_{Ga}$ is simplified by assuming $K_1 \cdot k \cdot b_{Ga} \cdot \frac{1}{3} \ll 1$, then Formula (7.11) becomes:

$$b_{Gc} = \sqrt{\frac{F_G \cdot e_G \cdot \frac{8}{9}}{\pi \cdot d_{Ge} \cdot (\Theta_F + \tilde{\Theta}_F) \cdot E_0 \cdot \left(1 + \frac{1}{2} \cdot K_1 \cdot k \cdot b_{Ga}\right)}} \quad (7.12)$$

[This approximation gives an error on $b_{Gc} \leq 5\%$ for $K_1 \cdot k \cdot b_{Ga} \leq 10$, almost always true!]

F_Q will be at least:

$$F_Q = \pi \cdot d_{Ge} \cdot b_{Ge} \cdot \bar{Q} \quad \text{where } \bar{Q} \text{ is an average value,} \quad (7.13)$$

and with Formulae (7.7) and (7.10) this gives:

$$E_0 \cdot k \cdot b_{Ga} = Q \cdot \frac{2 \cdot b_{Ge}}{b_{Ga} \cdot \left(1 + \frac{1}{3} \cdot K_1 \cdot k \cdot b_{Ga}\right)} = Q \cdot \frac{4 \cdot b_{Ge}}{3 \cdot b_{Gc}} \cdot \frac{1 + \frac{1}{4} \cdot K_1 \cdot k \cdot b_{Ga}}{\left(1 + \frac{1}{3} \cdot K_1 \cdot k \cdot b_{Ga}\right)^2} \quad (7.14)$$

$$\text{With the approximation: } E_0 \cdot k \cdot b_{Ga} \approx Q \quad (7.15)$$

and omitting the factor 8/9, Formula (7.12) becomes:

$$b_{Gc} = \sqrt{\frac{F_G \cdot e_G}{\pi \cdot d_{Ge} \cdot (\Theta_F + \tilde{\Theta}_F) \cdot \left(E_0 + K_1 \cdot \frac{Q}{2}\right)}} = b_{Gc(el)} \quad (7.16)$$

for elastic behaviour of a gasket

For plastic behaviour:

$$b_{Gc(pl)} = \frac{F_G}{\pi \cdot d_{Ge} \cdot Q_{smax}} \quad (7.17)$$

True elasto-plastic deformation gives an effective-width greater than for pure-elastic and pure-plastic deformation, approximately: