

DRAFT INTERNATIONAL STANDARD

ISO/DIS 15027-3

ISO/TC 188/SC 1

Secretariat: **AFNOR**

Voting begins on:
2023-05-03

Voting terminates on:
2023-07-26

Immersion suits —

Part 3: Test methods

Combinaisons de protection thermique en cas d'immersion —

Partie 3: Méthodes d'essai

ICS: 13.340.10

iTeh Standards
(<https://standards.iteh.ai>)
Document Preview

[ISO/FDIS 15027-3](#)

<https://standards.iteh.ai/catalog/standards/iso/9e85b8ea-ab7b-4519-96a4-57b3753b50a6/iso-fdis-15027-3>

This document is circulated as received from the committee secretariat.

THIS DOCUMENT IS A DRAFT CIRCULATED FOR COMMENT AND APPROVAL. IT IS THEREFORE SUBJECT TO CHANGE AND MAY NOT BE REFERRED TO AS AN INTERNATIONAL STANDARD UNTIL PUBLISHED AS SUCH.

IN ADDITION TO THEIR EVALUATION AS BEING ACCEPTABLE FOR INDUSTRIAL, TECHNOLOGICAL, COMMERCIAL AND USER PURPOSES, DRAFT INTERNATIONAL STANDARDS MAY ON OCCASION HAVE TO BE CONSIDERED IN THE LIGHT OF THEIR POTENTIAL TO BECOME STANDARDS TO WHICH REFERENCE MAY BE MADE IN NATIONAL REGULATIONS.

RECIPIENTS OF THIS DRAFT ARE INVITED TO SUBMIT, WITH THEIR COMMENTS, NOTIFICATION OF ANY RELEVANT PATENT RIGHTS OF WHICH THEY ARE AWARE AND TO PROVIDE SUPPORTING DOCUMENTATION.

ISO/CEN PARALLEL PROCESSING



Reference number
ISO/DIS 15027-3:2023(E)

© ISO 2023

iTeh Standards
(<https://standards.iteh.ai>)
Document Preview

[ISO/FDIS 15027-3](#)

<https://standards.iteh.ai/catalog/standards/iso/9e85b8ea-ab7b-4519-96a4-57b3753b50a6/iso-fdis-15027-3>



COPYRIGHT PROTECTED DOCUMENT

© ISO 2023

All rights reserved. Unless otherwise specified, or required in the context of its implementation, no part of this publication may be reproduced or utilized otherwise in any form or by any means, electronic or mechanical, including photocopying, or posting on the internet or an intranet, without prior written permission. Permission can be requested from either ISO at the address below or ISO's member body in the country of the requester.

ISO copyright office
CP 401 • Ch. de Blandonnet 8
CH-1214 Vernier, Geneva
Phone: +41 22 749 01 11
Email: copyright@iso.org
Website: www.iso.org

Published in Switzerland

Contents

| | Page |
|---|----------|
| Foreword..... | v |
| 1 Scope..... | 1 |
| 2 Normative references..... | 1 |
| 3 Terms and definitions..... | 1 |
| 4 Testing of the device..... | 3 |
| 4.1 General..... | 3 |
| 4.2 Sampling..... | 3 |
| 4.3 Temperature cycling test..... | 3 |
| 4.3.1 General..... | 3 |
| 4.3.2 Procedure..... | 4 |
| 4.4 Rotating shock bin test..... | 4 |
| 4.4.1 General..... | 4 |
| 4.4.2 Apparatus..... | 4 |
| 4.4.3 Procedure..... | 4 |
| 4.4.4 Evaluation..... | 4 |
| 4.5 Tensile strength of seams..... | 5 |
| 4.6 Fuel resistance test..... | 5 |
| 4.7 Buoyancy test..... | 5 |
| 4.7.1 Principle..... | 5 |
| 4.7.2 Apparatus..... | 6 |
| 4.7.3 Procedure..... | 6 |
| 4.7.4 Results..... | 6 |
| 4.8 Suit strength test..... | 6 |
| 4.8.1 Principle..... | 6 |
| 4.8.2 Apparatus..... | 6 |
| 4.8.3 Procedure..... | 6 |
| 4.8.4 Results..... | 7 |
| 4.9 Lifting loop test..... | 7 |
| 4.9.1 Procedure..... | 7 |
| 4.9.2 Results..... | 8 |
| 4.10 Flammability test..... | 8 |
| 4.10.1 Principle..... | 8 |
| 4.10.2 Apparatus..... | 8 |
| 4.10.3 Sampling..... | 8 |
| 4.10.4 Procedure..... | 9 |
| 4.10.5 Evaluation..... | 9 |
| 4.11 Cleaning..... | 10 |
| 4.12 Human test subjects..... | 10 |
| 4.12.1 Instruction and selection..... | 10 |
| 4.12.2 Number and sizes of human test subjects..... | 10 |
| 4.12.3 Gender of human test subjects..... | 10 |
| 4.12.4 Fitness of human test subjects..... | 10 |
| 4.12.5 Dress of human test subjects..... | 11 |
| 4.12.6 Pass/fail criteria..... | 11 |
| 4.13 Leakage measurement..... | 11 |
| 4.13.1 Leakage measurement for jumping..... | 11 |
| 4.13.2 Water ingress measurement for swimming..... | 12 |
| 4.14 Thermal test..... | 12 |
| 4.14.1 Using a thermal manikin..... | 12 |
| 4.14.2 Using human test subjects..... | 15 |
| 4.15 Ergonomic performance testing..... | 18 |
| 4.15.1 General..... | 18 |
| 4.15.2 Donning..... | 18 |

| | | |
|--|--|-----------|
| 4.15.3 | Walking..... | 19 |
| 4.15.4 | Climbing..... | 19 |
| 4.15.5 | Dexterity and mobility..... | 20 |
| 4.16 | In-water performance and field of vision tests..... | 21 |
| 4.16.1 | Jump test..... | 21 |
| 4.16.2 | Secondary donning..... | 21 |
| 4.16.3 | Turning test..... | 21 |
| 4.16.4 | Conspicuity..... | 21 |
| 4.16.5 | Field of vision..... | 22 |
| 4.16.6 | Swim and boarding test..... | 22 |
| 4.17 | Helicopter transit suits..... | 23 |
| 4.17.1 | Helicopter escape (for helicopter transit suits as specified by ISO 15027-1 only)..... | 23 |
| 4.17.2 | Buoyancy measurement (for helicopter transit suits only)..... | 23 |
| Annex A (normative) Test results — Uncertainty of measurement..... | | 24 |
| Annex B (normative) Test protocol and checklist for manikin testing..... | | 25 |
| Annex C (normative) Thermal manikin – Means of circulated water..... | | 32 |
| Annex D (normative) Correlation of thermal manikin systems..... | | 33 |
| Annex E (normative) Thermal insulation identification for suit material — Test methods..... | | 35 |
| Annex F (informative) Medical fitness assessment for human thermal testing in cold water..... | | 42 |
| Annex ZA (informative) Relationship between this European Standard and the essential requirements of Regulation 2016/425 aimed to be covered..... | | 43 |
| Bibliography..... | | 47 |

(https://standards.iteh.ai)
Document Preview

[ISO/FDIS 15027-3](https://standards.iteh.ai/catalog/standards/iso/9e85b8ea-ab7b-4519-96a4-57b3753b50a6/iso-fdis-15027-3)

<https://standards.iteh.ai/catalog/standards/iso/9e85b8ea-ab7b-4519-96a4-57b3753b50a6/iso-fdis-15027-3>

Foreword

ISO (the International Organization for Standardization) is a worldwide federation of national standards bodies (ISO member bodies). The work of preparing International Standards is normally carried out through ISO technical committees. Each member body interested in a subject for which a technical committee has been established has the right to be represented on that committee. International organizations, governmental and non-governmental, in liaison with ISO, also take part in the work. ISO collaborates closely with the International Electrotechnical Commission (IEC) on all matters of electrotechnical standardization.

The procedures used to develop this document and those intended for its further maintenance are described in the ISO/IEC Directives, Part 1. In particular, the different approval criteria needed for the different types of ISO documents should be noted. This document was drafted in accordance with the editorial rules of the ISO/IEC Directives, Part 2 (see www.iso.org/directives).

Attention is drawn to the possibility that some of the elements of this document may be the subject of patent rights. ISO shall not be held responsible for identifying any or all such patent rights. Details of any patent rights identified during the development of the document will be in the Introduction and/or on the ISO list of patent declarations received (see www.iso.org/patents).

Any trade name used in this document is information given for the convenience of users and does not constitute an endorsement.

For an explanation of the voluntary nature of standards, the meaning of ISO specific terms and expressions related to conformity assessment, as well as information about ISO's adherence to the World Trade Organization (WTO) principles in the Technical Barriers to Trade (TBT), see www.iso.org/iso/foreword.html.

This document was prepared by Technical Committee ISO/TC 188, *Small craft*, Subcommittee SC 1, *Personal safety equipment*.

This third edition cancels and replaces the second edition (ISO 15027-3:2012), which has been technically revised.

The main changes are as follows:

- Terms and conditions have been added;
- in [Clause 4](#), the order of testing has been changed and clarified;
- in [Subclause 4.3](#), a temperature and cycling test procedure for suits stored in sealed storage bags has been added;
- in [Subclause 4.5](#), a test for tensile strength of seams has been added;
- in [Subclause 4.7](#), a buoyancy test has been added;
- in [Subclause 4.8](#), a suit strength test has been added;
- in [Subclause 4.9](#), a lifting loop test has been added;
- in [Subclause 4.12.2](#), the number and sizes of human test subjects have been revised;
- in [Subclause 4.14.1](#), the use of a thermal manikin has been revised;
- [Annex B](#) "Test protocol and checklist for manikin testing" has been added;
- [Annex C](#) "Thermal manikin – Means of circulated water" has been added;
- [Annex D](#) "Correlation of thermal manikin systems" has been added;
- [Annex E](#) "Thermal insulation identification for suit material — Test methods" has been added;

— [Annex F](#) "Medical fitness assessment for human thermal testing in cold water" has been added.

A list of all parts in the ISO 15027 series can be found on the ISO website.

Any feedback or questions on this document should be directed to the user's national standards body. A complete listing of these bodies can be found at www.iso.org/members.html.

iTeh Standards
(<https://standards.itih.ai>)
Document Preview

[ISO/FDIS 15027-3](#)

<https://standards.itih.ai/catalog/standards/iso/9e85b8ea-ab7b-4519-96a4-57b3753b50a6/iso-fdis-15027-3>

Immersion suits —

Part 3: Test methods

1 Scope

This part of ISO 15027 specifies the test methods for constant wear suits and abandonment suits.

Requirements for constant wear suits are given in ISO 15027-1:20xx and requirements for abandonment suits are given in ISO 15027-2:20xx.

2 Normative references

The following documents are referred to in the text in such a way that some or all of their content constitutes requirements of this document. For dated references, only the edition cited applies. For undated references, the latest edition of the referenced document (including any amendments) applies.

EN 590, *Automotive fuels — Diesel — Requirements and test methods*

EN 14225-1:2017, *Diving suits - Part 1: Wet suits - Requirements and test methods*

ISO 811, *Textile fabrics — Determination of resistance to water penetration — Hydrostatic pressure test*

ISO 12402:2020, *(all parts), Personal flotation devices*

ISO 2768-1:1989, *General tolerances; tolerances for linear and angular dimensions without individual tolerance indications*

ISO 12894:2001, *Ergonomics of the thermal environment — Medical supervision of individuals exposed to extreme hot or cold environments*

ISO 13935-2, *Textiles — Seam tensile properties of fabrics and made-up textile articles — Part 2: Determination of maximum force to seam rupture using the grab method*

ISO 15027-1:20xx, *Immersion suits — Part 1: Constant wear suits, requirements including safety*

ISO 15027-2:20xx, *Immersion suits — Part 2: Abandonment suits, requirements including safety*

ISO 15831:2004, *Clothing - Physiological effects - Measurement of thermal insulation by means of a thermal manikin*

3 Terms and definitions

For the purposes of this document, the following terms and definitions apply.

3.1

immersion suit

suit designed to protect the user's body from the cooling effects of immersion in water

Note 1 to entry: Cooling effects include cold shock (3.21) and hypothermia (3.14).

[SOURCE: ISO 15027-1:20xx, 3.1]

3.2

constant wear suit

immersion suit designed to be routinely worn for activities on or near water in anticipation of immersion in water, but permitting physical activity to such an extent that actions can be undertaken without undue encumbrance and thus, head, hands and feet need not be covered

[SOURCE: ISO 15027-1:20xx, 3.2]

3.3

abandonment suit

immersion suit including head, hand and feet protection designed to permit rapid donning in the event of an imminent immersion in water

[SOURCE: ISO 15027-1:2012, 3.3]

3.4

secondary suit closure

additional closure which can be operated by the user to enhance the fit of the suit

[SOURCE: ISO 15027-1:20xx, 3.7]

3.5

exterior fabric

outer fabric of a suit, either in the form of a single or composite fabric

[SOURCE: ISO 15027-1:20xx, 3.9]

3.6

retro-reflective material

material that reflects light beams back to their point of origin

[SOURCE: ISO 15027-1:20xx, 3.10]

3.7

buddy line

length of cord which can be tied or otherwise fixed to another person, or to that person's personal flotation device or other objects, so as to keep a user in the vicinity of that person or object with a view to making location and thus rescue easier

[SOURCE: ISO 15027-1:20xx, 3.12]

3.8

clo

unit to express the relative thermal insulation values of various clothing assemblies

Note 1 to entry: One clo is equal to $0,155 \text{ Km}^2 \text{ W}^{-1}$.

[SOURCE: ISO 15027-1:20xx, 3.13]

3.9

hypothermia

condition where body core temperature is below $35 \text{ }^\circ\text{C}$

[SOURCE: ISO 15027-1:20xx, 3.14]

3.10

helicopter transit suit

constant wear suit worn by helicopter occupants

[SOURCE: ISO 15027-1:20xx, 3.16]

3.11**suit system**

suit system

immersion suit including its components and accessories, and any auxiliary buoyancy or PFD

Note 1 to entry: Storage bag is not part of the suit system.

3.12**underclothing**

clothes worn under the suit system

[SOURCE: ISO 15027-1:20xx, 3.19]

3.13**cold shock**

short transitory phase lasting about 2 to 3 min upon sudden immersion in cold water and characterized by an uncontrollable hyperventilation accompanied by other cardio-respiratory distress

[SOURCE: ISO 15027-1:20xx, 3.21]

3.14**personal flotation device****PFD**

garment or device which, when correctly worn and used in water, provides the user with a specific amount of buoyancy which increases the likelihood of survival

4 Testing of the device**4.1 General**

Requirements, for which no special test methods are given in this document, shall be tested in one of the following ways:

- a) by tests referred to in ISO 15027-1 and ISO 15027-2; or
- b) by measurement; or
- c) by visual assessment; or
- d) by functional test.

Prior to testing, materials and components shall be conditioned for $(24 \pm 0,1)$ h under standard atmosphere. The temperature cycling test and the rotating shock bin test shall be carried out as preconditioning before any other tests are carried out.

4.2 Sampling

Where materials and components are common to a range of suits, it is permitted to test just one sample of each material or component, unless specified otherwise by the relevant test procedure.

4.3 Temperature cycling test**4.3.1 General**

The temperature cycling test shall be carried out as a preconditioning before all other tests.

4.3.2 Procedure

The suit, along with any attachments, shall be subjected to the following exposures with the suit packed in accordance with the manufacturer's instructions..

If the suit is to be supplied in a sealed storage bag such as hermetically sealed or vacuum packed, the **suit** samples shall be exposed to this test in this condition, including the storage method.

The suit shall be subjected to 10 alternating cycles of 8 h continuous exposures to temperatures of $(65 \pm 2) ^\circ\text{C}$ and $(-30 \pm 2) ^\circ\text{C}$. These alternating temperatures need not follow immediately after each other. On completion of the temperature cycling test, the suit shall be visually inspected for signs of degradation to the materials or construction or to any attachments.

4.4 Rotating shock bin test

4.4.1 General

The rotating shock bin test shall be carried out as a preconditioning after the temperature cycling test in [3.3](#) but before all other tests.

4.4.2 Apparatus

The equipment used shall be that shown in [Figure 1](#), consisting of a box of specific design made from plywood board or equivalent, the inside surface of which shall be coated with hard plastic laminate or similar. The bearing of the bin shall be in the centre of the mass and permit the bin to be rotated freely.

4.4.3 Procedure

Place the suit in the shock bin through a flush panel in one of the shock bin's faces, then close and secure it. The shock bin shall be operated for a total of 150 rotations at a steady rate of 6 rotations per minute.

4.4.4 Evaluation

On completion of the rotations, the suit shall be removed from the shock bin and examined by the panel for signs of wear and tear, and for any signs that the thermal insulation material has migrated.

Dimensions in millimetres

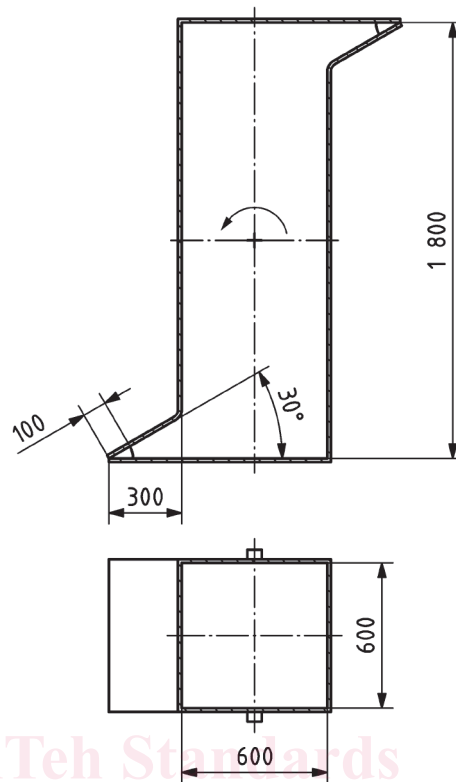

NOTE In this figure, dimensions are identical once rotated 180° on its central axis.

Figure 1 — Design of rotation shock bin apparatus

4.5 Tensile strength of seams [ISO/FDIS 15027-3](https://standards.iteh.ai/catalog/standards/iso/9e85b8ea-ab7b-4519-96a4-57b3753b50a6/iso-fdis-15027-3)

The tensile strength of seams shall be measured on separate samples using the grab method given in ISO 13935-2, using specimens of at least 60 mm width and with at least 100 mm of material on each side of the test point, with four similar seams for each type of seam including the seam between fastening devices, including zip fasteners, and fabric

4.6 Fuel resistance test

Place three samples each of all exterior fabrics, typical seams, apertures and components in a suitable container and submerge them under a 100 mm head of diesel according to EN 590 at a temperature of $(20 \pm 2) ^\circ\text{C}$ for 24 h. After removal from the container, remove the surface oil by wiping. Subject the samples to a hydrostatic test according to ISO 811 with a speed of 10 cm/min until 1 000 mm water head and then carry out a tensile seam strength test according to [3.5](#).

4.7 Buoyancy test

4.7.1 Principle

The buoyancy of a suit that is designed to be used without a PFD shall be measured using Archimedes' principle of weighing the submerged device in water, as specified below.

Any inflatable chambers required to meet ISO 15027-2:20xx, 4.11.8 shall be inflated.

The buoyancy loss of the suit shall be measured and recorded after entrapped air has been removed and 24 h after the initial buoyancy has been measured.

4.7.2 Apparatus

The standard equipment required consists of:

- a) a weighted cage, whose submerged weight is greater than 1,1 times its expected buoyancy value, and
- a) a tank of fresh water deep enough to accommodate the device horizontally with its upper surface at a depth of 100 mm to 150 mm below the water surface without contacting the sides of the tank or the bottom and supported by a calibrated load cell or balance.

4.7.3 Procedure

The suit shall be enclosed in the weighted cage.

The cage shall be suspended from the load cell in fresh water at a temperature of (20 ± 5) °C so that the upper surface of the horizontally positioned suit is submerged at 100 mm to 150 mm below the surface. The immersed combined weight shall be recorded as A.

The assembly shall remain immersed for $(24,0 + 0,5 - 0)$ h, after which time the combined weight shall again be recorded as B.

The suit shall finally be removed from the cage. The weighted cage shall again be immersed and the result again recorded as C.

The water temperature, air temperature, and atmospheric pressure shall be recorded at the start of each test and then after completion of each test.

4.7.4 Results

The buoyancy values shall be corrected to a temperature of 20 °C and an atmospheric pressure of 101,325 kPa.

The initial buoyancy is obtained by subtracting A from C. The final buoyancy is obtained by subtracting B from C. The buoyancy lost during immersion is obtained by subtracting the final buoyancy from the initial buoyancy.

4.8 Suit strength test

4.8.1 Principle

The suit shall be subject to tension via its integral structure, such as waist belt or harness arrangement, by means of a specified load.

4.8.2 Apparatus

The apparatus consists of a horizontally suspended upper cylinder, of diameter (50 ± 5) mm for child suits, or of diameter (125 ± 10) mm for adult suits. The length of the test cylinder shall be sufficient to accommodate the full width of the portion of the suit under test, as shown in [Figure 2](#).

4.8.3 Procedure

The suit shall withstand a load of 1 350 N for 30 minutes, without tearing, seams ripping, parts breaking, or other damage that permits water entry or otherwise affect the intended performance of the suit. One sample of the suit is to be tested. Prior to the application of the load, the suit is to be immersed in water for at least 2 minutes. The suit is to be placed in the test apparatus immediately after the immersion.

The load is to be applied by means of two cylinders, as illustrated in [Figure 2](#).

With the suit supported by the top cylinder and the primary closures of the suit closed and adjusted to simulate use, a weight is to be attached to the bottom cylinder by means of ropes or cables to apply the required load to the suit. When required, to accommodate the test apparatus, the suit is to be cut at the wrists or waist, or holes are to be cut into the suit.

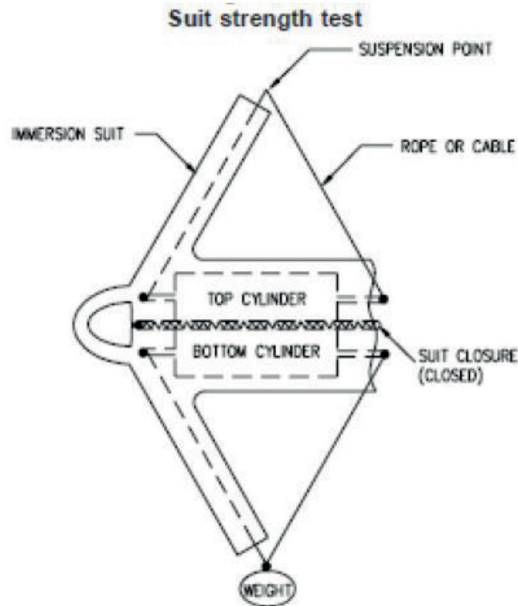

Figure 2 — Suit strength test

4.8.4 Results

The suit shall be examined for any failures resulting in functional damage of the suit.

4.9 Lifting loop test

4.9.1 Procedure

The suit shall be fitted to the appropriately sized dummy such as that shown in ISO 12401:2009, 5.2.2.1 or the appropriately sized test form (see [Figure 3](#)) according to the manufacturer's donning and adjustment instructions.

A cylinder (50 ± 5) mm in diameter, shall be put through the loop and a load of 3 200 N shall be applied steadily until the suit is hanging freely. The load shall be maintained for 30 minutes and shall include the weight of the dummy or test form (see [Figure 3](#)).

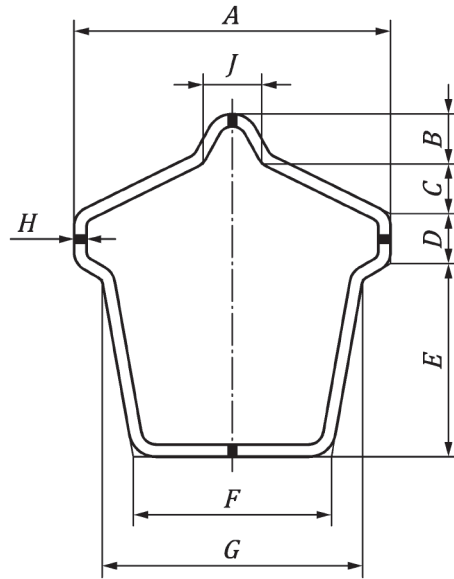

Key

Dimensions in millimeters

| Size | A | B | C | D | E | F | G | H | I |
|--------|-----|------|------|------|-----|-----|-----|------|------|
| Adult | 610 | 114 | 76,2 | 127 | 381 | 432 | 508 | 25,4 | 178 |
| Child | 508 | 102 | 76,2 | 102 | 279 | 330 | 406 | 22,2 | 152 |
| Infant | 305 | 63,5 | 38,1 | 63,5 | 191 | 203 | 241 | 19,1 | 76,2 |

Figure 3 — Test form for vertical load test, lifting loop and buddy lines

Note General tolerances ISO 2768-1:1989, tolerance level "v".

4.9.2 Results

The suit and lifting loop shall be examined for any failures resulting in functional damage of the suit.

4.10 Flammability test

4.10.1 Principle

The test suit system is passed over a test pan with burning test fuel to determine if the suit system burns or continues to melt after removal.

4.10.2 Apparatus

Test pan, (300 ± 20) mm × (350 ± 20) mm × (65 ± 5) mm.

Test fuel: petrol or n-heptane.

4.10.3 Sampling

One suit system shall be subjected to the flammability test.