



## Standard Practice for Sampling Steam<sup>1</sup>

This standard is issued under the fixed designation D1066; the number immediately following the designation indicates the year of original adoption or, in the case of revision, the year of last revision. A number in parentheses indicates the year of last reapproval. A superscript epsilon ( $\epsilon$ ) indicates an editorial change since the last revision or reapproval.

### 1. Scope

1.1 This practice covers the sampling of saturated and superheated steam. It is applicable to steam produced in fossil fired and nuclear boilers or by any other process means that is at a pressure sufficiently above atmospheric to establish the flow of a representative sample. It is also applicable to steam at lower and subatmospheric pressures for which means must be provided to establish representative flow.

1.2 For information on specialized sampling equipment, tests or methods of analysis, reference should be made to the *Annual Book of ASTM Standards*, Vols 11.01 and 11.02, relating to water.

1.3 The values stated in SI units are to be regarded as standard. The values given in parentheses are for information only.

1.4 *This standard does not purport to address all of the safety concerns, if any, associated with its use. It is the responsibility of the user of this standard to establish appropriate safety and health practices and determine the applicability of regulatory limitations prior to use.*

### 2. Referenced Documents

2.1 *ASTM Standards:*<sup>2</sup>

A269 [Specification for Seamless and Welded Austenitic Stainless Steel Tubing for General Service](#)

A335/A335M [Specification for Seamless Ferritic Alloy-Steel Pipe for High-Temperature Service](#)

D1129 [Terminology Relating to Water](#) ~~D1192~~ [Guide for Equipment for Sampling Water and Steam in Closed Conduits](#)

D3370 [Practices for Sampling Water from Closed Conduits](#)

D5540 [Practice for Flow Control and Temperature Control for On-Line Water Sampling and Analysis](#)

### 3. Terminology

3.1 *Definitions:*

3.1.1 For definitions of terms used in this practice, refer to definitions given in Practice D1129.

3.2 *Definitions of Terms Specific to This Standard:*

3.2.1 ~~isokinetic sampling (representative sampling)~~ isokinetic sampling, *n*—a condition wherein the sample entering the port (tip) of the sampling nozzle has the same as the velocity vector (velocity and direction) as the stream being sampled. Isokinetic sampling ensures a representative sample of dissolved chemicals, solids, particles, chemicals absorbed on solid particles, and in the case of saturated and wet steam, water droplets are obtained.

3.2.2 ~~sample cooler~~ sample cooler, *n*—a small heat exchanger designed to provide cooling/condensing of small process sampling streams of water or steam.

3.2.3 ~~sampling~~ sampling, *n*—the withdrawal of a representative portion of the steam flowing in the boiler drum lead or pipeline by means of a sampling nozzle and the delivery of this portion of steam in a representative manner for analysis.

3.2.4 ~~saturated steam~~ saturated steam, *n*—a vapor whose temperature corresponds to the boiling water temperature at the particular existing pressure.

3.2.5 ~~superheated steam~~ superheated steam, *n*—a vapor whose temperature is above the boiling water temperature at the particular existing pressure.

<sup>1</sup> This practice is under the jurisdiction of ASTM Committee D19 on ~~Water~~ and is the direct responsibility of Subcommittee D19.03 on Sampling Water and Water-Formed Deposits, Analysis of Water for Power Generation and Process Use, On-Line Water Analysis, and Surveillance of Water.

Current edition approved Dec. 15, 2006. Published January 2007. Originally approved in 1949. Last previous edition approved in 2001 as D1066-97 (2001). DOI: 10.1520/D1066-06.

Current edition approved June 15, 2011. Published July 2011. Originally approved in 1949. Last previous edition approved in 2006 as D1066-06. DOI: 10.1520/D1066-11.

<sup>2</sup> For referenced ASTM standards, visit the ASTM website, [www.astm.org](http://www.astm.org), or contact ASTM Customer Service at [service@astm.org](mailto:service@astm.org). For *Annual Book of ASTM Standards* volume information, refer to the standard's Document Summary page on the ASTM website.

**4. Summary of Practice**

4.1 This practice describes the apparatus, design concepts and procedures to be used in extracting and transporting samples of saturated and superheated steam. Extraction nozzle selection and application, line sizing, condensing requirements and optimization of flow rates are all described. Condensed steam samples should be handled in accordance with Practices D3370 and D5540, and Guide D1192.

**5. Significance and Use**

5.1 It is essential to sample steam representatively in order to determine the amount of all impurities (dissolved chemicals, solid particles, chemicals absorbed on solid particles, water droplets) in it (1).<sup>3</sup> An accurate measure of the purity of steam provides information, which may be used to determine whether the purity of the steam is within necessary limits to prevent damage or deterioration (corrosion, solid particle erosion, flow-accelerated corrosion, and deposit buildup) of downstream equipment, such as turbines. Impurities in the steam may be derived from boiler water carryover, inefficient steam separators, natural salt solubility in the steam and other factors. The most commonly specified and analyzed parameters are sodium, silica, iron, copper, and cation conductivity.

**6. Interferences**

6.1 *Saturated Steam*— Sampling of steam presents difficult extraction and transport problems that affect the representativeness of the sample.

6.1.1 Isokinetic sampling requires that the velocity vector (velocity and direction) of the fluid entering the sample nozzle port (tip) be the same as the steam being sampled at the location of the sample nozzle. When the sample is not extracted isokinetically the contaminants in the steam are not properly represented in the sample. The effects of non-isokinetic sampling are illustrated in Fig. 1 and can make the sample unrepresentative. The sample should be removed at a position away from the pipe wall, located at a point of average velocity which can be calculated for both laminar and turbulent flows.

6.1.2 Traditionally, saturated steam samples with initial steam velocities above 11 m/s (36 ft/s) were considered to provide adequate turbulent flow to ensure transport of most particulates and ionic components. More recent studies (2,3) found that because many sample lines are long and uninsulated, steam samples are frequently fully condensed prior to reaching the sample station. Partially or fully condensed samples usually have a velocity too low to prevent excessive deposition and the sample becomes nonrepresentative of the source. Detailed design of the sample line to control vapor and liquid velocity can minimize this interference but cooling of saturated steam samples at the source is recommended to assure a representative sample. See Practices D3370 and D5540 for further information on factors that affect liquid sample transport.

6.2 *Superheated Steam*—Most contaminants can be dissolved in superheated steam. However, as steam pressure and temperature are reduced the solubility of many contaminants is decreased and the contaminants precipitate and deposit on the inner

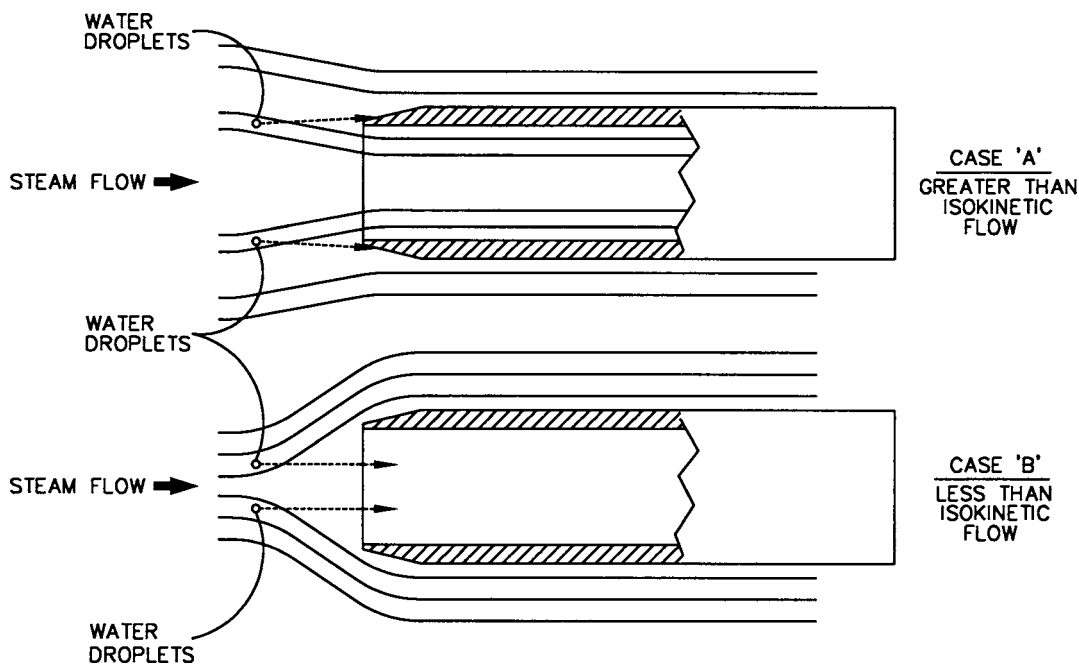

FIG. 1 Effect of None-Isokinetic Sampling

<sup>3</sup> The boldface numbers given in parentheses refer to a list of references at the end of this standard.

surfaces of the sample line (4). This condition has been found to be prevalent only in regions of dry wall tube where the temperature of the tube wall exceeds the saturation temperature of the steam.

6.2.1 Interference also occurs when the transport tube temperature is at or below the saturation temperature. The steam loses superheat and dissolved contaminants deposit on the tube wall. The sample is no longer representative. Superheated steam samples shall be cooled or desuperheated in the sample nozzle or immediately after extraction to ensure a representative sample. Cooling the sample within the sample nozzle may cause thermal fatigue. All necessary precautions should be taken. See 7.1.3.4 and 7.2.4.

## 7. Materials and Apparatus

### 7.1 Extracting the Sample:

7.1.1 *Saturated Steam*—Since saturated steam is normally sampled as a two-phase fluid, made up of steam and small droplets of water, isokinetic sampling shall be employed. Since steam velocities vary with boiler load it normally is not practical to sample isokinetically throughout the load range. Normally, the load of interest is full load or a guaranteed overload. The sampling system shall be designed to provide isokinetic sampling at this design load.

7.1.1.1 At low velocities, the moisture in wet steam forms a film along the inside surface of the steam line that entrains impurities (5). Samples should be extracted at a position away from the pipe wall (Fig. 2). See 7.1.3.1.

7.1.2 *Superheated Steam*—Particulates are often present in superheated steam and these particulates can contain soluble species (Na, Cl, SO<sub>4</sub>) that are of interest and should be sampled (1,6,7). Therefore, an isokinetic sampling nozzle should be used for sampling superheated steam in order to obtain a representative sample of both the gas and solid phases.

7.1.2.1 Because the dissolved contaminants in high pressure superheated steam deposit on the inner surfaces of the nozzle and sample lines as the sample desuperheats, superheated steam samples shall be rapidly desuperheated or condensed near the point of extraction. See 7.2.4.

7.1.3 *Sampling Nozzles*—Stratification of suspended solids in horizontal steam pipes can influence the composition of the steam samples. To minimize the effects of stratification it is recommended that steam sampling nozzles be located in long vertical pipes. To ensure that all water droplets are carried in the flow stream, downward flow is preferred. Nozzles which must be located in a horizontal pipe should be near the top of the pipe (2,7). Ideally, the nozzle should be installed at least 35 internal pipe diameters downstream and 4 internal pipe diameters upstream of any flow disturbance (elbow, tee, valve, orifice, etc.). If this is not possible, the nozzle should be installed so that the ratio of its distance from the upstream disturbance to the downstream disturbance is about 9:1.

7.1.3.1 Nozzles are most frequently located at a distance from the pipe wall where the actual velocity equals the average velocity under laminar flow, typically 0.12 times the pipe inner diameter (Fig. 2) (1,2,7). This also ensures that the sample is extracted from a flow region removed from the pipe inner surface.

7.1.3.2 *Sampling Nozzles for Superheated Steam*—The nozzles described for use with saturated steam can also be used for superheated steam.

7.1.3.3 In order to minimize the deposition of contaminants from superheated steam, some experts recommended injecting condensed and cooled sample directly into the superheated steam sampling nozzle (2). This rarely used method may induce thermal stresses and all necessary precautions should be taken and the nozzle should be periodically inspected for cracking. An acceptable alternative is to condense the sample immediately after extraction. See 7.2.4 for sample line and condensing design criteria.

7.1.3.4 *Design, Materials, and Installation*—Sampling nozzles shall be adequately supported and shall be designed according to applicable codes to prevent failure due to flow-induced vibration, thermal stress, and other possible causes (8). A conical shape rather than cylindrical will reduce the effects of vortex shedding, which can lead to fatigue failures. Strength of the attachment to the pipe must also be considered. Nozzles are most often made of AISI 316 (9) or other austenitic stainless steels or superalloys (1,2,7). Weld joints used for dissimilar metals are subject to high thermal stresses due to different coefficients of thermal expansion. Care should be used in weld rod selection and inspection of all weld joints.

7.1.3.5 Sample port (tip) shall be drilled cleanly, using the standard drill size nearest to the calculated port diameter. The smallest recommended port diameter is 3.18 mm (1/8 in.). Port diameters of less than 2.38 mm (3/32 in.) are subject to plugging and

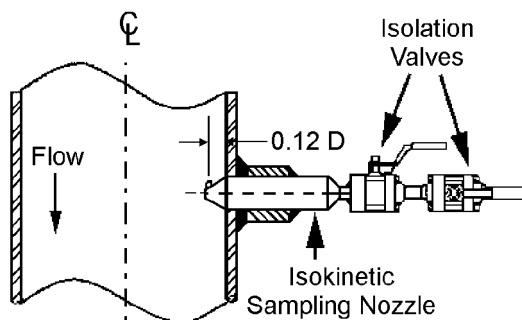

D = Inner Pipe Diameter

FIG. 2 Isokinetic Sampling Nozzle