



Designation: ~~D2765-01 (Reapproved 2006)~~ Designation: D2765 – 11

Standard Test Methods for Determination of Gel Content and Swell Ratio of Crosslinked Ethylene Plastics¹

This standard is issued under the fixed designation D2765; the number immediately following the designation indicates the year of original adoption or, in the case of revision, the year of last revision. A number in parentheses indicates the year of last reapproval. A superscript epsilon (ϵ) indicates an editorial change since the last revision or reapproval.

1. Scope*

1.1 The gel content (insoluble fraction) produced in ethylene plastics by crosslinking ~~can be~~ is determined by extracting with solvents such as decahydronaphthalene or xylenes. ~~Such extraction test—The methods are described herein. They~~ herein are applicable to crosslinked ethylene plastics of all densities, including those containing fillers, and all provide corrections for the inert fillers present in some of those compounds.

1.2 Test Method A, which permits most complete extraction in least time, is to be used for referee tests, but two alternative nonreferee Test Methods B and C are also described. ~~The first of these—Test Method B~~ differs from the referee test method only in sample preparation; that is, it requires use of shavings taken at selected points in cable insulation, for example, rather than the ground sample required by the referee test method. Because the shaved particles are larger, less total surface per sample is exposed to the extractant, so this test method ordinarily yields extraction values about 1 to 2 % lower than the referee method. ~~The second of the alternative test methods—Test Method C~~ requires that a specimen in one piece be extracted in xylenes at a constant temperature of 110°C. At this temperature and with a one-piece specimen, even less extraction occurs (from 3 to 9 % less than the referee test method) ~~but~~ method), this method permits swell ratio (a measure of the degree of crosslinking in the gel phase) can be determined.

1.3 Extraction tests ~~can be~~ are made on articles of any shape. They have been particularly useful for electrical insulations since specimens may be selected from those portions of the insulation most susceptible to insufficient crosslinking.

1.4 The values stated in SI units are to be regarded as standard. The inch-pound units in brackets are for information only.

NOTE 1—ISO 10147 is similar to this test, but is not equivalent. 1—Method B of this test method is equivalent to ISO 10147.

1.5 *This standard does not purport to address all of the safety concerns, if any, associated with its use. It is the responsibility of the user of this standard to establish appropriate safety and health practices and determine the applicability of regulatory limitations prior to use.* Specific precautionary statements are given in Sections 6, 10, and 25.

2. Referenced Documents

2.1 ASTM Standards:²

D297 Test Methods for Rubber Products Chemical Analysis

D618 Practice for Conditioning Plastics for Testing

D883 Terminology Relating to Plastics

D1603 Test Method for Carbon Black Content in Olefin Plastics

D1998 Specification for Polyethylene Upright Storage Tanks

D3351 Test Method for Gel Count of Plastic Film

E691 Practice for Conducting an Interlaboratory Study to Determine the Precision of a Test Method

2.2 ISO Standard:

ISO 10147 Pipes and Fittings Made of Crosslinked Polyethylene (Pe-X)—Estimation of the Degree of Crosslinking by Determination of the Gel Content

3. Terminology

3.1 Definitions of Terms Specific to This Standard:

¹ These test methods are under the jurisdiction of ASTM Committee D20 on Plastics and are the direct responsibility of Subcommittee D20.15 on Thermoplastic Materials. Current edition approved April 1, 2006. Published April 2006. Originally approved in 1968. Last previous edition approved in 2001 as D2765-01. DOI: 10.1520/D2765-01R06.

Current edition approved Sept. 1, 2011. Published September 1, 2011. Originally approved in 1968. Last previous edition approved in 2006 as D2765-01(2006). DOI: 10.1520/D2765-11.

² For referenced ASTM standards, visit the ASTM website, www.astm.org, or contact ASTM Customer Service at service@astm.org. For Annual Book of ASTM Standards volume information, refer to the standard's Document Summary page on the ASTM website.

*A Summary of Changes section appears at the end of this standard.

3.1.1 *gel content*—the percentage by mass of polymer insoluble in a specified solvent after extraction under the specified conditions.

3.1.2 *soluble*—capable of being loosened or dissolved, susceptible of being dissolved in or as if in a fluid. (See Webster's Ninth New Collegiate Dictionary, 1988.)

3.1.3 *swell ratio*—the ratio of the gel volume in the swollen state to its volume in the unswollen state.

3.2 Terms as shown in Terminology D883 are applicable to this test method.

4. Summary of Test Methods

4.1 Specimens of the crosslinked ethylene plastic are weighed and then immersed in the extracting solvent at the temperature specified by the procedure selected and for the time designated by that procedure. After extraction, the specimens are removed, dried, and reweighed as directed. The amount of material extracted is calculated and, if desired, swell ratio also may be determined by the means described in alternative Test Method C.

5. Significance and Use

5.1 Many important properties of crosslinked ethylene plastics vary with the gel content. Hence, determination of the gel content provides a means of both controlling the process and rating the quality of finished products.

5.2 Extraction tests permit verification of the proper gel content of any given crosslinked ethylene plastic and they also permit comparison between different crosslinked ethylene plastics, including those containing fillers, provided that, for the latter, the following conditions are met:

5.2.1 The filler is not soluble in either decahydronaphthalene or xylenes at the extraction temperature.

5.2.2 The amount of filler present in the compound either is known or can will be determined by other means.

5.2.3 Sufficient crosslinking has been achieved to prevent migration of filler during the extraction. Usually it has been found that, at extraction levels up to 50 %, the extractant remains clear and free of filler.

~~5.3 Since some oxidative degradation of the material can occur at the reflux temperature of the extractants, a~~ 5.3 A suitable antioxidant is added to the extractant to inhibit such degradation. possible oxidative degradation at the extraction temperatures.

5.4 Before proceeding with this test method, reference should shall be made to the specification of the material being tested. Any test specimen preparation, conditioning, dimensions, or testing parameters, or a combination thereof, covered in the materials specification shall take precedence over those mentioned in this test method. If there are no material specifications, then the default conditions apply.

6. Precautions

6.1 This test method measures a much larger three – dimensional polymer network and is different than that measured by Test Method D3351 ~~and should not be confused with it.~~

6.2 It has been reported that ~~crosslinked~~ ultra-high molecular weight polyethylene fails to completely dissolve in this procedure at times. <https://standards.iteh.ai/catalog/standards/sist/a35d6e7b-a61d-4897-8574-96fd15d481be/astm-d2765-11>

7. Conditioning

7.1 *Conditioning*—Condition the test specimens at $23 \pm 2^\circ\text{C}$ [~~73.4~~($73.4 \pm 3.6^\circ\text{F}$)]3.6°F for not less than 40 h prior to test in accordance with Procedure A of Practice D618, for those tests where conditioning is required. In cases of disagreement, the tolerance shall be $\pm 1^\circ\text{C}$ [~~$\pm 1.8^\circ\text{F}$~~]($\pm 1.8^\circ\text{F}$).

7.2 *Test Conditions*—Prepare samples in the standard laboratory atmosphere of $23 \pm 2^\circ\text{C}$ [~~73.4~~($73.4 \pm 3.6^\circ\text{F}$)]3.6°F, unless otherwise specified in the test methods. In cases of disagreement, the tolerance shall be $\pm 1^\circ\text{C}$ [~~$\pm 1.8^\circ\text{F}$~~]($\pm 1.8^\circ\text{F}$).

TEST METHOD A (REFEREE TEST METHOD)

8. Apparatus

8.1 The extraction apparatus shall be of the following general type, as illustrated in Fig. 1:

8.1.1 *Round-Bottom Flask*, with large-mouth ground-glass or cork joint. For one or two determinations at one time, a 500-mL flask is appropriate. For several determinations at one time, but not exceeding six, a 2000-mL flask is suitable.

8.1.2 *Heating Mantle* ~~to fit the flask and with sufficient heating capacity to boil decahydronaphthalene (boiling point 190 to 193°C) or xylenes (boiling point 138 to 141°C).~~ to fit the flask and with sufficient heating capacity to boil decahydronaphthalene.

8.1.3 *Reflux Condenser* with ground-glass or cork joint to fit into flask.

8.1.4 *Ring Stand and Appropriate Clamps.*

8.2 *Grinding Equipment*, suitable for reducing the sample to a fineness between 30 and 60 mesh. A bench-top laboratory mill; is satisfactory, although any procedure which will produce a sample of the required fineness without generating excessive heat may be used. is acceptable.

8.2.1 *U.S. No. 30 and U.S. No. 60 Sieves.*

8.2.2 *U.S. No. 120 Stainless Steel Wire Cloth.*

8.3 *Vacuum Oven*, with vacuum source capable of creating a vacuum of at least 710 mm [~~28 in.~~](28 in.) Hg and equipped with a thermometer capable of measuring to 150°C.

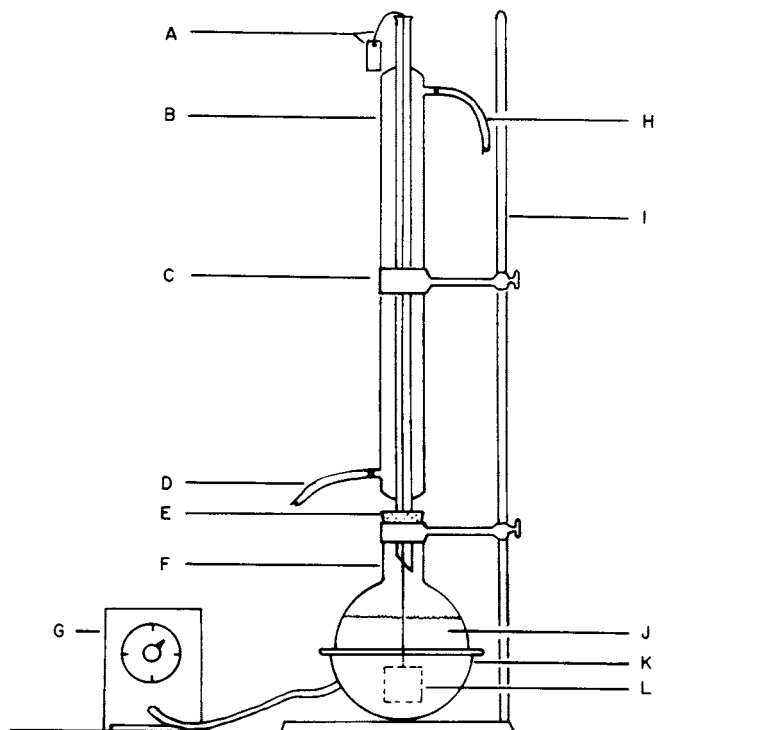

A—Identification tag and fine wire attached to cage.
 B—Reflux condenser.
 C—Ring stand clamp.
 D—Water inlet.
 E—Ground-glass or cork joint.
 F—Large-mouth round-bottom flask.
 G—Variable transformer.
 H—Water outlet.
 I—Ring stand.
 J—Decahydronaphthalene or xylene.
 K—Heating mantle.
 L—120-mesh wire cage containing the specimen.

FIG. 1 Extraction Apparatus

8.4 ~~Analytical Balance, capable of weighing to 0.001 g, capable of weighing to 0.001 g (see also Note 2).~~

NOTE 2—If a slightly higher degree of accuracy is desired (about 1 to 2 %) a modified Soxhlet Extractor, Kontes Catalog No. 586100-0023, Size C, Kontes Glass Co., Vineland, NJ or equivalent Extractor may be employed wherein the specimen is held in an extraction thimble. The extraction thimble, with extra-coarse fritted glass disk sealed in, Kontes 586500-0023, in, will have 45-mm body diameter, 130-mm height or equivalent (height must subsequently be cut to 75 mm). The fritted disk is extra-coarse with fused edge, Kontes 952000-4025, 40-mm diameter or equivalent, edge. Glass wool 13 to 19 mm thick ~~(1/2 to 3/4 in.)~~ will be placed on the bottom of the extraction thimble to support one gram 30–60 mesh ground sample which is covered with 13 to 19 mm thick layer of glass wool, a fritted glass disk and a small glass weight. The extraction thimble assembly rests upon the 55-mm portion of the thimble previously cut off, the latter inserted into the modified Soxhlet Extractor.

9. Reagents

9.1 ~~Decahydronaphthalene~~Decahydronaphthalene (Decalin), anhydrous, boiling point 189 to 191°C.

9.2 Xylenes, ACS reagent grade, boiling point 138 to 141°C.

9.3 ~~2,2'-methylene-bis (4-methyl-6-tertiary butyl phenol)~~4-methyl-6-tertiary butyl phenol) or equivalent, as stabilizer for the solvent.

10. Safety Precautions

10.1 Xylenes and decahydronaphthalene are toxic and flammable solvents and ~~as such should~~ shall be handled carefully. Use only in a ventilated hood. Check the effectiveness of the hood before starting the tests. Do not inhale the vapors. Excessive inhalation of the vapors ~~may~~ has been known to cause dizziness or headache, or both. In the event of excessive inhalation, seek fresh clean air.

11. Test Specimens

11.1 At least two specimens each containing 0.300 ± 0.015 g of ground polymer weighed to the nearest 0.001 g shall be tested.

11.2 The test samples shall be ground to a fineness that will pass through a 30-mesh sieve. Shake this sieved material over a 60-mesh sieve and reject any material that passes through.

11.3 Test specimens originating from insulation cut from wire ~~should~~shall be homogeneous and consist of an equal mixture of samples representative of insulation nearest to the conductor and samples representative of insulation nearest the outer periphery of the construction unless specific portions of the insulation are being examined for insufficient crosslinking.

12. Procedure

12.1 Prepare a specimen holder by cutting a piece of 120-mesh stainless steel cloth measuring approximately 80 by 40 mm ~~{3(3 by 1½ in.}in.)~~. Fold this to form a square measuring approximately 40 mm ~~{(1½ in.}in.)~~. Fold two sides of this square closed by folding the cloth at the edges about 6 to 7 mm ~~{¼ in.}in.)~~ and stapling those folds. In that manner, a pouch open at the top is obtained. Weigh this pouch (W_1).

12.2 Place approximately 0.3 g of the ground and screened sample in the weighed pouch. Weigh the pouch and specimen (W_2). Fold over the open side of the pouch and staple the edge to form a cage. Weigh the cage and sample (W_3).

12.3 Fill a round-bottom flask as described in 8.1.1 with enough solvent to immerse the 120-mesh cage and sample completely during extraction. Three hundred fifty grams in a 500-mL flask or 1000 g in a 2000-mL flask is sufficient. Dissolve 1 % of antioxidant in the decahydronaphthalene or xylenes to inhibit further crosslinking of the specimen.

12.4 Boil the decahydronaphthalene or xylenes vigorously enough to ensure good agitation of the solution. Twenty to 40 drops/min from the condenser, while using 1000 g of solvent, is a satisfactory boiling rate. Suspend the cage and specimen in the solvent so that the bottom edge of the cage is almost touching the bottom of the flask. A small wire, attached to the cage and extending through the reflux condenser ~~can be~~has been used for suspending the cage. Extract the specimen for 6 h in decahydronaphthalene or for 12 h in xylenes.

NOTE 3—Since most of the extraction occurs within less than the specified time, the period of extraction may be shortened for control tests on the basis of experience. If this is done, the time of extraction must be reported. For referee tests, extraction time is to be as specified by this test method.

12.5 After extraction, place the cage and specimen immediately in a vacuum oven preheated to 150°C. Dry the specimen to constant weight under at least 710 mm ~~{28 in.}(28 in.)~~ Hg vacuum. Cool and weigh (W_4). If the compound absorbs moisture, cool the specimen in a desiccator before weighing.

NOTE 4—It has been reported that drying time sometimes can be materially shortened if the cage and sample are cooled for 15 min and then are placed either on a suspended screen or on lint-free absorbent material to remove excess solvent before being put into the vacuum drying oven.

12.6 If extraction tests are regularly made, ~~the apparatus may be left~~ it is acceptable to leave the apparatus assembled and the extracting solvent (containing inhibitor as directed) ~~may be re-used until it darkens~~. However, if there is any doubt about the values obtained with reused extractant, the test ~~should~~shall be repeated with fresh extractant.

NOTE 5—If the modified Soxhlet apparatus is used, the complete thimble assembly containing 1 g of sample is weighed to the nearest ± 0.0001 g before extraction and after vacuum drying.

13. Calculation

13.1 Calculate the solvent extraction in percent as follows:

$$\begin{aligned} \text{Extract, \%} &= (\text{weight lost during extraction}) / \\ &(\text{weight of original specimen} - \text{weight of filler}) \quad (1) \\ &= [(W_3 - W_4) / ((W_2 - W_1) - F(W_2 - W_1))] \times 100 \\ &= [(W_3 - W_4) / ((1 - F)(W_2 - W_1))] \times 100 \end{aligned}$$

where:

W_1 = weight of the pouch (sealed on three sides, one side open),

W_2 = weight of the specimen and the pouch (sealed on three sides, one side open),

W_3 = weight of the specimen and the cage, after being stapled shut,

W_4 = weight of the specimen and the cage after extraction and drying,

F = fraction of filler (which must be insoluble in decahydronaphthalene or xylenes) in the polyethylene compound, and gel content = 100 – percent extract.

NOTE 6—If the fraction of filler in the material is not known, the test methods described in Test Method D1603 or in Test Methods D297, may be used to determine filler content.

14. Report

14.1 Report the following information:

14.1.1 Complete identification of the compound,

14.1.2 Density of the polyethylene in the compound (usually as identified by its supplier),

14.1.3 Weight percent of polyethylene in the compound or filler content (usually as identified by its ~~supplier, although it may be~~ supplier or determined by the test methods identified in Note 6),