



Designation: ~~D3291-97 (Reapproved 2003)~~ Designation: D3291 – 11

Standard Practice for Compatibility of Plasticizers in Poly(Vinyl Chloride) Plastics Under Compression¹

This standard is issued under the fixed designation D3291; the number immediately following the designation indicates the year of original adoption or, in the case of revision, the year of last revision. A number in parentheses indicates the year of last reapproval. A superscript epsilon (ϵ) indicates an editorial change since the last revision or reapproval.

1. Scope*

1.1 This practice determines the compatibility of plasticizers in poly(vinyl chloride) plastics by rating the amount of plasticizer that spews due to compressional stress set up inside a 180° loop bend.

NOTE 1—Ingredients other than plasticizer can spew from a total formulation.

~~1.2~~ 1.2 The text of this practice references notes and footnotes that provide explanatory material. These notes and footnotes (excluding those in tables and figures) shall not be considered as requirements of this practice.

1.3 The values as stated in SI units are to be regarded as the standard. The values in ~~brackets~~parentheses are given for information only.

1.4 *This standard does not purport to address all of the safety concerns, if any, associated with its use. It is the responsibility of the user of this standard to establish appropriate safety and health practices and determine the applicability of regulatory limitations prior to use.*

~~NOTE 2—There are no ISO standards covering the primary subject of this practice.~~ 2—There is no known ISO equivalent to this standard.

2. Referenced Documents

2.1 *ASTM Standards:*²

D883 [Terminology Relating to Plastics](#)

D1600 [Terminology for Abbreviated Terms Relating to Plastics](#)

3. Terminology

3.1 *General*—Definitions are in accordance with Terminology D883 and abbreviations with Terminology D1600, unless otherwise indicated.

4. Summary of Practice

4.1 Test specimens of plasticized poly(vinyl chloride) sheet are bent through an arc of approximately 180°. The inner radius of the bend is equal to the thickness of the specimen. These bent specimens are secured in a jig designed to hold them in the desired conformation. At specified intervals of time, a specimen is removed, bent 360° in the opposite direction, and the former inside of the loop (now the outside) is examined for evidence of plasticizer spew.

5. Significance and Use

~~5.1 Plasticizers may~~ 5.1 It is possible for plasticizers to become less compatible in poly(vinyl chloride) resin when fused compound is subjected to compressive stress.

5.1.1 This test subjects a standard test specimen to a definite deformation and allows qualitative determination of the amount of spew ~~which may occur~~ that is capable of occurring over a period of time.

5.1.2 An apparent decrease in compatibility of plasticizers with subsequent exudation can cause excessive dirt pickup, marring of lacquered or varnished surfaces, sticky feel, and a number of other associated problems.

5.1.3 When a plasticized poly(vinyl chloride) sheet is stressed in compression by bending it through 180°, ~~the stress may be~~

¹ This practice is under the jurisdiction of ASTM Committee D20 on Plastics and is the direct responsibility of Subcommittee D20.15 on Thermoplastic Materials (Section D20.15.07).

Current edition approved July 10, 2003. Published September 2003. Originally approved in 1974. Last previous edition approved in 1997 as D3291-97. DOI: 10.1520/D3291-97R03 on Thermoplastic Materials.

Current edition approved Sept. 1, 2011. Published September 2011. Originally approved in 1974. Last previous edition approved in 2003 as D3291-97 (2003). DOI: 10.1520/D3291-11.

² For referenced ASTM standards, visit the ASTM website, www.astm.org, or contact ASTM Customer Service at service@astm.org. For *Annual Book of ASTM Standards* volume information, refer to the standard's Document Summary page on the ASTM website.

*A Summary of Changes section appears at the end of this standard.

relieved one way to relieve the stress is by migration of the plasticizer from the compressed area (inside of bend) to the area in tension (outside of bend). If these compressive stresses cannot be relieved rapidly by internal migration of plasticizer, then plasticizer will spew. The internal migration of plasticizer will continue and when a deficiency of plasticizer occurs at the compressed area spewed plasticizer will be reabsorbed. ~~Certain~~ It is possible for certain plasticizers ~~may~~ to spew and be reabsorbed quite rapidly. Less compatible plasticizers ~~may spew~~ are capable of spewing early and ~~continue~~ continuing to spew throughout the test. A test of one week's duration is used for screening, while an extended test of seven weeks' duration is used for a complete profile.

NOTE 3—Other test conditions of time, temperature, or relative humidity may be agreed upon between the seller and the purchaser. 3—It is permissible for the seller and the purchaser to agree upon other test conditions of time, temperature, or relative humidity.

6. Apparatus

- 6.1 Bending Test Jig, as shown in Fig. 1.
- 6.2 Cigarette Papers, cut in half to be approximately square.³

7. Specimen Preparation

7.1 Cut test specimens 12.7 by 25.4 mm [$\frac{1}{2}$ by 1 in.] from a plasticized poly(vinyl chloride) sheet 1.9 ± 0.1 mm [$0.075(0.075 \pm 0.005$ in.)] thick, taking care to ensure the long edges are parallel.

NOTE 4—Optimum fusion conditions of temperature and time vary with plasticizer and resin type as well as other additives. The processing conditions must be agreed upon by the seller and the purchaser.

8. Conditioning

8.1 Test specimens shall be conditioned at $23 \pm 2^\circ\text{C}$ [$73.4(73.4 \pm 3.6^\circ\text{F})3.6^\circ\text{F}$] and $50 \pm 5\%$ ~~10 %~~ relative humidity for 24 h prior to testing.

9. Procedure

9.1 Fold the conditioned specimens in half, short ends together and place the loop end in the jig with the spacer bar equal to four times the nominal specimen thickness—7.6 mm [0.300 in.]—as shown in Fig. 2. Leave about 4.75 mm [$\frac{3}{16}$

³ An example of a satisfactory brand is white OCB paper from Reynolds.

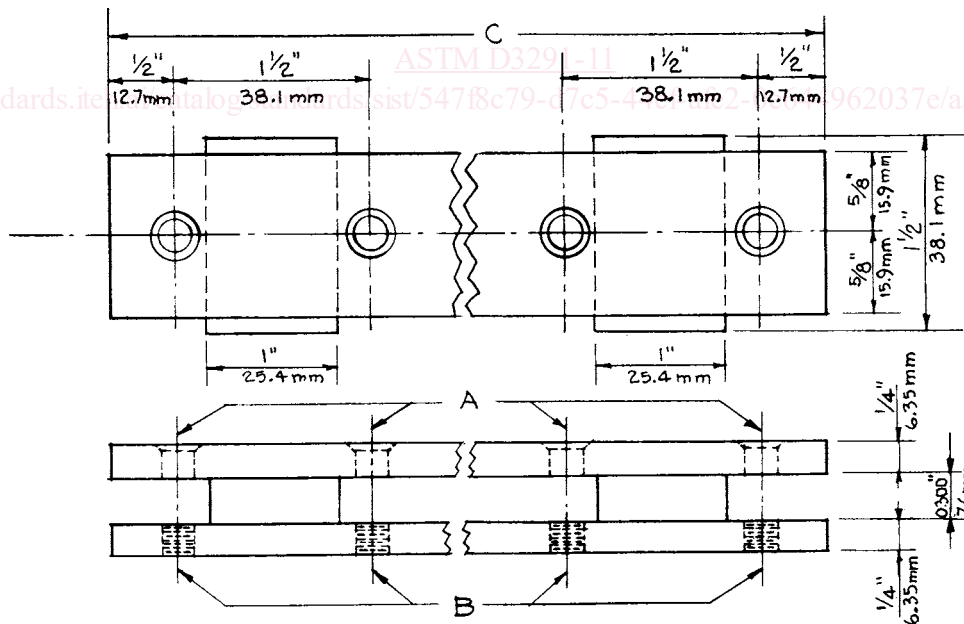

- A Drill and countersink for 6.35-mm [$\frac{1}{4}$ -in.] flat head machine screw
- A Drill and countersink for 6.35-mm ($\frac{1}{4}$ -in.) flat head machine screw
- B Drill and tap to receive 6.35-mm [$\frac{1}{4}$ -in.] machine screw
- B Drill and tap to receive 6.35-mm ($\frac{1}{4}$ -in.) machine screw
- C May be any convenient length up to 457 mm [18 in.]
- C May be any convenient length up to 457 mm (18 in.)

Material—Oil-hardening precision ground tool and die steel

FIG. 1 Bending Test Jig