



## Standard Test Methods for Fire Tests of Roof Coverings<sup>1</sup>

This standard is issued under the fixed designation E108; the number immediately following the designation indicates the year of original adoption or, in the case of revision, the year of last revision. A number in parentheses indicates the year of last reapproval. A superscript epsilon ( $\epsilon$ ) indicates an editorial change since the last revision or reapproval.

*This standard has been approved for use by agencies of the Department of Defense.*

### 1. Scope

1.1 This fire-test-response standard covers the measurement of the relative fire characteristics of roof coverings under simulated fire originating outside the building. It is applicable to roof coverings intended for installation on either combustible or noncombustible decks when applied as intended for use. The following test methods are included:

1.1.1 Intermittent flame exposure test.

1.1.2 Spread of flame test.

1.1.3 Burning brand test.

1.1.4 Flying brand test.

1.1.5 Rain test.

1.2 Three classes of fire test exposure are described:

1.2.1 *Class A Tests* are applicable to roof coverings that are effective against severe test exposure, afford a high degree of fire protection to the roof deck, do not slip from position, and do not present a flying brand hazard.

1.2.2 *Class B Tests* are applicable to roof coverings that are effective against moderate test exposure, afford a moderate degree of fire protection to the roof deck, do not slip from position, and do not present a flying brand hazard.

1.2.3 *Class C Tests* are applicable to roof coverings that are effective against light test exposure, afford a light degree of fire protection to the roof deck, do not slip from position, and do not present a flying brand hazard.

1.3 The values stated in inch-pound units are to be regarded as standard. The values given in parentheses are mathematical conversions to SI units that are provided for information only and are not considered standard.

1.4 *This standard is used to measure and describe the response of materials, products, or assemblies to heat and flame under controlled laboratory conditions, but does not by itself incorporate all factors required for fire hazard or fire risk assessment of the materials, products or assemblies under actual fire conditions.*

1.5 *This standard does not purport to address all of the safety concerns, if any, associated with its use. It is the responsibility of the user of this standard to establish appropriate safety and health practices and determine the applicability of regulatory limitations prior to use.*

1.6 The text of this standard references notes and footnotes that provide explanatory information. These notes and footnotes, excluding those in tables and figures, shall not be considered as requirements of this standard.

### 2. Referenced Documents

2.1 *ASTM Standards:*<sup>2</sup>

D225 Specification for Asphalt Shingles (Organic Felt) Surfaced With Mineral Granules

D226 Specification for Asphalt-Saturated Organic Felt Used in Roofing and Waterproofing

D227 Specification for Coal-Tar-Saturated Organic Felt Used in Roofing and Waterproofing

D312 Specification for Asphalt Used in Roofing

D450 Specification for Coal-Tar Pitch Used in Roofing, Dampproofing, and Waterproofing

D1227 Specification for Emulsified Asphalt Used as a Protective Coating for Roofing

D2178 Specification for Asphalt Glass Felt Used in Roofing and Waterproofing

D2626 Specification for Asphalt-Saturated and Coated Organic Felt Base Sheet Used in Roofing

D2898 Practice for Accelerated Weathering of Fire-Retardant-Treated Wood for Fire Testing

<sup>1</sup> These test methods are under the jurisdiction of ASTM Committee E05 on Fire Standards and are the direct responsibility of Subcommittee E05.14 on External Fire Exposures.

Current edition approved Jan. Sept. 15, 2010-2011. Published February 2010-October 2011. Originally approved in 1955. Last previous edition approved in 2010 as E108 - 10a. DOI: 10.1520/E0108-10A.10.1520/E0108-11.

<sup>2</sup> For referenced ASTM standards, visit the ASTM website, www.astm.org, or contact ASTM Customer Service at service@astm.org. For *Annual Book of ASTM Standards* volume information, refer to the standard's Document Summary page on the ASTM website.

D3018 Specification for Class A Asphalt Shingles Surfaced with Mineral Granules  
 D3158 Specification for Asphalt Saturated and Coated Organic Felt Used in Roofing  
 D3378 Specification for Asphalt-Saturated and Coated Asbestos Felt Base Sheet Used in Roofing  
 D3462 Specification for Asphalt Shingles Made from Glass Felt and Surfaced with Mineral Granules  
 D4442 Test Methods for Direct Moisture Content Measurement of Wood and Wood-Base Materials  
 D4444 Test Method for Laboratory Standardization and Calibration of Hand-Held Moisture Meters

2.2 *UL Standards:*

UL 55A Materials for Built-Up Roof Coverings<sup>3</sup>  
 UL790 Tests for Fire Resistance of Roof Covering Materials<sup>3</sup>

2.3 *NFPA Standards:*

NFPA 256 Tests of Roof Coverings<sup>4</sup>

### 3. Terminology

3.1 *Definitions:* Definitions:

3.1.1 *significant lateral spread*—surface flaming beyond 1-ft. from the lead edge, extending outward to both lateral edges of the test deck assembly or to both inner edges of metal batten strips, if used, along the side edges of the test deck assembly.

3.1.2 *sustained flaming*—any flaming which continues uninterrupted for 5 seconds or more.

3.1.3 *prepared roof covering*—products consisting of shingles, tiles, panels or rolled materials that are typically used for high slope roof applications which are applied directly to the roof deck (usually with one or more layers of underlayment and with or without battens) in accordance with installation instructions supplied with the products.

### 4. Significance and Use

4.1 The test methods described herein are intended to provide a basis for relative comparison of roof coverings. The test methods include simulated fire exposure to the outside of the roof coverings, and, where applicable, a determination as to whether the fire performance characteristics of the roof coverings will be adversely affected by prolonged exposure to rain.

4.2 These test methods measure the surface spread of flame and the ability of the roof covering material or system to resist fire penetration from the exterior to the underside of a roof deck under the conditions of exposure.

4.3 These test methods also provide criteria to determine if the roof covering material will develop flying burning material, identified as flying brands, when subjected to a 12-mph (5.3-m/s) wind during the simulated fire exposure tests.

4.4 These test methods do not necessarily illustrate the expected performance of roof coverings under all actual fire conditions, but they do provide a basis for comparing roof covering materials when subjected to fire sources that are described herein.

4.5 These test methods do not provide any basis for determining the fire resistance characteristics when exposed to a fire originating in the building to which the roofing material is applied.

4.6 The test methods described herein involve calibrating the test equipment using a calibration deck inclined at a slope of 5 in. per horizontal ft (0.416:1). The tests described herein are performed on test decks inclined at slopes up to and including 5 in. per horizontal ft. The severity of the test exposure decreases as the slope of the test deck decreases below 5 in. per horizontal ft.

### 5. Apparatus and Calibration

~~5.1 The essential elements of the fire test apparatus are illustrated in~~

5.1 The essential elements of the fire test apparatus used for tests described in Sections 8-11 are illustrated in Fig. 1. They include a test roof deck *A*, an adjustable frame *B* (see Fig. 2) on which the test roof deck is mounted, a gas burner *C* as a source of flame, a wind tunnel *D*, an air velocity meter with or without the use of a timing device, a gas pressure gage, a control valve, and an adjustable air supply. Control of the shape and size of the flame depends upon minimizing air turbulence in the immediate vicinity of the apparatus. During the test, they consist of the following:

(a) A test deck to which the roof-covering materials to be tested are applied, mounted on a framework. The incline of the framework is to be adjustable with respect to incline (slope) as well as the vertical position for fire testing decks with insulated roof coverings.

(b) A construction of noncombustible boards, mounted on the front of the framework to simulate eaves and cornices.

(c) A gas burner (for intermittent-flame, spread-of-flame and flying brand tests) consisting of a 44-in. (1.12 m) length of nominal 2 in. (2.38 in./60.3 mm OD) pipe having a ½-in. (12.7 mm) wide, 36-in. (0.91 m) long slot in the side toward the test deck. The burner is to be supplied with gas at both ends through nominal 1-in. (1.32 in./33.4 mm OD) pipe to provide uniform gas pressure at the burner assembly.

(d) A blower and air duct for providing the required wind conditions.

(e) Adjustable fins mounted inside the air duct to straighten the air stream and reduce turbulence.

(f) A baffle mounted on the back edge of the test deck to prevent backfiring under the deck.

<sup>3</sup> Available from Underwriters Laboratories Inc., 333 Pfingsten Road, Northbrook, IL 60062.

<sup>4</sup> Available from National Fire Protection Assoc., 1 Batterymarch Park, Quincy, MA 02269.

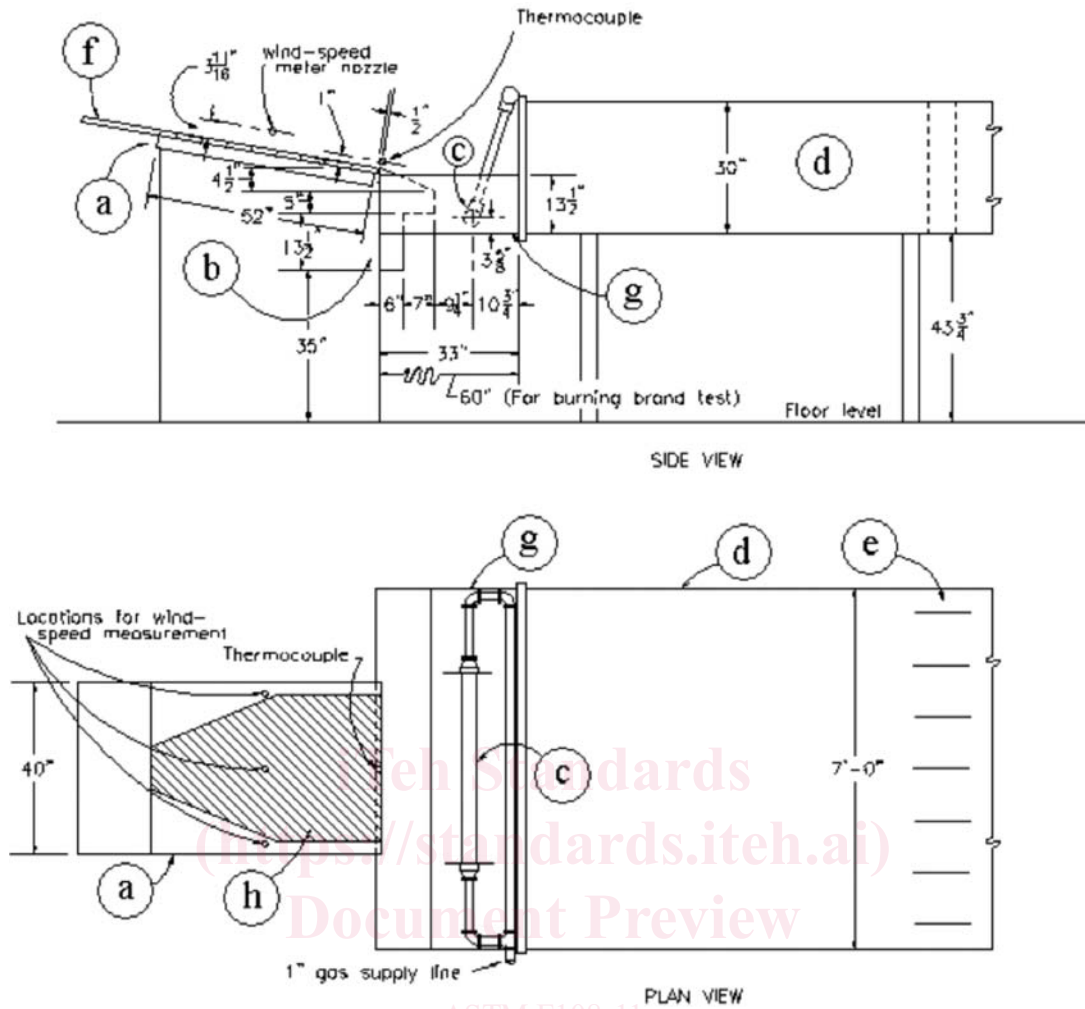

(See Appendix X1 for metric equivalents.)

FIG. 1 Schematic Drawing of Fire Test Apparatus

(g) Noncombustible boards extended from the sides and bottom of the air duct to the simulated-eaves-and-cornices construction mentioned in (b) (not used during burning brand).

(h) Fire calibration exposure pattern – (See 5.5.5).

5.1.1 During the test:

5.1.1.1 Provide free outlet to outside air beyond and above the test apparatus to exhaust air introduced into the test room by the blower, and

5.1.1.2 Close all openings into the test room other than those mentioned in 5.1.1, such as doors and windows.

5.2 The temperature of the air supplied by the blower shall be maintained between 50 and 90°F (10 and 32°C).

5.3 Fig. 3 illustrates the essential elements of the rain test apparatus. illustrates an example of the essential elements of a rain test apparatus.

5.4 Calibrating Air Current:

5.4.1 Set up the test apparatus for the intermittent flame test and position a bare 3-ft, 4-in. by 4-ft, 4 in. (1 m by 1.3 m) plywood, gypsum board or fiber cement board calibration deck on the framework at an incline of 5 in. per horizontal ft (0.416:1).

5.4.2 Measure the air velocity midway up the slope of the calibration deck at its center and 3 in. (76 mm) from each edge.

NOTE 1—Any direct reading instrument with scale graduated in increments of not more than 20 ft/min (6 m/min) or any timed instrument with scale graduated (for a 1 min timed reading) in increments of not more than 5 ft/min (1.5 m/min) will be suitable.

5.4.3 Position the center of the air measuring device  $3\frac{3}{4} \pm \frac{1}{8}$  at a nominal  $3\frac{1}{16}$  in. ( $95 \pm 3$ (94 mm) above the surface. The air flow through and around the instrument shall be as free and undisturbed as possible.

5.4.4 Adjust the air supply system to produce a 1 min timed average velocity of  $1056 \pm 44$  ft/min corresponding to  $12 \pm 0.5$  mph ( $5.3 \pm 0.2$  m/s) at each of the three locations detailed in 5.4.2. In order to comply with 5.5.5, it shall be permitted to adjust the 1-min time averaged velocity at each location by  $\pm 5\%$  from the initial value within the range 1012 to 1100 ft/min (5.1 to 5.5 m/s). This deviation in an individual 1-min timed average velocity shall only be permitted when the average of the 1-min timed

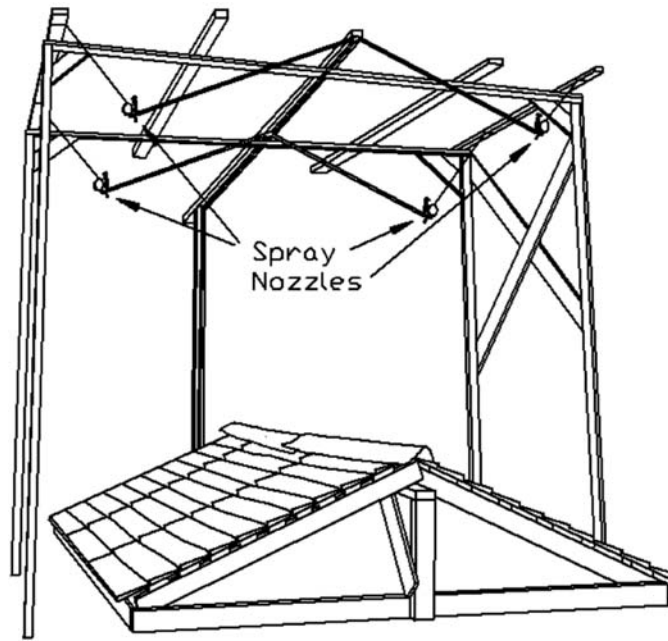

FIG. 2 Rain Test Apparatus

average velocity of all three locations is  $12 \pm 0.5$  mph ( $5.3 \pm 0.2$  m/s).

5.5 *Calibrating Flame Temperature:*

5.5.1 Following the calibration of the air current described in 5.4, position a fiber cement board calibration deck, 4 ft, 4 in. (1.3 m) long on the framework at an incline of 5 in. per horizontal ft (0.416:1).

5.5.2 Measure the temperature with a No. 14 B & S gage (1.63 mm) Type K wire thermocouple located 1 in. (25 mm) above the surface and ½ in. (13 mm) toward the source of the flame from the lower front edge of the calibration deck.

5.5.3 Adjust the gas flow to produce a 2 min average flame temperature of  $1400 \pm 50^\circ\text{F}$  ( $760 \pm 28^\circ\text{C}$ ) for Classes A and B and  $1300 \pm 50^\circ\text{F}$  ( $704 \pm 28^\circ\text{C}$ ) for Class C tests. Allow the response of the thermocouple to the test flame to stabilize before the 2 min average flame temperature is measured. Base the 2 min average on temperatures recorded at 10 s intervals.

NOTE 2—It has been found that the gas flow generally corresponds to a heat supply rate within the range 21 000 to 22 000 Btu/min (369 to 387 kWh) for Class A or B samples and 18 000 to 19 000 Btu/min (316 to 334 kWh) for Class C samples.

5.5.4 Position the top surface of the leading edge of the calibration deck or the test sample flush with the top edge of the simulated eave within a tolerance of  $-0 + \frac{1}{2}$  in. (13 mm).

5.5.5 ~~When these calibration conditions are satisfied, the flame shall be approximately 3 ft (0.9 m) wide at the bottom edge and in the center of the width of the calibration deck and the flame shall gradually narrow to approximately a 6 in. (0.15 m) width in the center of and at the top edge of the calibration deck. Intermittent flashes of flame extending another 1 to 2 ft (0.3 to 0.6 m) beyond the top edge of the deck during flame calibration shall be permitted (see is shown in Fig. 1).~~ Item h. Intermittent flashes of flame extending another 1 to 2 ft (0.3 to 0.6 m) beyond the top edge of the calibration deck shall be permitted.

5.6 *Rain Test Calibration:*

5.6.1 Measure the horizontal projected area over which each nozzle discharges water to the nearest square foot (square metre). Measure the discharge of water for each nozzle for 1 min.

5.6.2 Monitor the total water use during the test (a commercial water meter is suitable for this purpose). For a four day cycle the water usage shall be  $42 \pm 1$  gal/ft<sup>2</sup> ( $1711 \pm 41$  L/m<sup>2</sup>). For a seven day cycle the water usage shall be  $73 \pm 1.7$  gal/ft<sup>2</sup> ( $2975 \pm 71$  L/m<sup>2</sup>).

5.7 *Frequency of Calibration:*

5.7.1 Calibrate the apparatus for air velocity and flame temperature prior to each day's use. Calibrate the apparatus for flame temperature when shifting from Class A or B to Class C tests or vice versa.

5.7.2 Any indication of off-limit condition such as unusual flame appearance or flame contour, excess turbulence, or unusual noise shall be cause for calibration prior to further use.

5.7.3 For the Rain Test, visually check the water flow from each nozzle (for obvious water obstruction in the nozzle and uneven spray pattern) each day during the water cycle and make adjustments when necessary.

5.7.4 For the Rain Test, review the total water flow at the end of each day and at the end of each water cycle. Correct the cause of any off-limit conditions.

6. Preparation of Test Specimens

6.1 Construction of Test Decks:

6.1.1 The test deck for the intermittent flame exposure, burning brand tests, flying brand test, and rain test, except as specified in the following paragraphs, shall be 3 ft-4 in. (1.0 m) wide by 4 ft-4 in. (1.3 m) long and shall be made of No. 1 white pine lumber with not less than 8 % nor more than 12 % moisture content. The lumber shall be free of large or loose knots, sapwood, rot, or pitch pockets, and shall contain no edge knots. Individual deck boards shall be of nominal 1 by 8-in. lumber (S4S). Lay the boards across the shorter dimension of the test deck space  $\frac{1}{4}$  in. (6 mm) apart and securely nail to two nominal 2 by 4-in. wood battens located under and flush with the outer edges of the deck (Fig. 4 Fig. 3). Decks so constructed shall be even and uniform.

6.1.2 Where the roof covering is intended to be installed over other than solid deck, construct the test decks of nominal 1 by 4-in. lumber (S4S) spaced a minimum of  $1\frac{5}{8}$  in. (41 mm) apart and securely nailed to two nominal 2 by 4-in. wood battens. The lumber shall be of the same quality as specified in 6.1.1.

6.1.3 Roof coverings are permitted to be applied to other test decks of the minimum thickness recommended by the manufacturer. This deviation shall be noted in the report. Plywood, if used, shall be exterior Type A-C grade with face and back veneers of Douglas fir conforming to PS1 for softwood plywood and shall be identified as a Group 1 species. Oriented Strand Board (OSB), if used, shall be marked as conforming to PS2. These decks shall have  $\frac{1}{8}$ -in. (3.2-mm) vertical and horizontal joints located as specified in 6.1.1 with all vertical joints centered on nominal 2 by 4-in. wood battens. If wood battens or tongue and groove joints are specified for horizontal joints, this shall be so noted in reporting the tests. The decks for intermittent flame tests shall have a  $\frac{1}{8}$  in. (3.2 mm) metric horizontal joint 8 in. (203 mm) from and parallel to the  $3\frac{1}{3}$  ft (1.0 m) long leading edge. In addition, provide a  $\frac{1}{8}$  in. (3.2 mm) metric vertical joint centered on the deck and extending from the leading edge of the deck to the  $\frac{1}{8}$  in. (3.2 mm) metric horizontal joint. Since the lower  $1\frac{1}{2}$  in. (38 mm) of this joint is not protected by the 2 by 4-in. batten, due to the mounting arrangement on the carriage, cover the underside of this joint from the end of the two-by-four to the leading edge of the deck by a piece of sheet steel, 2 in. (51 mm) wide.

6.1.4 For Classes A and B burning brand tests on decks other than 1 by 8-in. metric nominal lumber, the  $\frac{1}{8}$  in. (3.2 mm) horizontal joint shall be  $22\frac{1}{2}$  in. (572 mm) from and parallel to the leading edge of the deck. Class A test decks shall have a  $\frac{1}{8}$  in. (3.2 mm) metric vertical joint centered on the deck that extends above the horizontal joint. For Class B test decks, provide two

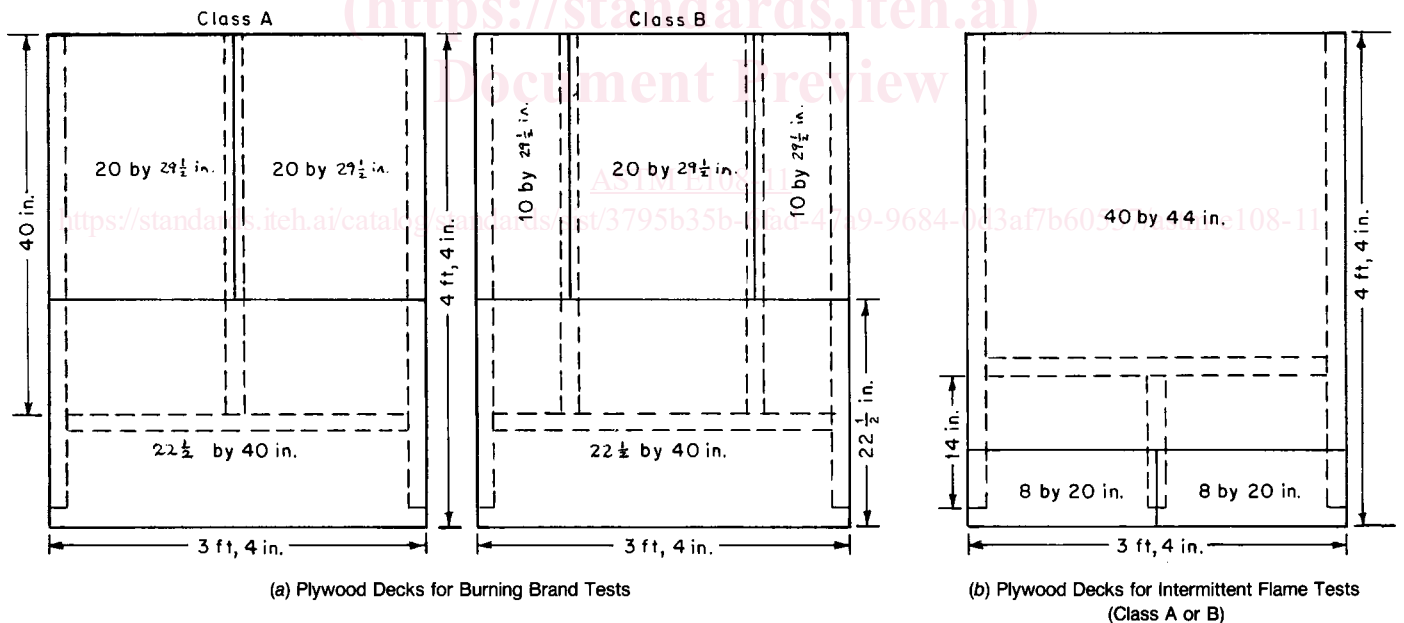

NOTE—Plywood overhangs 2 by 4's by  $1\frac{1}{4}$  at leading edge. 2 by 4 supports are indicated by dotted lines. Plywood joint width:  $\frac{1}{8}$  in.

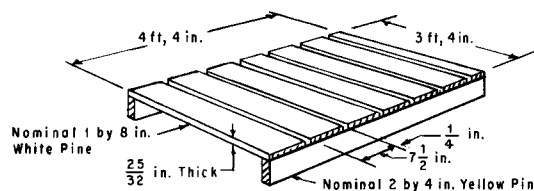

(c) Test Decks for Other than Wood Shingles and Shakes (See Appendix X1 for Metric Equivalents.)

FIG.-4 3 Construction of Test Decks

1/8 in. (3.2 mm) metric vertical joints, extending above the horizontal joint with each vertical joint located 10 in. (254 mm) from and parallel to the edge of the deck. For Class C burning brand test, provide five evenly spaced horizontal joints, with a minimum width of 1/8 in. (3.2 mm) metric between joints in the plywood.

6.1.5 For the spread of flame test, construct the test deck in the same manner as specified for the intermittent flame test, except that (1) the vertical and horizontal joints need not be provided, (2) the length of the deck shall be as specified in 6.1.6 and (3) 15/32-in. (12-mm) thick plywood, conforming to PSI-95, is an acceptable deck for materials or systems when minimal discoloration, without char or no involvement of the plywood test deck occurs, during fire tests. For tests on materials intended for use only on noncombustible decks, a noncombustible deck of the applicable length specified in 6.1.6 is permitted.

6.1.6 The length of the test deck shall be 13 ft (4.0 m) for Class C tests, 9 ft (2.7 m) minimum for Class B tests, and 8 ft (2.4 m) minimum for Class A tests.

6.2 *Application of Roofing on Test Roof Deck*—Apply representative samples of roof covering materials for Class B or C tests to 14 test decks (two each for the spread of flame, intermittent flame, spread of flame, and flying brand tests, four for the burning brand test, and six for the rain test). Apply representative samples of roof covering materials for Class A tests to 16 test decks (two each for intermittent flame, spread of flame, and flying brand tests, four for the burning brand test and six for the rain test). Apply the roof covering materials under investigation in accordance with the manufacturer's instructions and extend to and flush with the edges of the deck, except for a 1-in. (25-mm) overhang at the leading edge. It is permitted to provide an air-seal along the sides of the representative sample of the roof covering material system to restrict air flow under the system during the fire test. The use of a 1-in. (25-mm) maximum width metal batten strip fastened on top of and along each side edge is permitted for mechanically attached single-ply membrane roof covering systems.

NOTE 3—A practice used to provide an air-seal for mechanically attached, fully-adhered and partially-adhered flexible single-ply membrane systems is to pull the membrane taut over the edges of the assembly to fit snugly against the deck and secure it to the wood supports of the test deck.

### 6.3 *Storage and Conditioning of Test Specimens:*

6.3.1 Pieces of any hygroscopic materials from the same stock from which the test deck was constructed shall be tacked to the assembly during construction in such a manner that they are easily removed. These pieces shall be conditioned with the completed assemblies as described in 6.3.2.

6.3.2 The completed test assemblies are to be stored indoors at temperatures not lower than 60°F (16°C) nor higher than 90°F (32°C) for the period of time necessary to cure the assembly components. Test decks are to be stored so that each will be surrounded by freely circulating air.

6.3.3 Just before the deck is tested the pieces of hygroscopic materials prepared in 6.3.1 shall be tested for moisture content. (Notes 4 and 5.)

NOTE 4—Make the moisture determination on two samples from each piece and report the average. For lumber and other wood-based materials, use Test Methods D4442. Use of an appropriately calibrated moisture meter, as described in Test Methods D4444, to determine the moisture content of wood or wood products is also permitted. For other hygroscopic materials, use test methods appropriate for those materials.

NOTE 5—For lumber, the moisture content shall not be less than 8 % nor more than 12 %. For plywood, the moisture content shall not exceed 8 %. For other hygroscopic materials, the moisture shall be within ranges specified by the manufacturer before the assembly is constructed. These specified ranges shall be typical for exposure at 77 ± 9°F (25 ± 5°C) and 55 ± 10 % relative humidity. If there is any indication that the lumber, plywood, or other hygroscopic materials have moisture contents outside these ranges, measure moisture content and replace any out of range materials before building test decks. Out of range pieces shall be dried or rewetted using methods that do not damage the materials.

6.4 The flying brand tests are required when there is a possibility that the roof covering will break into pieces of flying, flaming brands or particles which continue to glow after reaching the floor of the test facility. See Appendix Appendix X3.

## 7. Tests—General

7.1 When a roof covering is restricted for use on noncombustible decks (steel, concrete, or gypsum), only the spread of flame test is required. Materials intended for use only on noncombustible decks are permitted to be tested when applied to a noncombustible deck or any type of combustible deck of the length specified for the spread of flame test.

7.2 When a roof covering is not restricted for use on noncombustible decks, the spread of flame, intermittent flame, and burning brand tests are required.

7.3 The rain tests are required whenever the fire-retardant characteristics of the roof covering materials or construction has the potential to be adversely affected by water. See Appendix X2.

7.4 The weathering tests are required for wood shakes and shingles or when the fire-retardant characteristics of the roof covering materials or construction has the potential to be adversely affected by weathering outdoors.

7.5 The flying brand tests are required when there is a possibility that the roof covering will break into pieces of flaming particles that support combustion on the floor. See Appendix X3.

7.6 In all of the fire tests described in Sections 8-12, trowel noncombustible mortar into the joint formed by the leading edge of the roof covering material and the framework of the carriage. This is to prevent air or the test flame from traveling under the material being tested.

7.7 In these tests subject all decks to an air current as calibrated in 5.4.

7.8 Test prepared roof coverings at a slope of 5 in. per horizontal ft (416 mm per horizontal m). Test built-up roof coverings