**Agricultural irrigation equipment —
Sprinklers —**

**Part 3:
Characterization of distribution and
test methods**

iTeh STANDARD PREVIEW
Matériel agricole d'irrigation — Asperseurs —
(standards.iteh.ai) Partie 3: Caractérisation de la distribution et méthodes d'essai

ISO 15886-3:2021

<https://standards.iteh.ai/catalog/standards/sist/59d51e5b-c1df-45d1-9695-be4d8d08bca8/iso-15886-3-2021>



iTeh STANDARD PREVIEW
(standards.iteh.ai)

ISO 15886-3:2021

<https://standards.iteh.ai/catalog/standards/sist/59d51e5b-c1df-45d1-9695-be4d8d08bca8/iso-15886-3-2021>



COPYRIGHT PROTECTED DOCUMENT

© ISO 2021

All rights reserved. Unless otherwise specified, or required in the context of its implementation, no part of this publication may be reproduced or utilized otherwise in any form or by any means, electronic or mechanical, including photocopying, or posting on the internet or an intranet, without prior written permission. Permission can be requested from either ISO at the address below or ISO's member body in the country of the requester.

ISO copyright office
CP 401 • Ch. de Blandonnet 8
CH-1214 Vernier, Geneva
Phone: +41 22 749 01 11
Email: copyright@iso.org
Website: www.iso.org

Published in Switzerland

Contents

	Page
Foreword	iv
1 Scope	1
2 Normative references	1
3 Terms and definitions	1
4 Collectors	4
4.1 Collector design.....	4
4.2 Collector orientation.....	4
5 Installation of sprinklers under test	5
6 Measurements	6
6.1 Accuracy of measurements.....	6
6.2 Pressure measurement.....	6
6.3 Atmospheric conditions measurements.....	8
6.4 Corrections for evaporative losses within collectors.....	8
7 Collector arrangement, spacing and number	8
7.1 Full grid collector array method.....	8
7.1.1 Method.....	8
7.1.2 Collector spacing.....	8
7.1.3 Sprinkler location relative to grid.....	8
7.2 Radial collector array method.....	9
7.2.1 Method.....	9
7.2.2 Collector spacing.....	9
7.2.3 Location of sprinkler.....	9
7.2.4 Radius of throw.....	9
8 Additional tests	9
8.1 Time of rotation.....	9
8.2 Trajectory height.....	9
9 Test operation	9
9.1 Rotation of sprinkler riser.....	9
9.2 Test duration.....	10
9.3 Other test details.....	10
10 Test location specifications	10
10.1 Indoor testing building specifications.....	10
10.2 Outdoor site specification.....	11
10.2.1 General.....	11
10.2.2 Measurement of atmospheric conditions.....	11
11 Characterization of distribution	11
11.1 Overview.....	11
11.2 Application pattern coverage and uniformity.....	11
11.3 Generating performance measurements from radial arrays.....	12
11.4 Validation of test results.....	12
12 Radius of throw and water distribution curve	12
12.1 General.....	12
12.2 Radius of throw.....	13
12.3 Distribution curve.....	13
12.4 Uniformity of rotation (for rotating sprinklers intended to rotate in a uniform manner).....	14
Annex A (informative) Procedures for the characterization of sprinkler pattern uniformity	15
Annex B (informative) Testing of part-circle sprinklers	19
Bibliography	21

Foreword

ISO (the International Organization for Standardization) is a worldwide federation of national standards bodies (ISO member bodies). The work of preparing International Standards is normally carried out through ISO technical committees. Each member body interested in a subject for which a technical committee has been established has the right to be represented on that committee. International organizations, governmental and non-governmental, in liaison with ISO, also take part in the work. ISO collaborates closely with the International Electrotechnical Commission (IEC) on all matters of electrotechnical standardization.

The procedures used to develop this document and those intended for its further maintenance are described in the ISO/IEC Directives, Part 1. In particular, the different approval criteria needed for the different types of ISO documents should be noted. This document was drafted in accordance with the editorial rules of the ISO/IEC Directives, Part 2 (see www.iso.org/directives).

Attention is drawn to the possibility that some of the elements of this document may be the subject of patent rights. ISO shall not be held responsible for identifying any or all such patent rights. Details of any patent rights identified during the development of the document will be in the Introduction and/or on the ISO list of patent declarations received (see www.iso.org/patents).

Any trade name used in this document is information given for the convenience of users and does not constitute an endorsement.

For an explanation of the voluntary nature of standards, the meaning of ISO specific terms and expressions related to conformity assessment, as well as information about ISO's adherence to the World Trade Organization (WTO) principles in the Technical Barriers to Trade (TBT), see www.iso.org/iso/foreword.html.

This document was prepared by Technical Committee ISO/TC 23, *Tractors and machinery for agriculture and forestry*, Subcommittee SC 18, *Irrigation and drainage equipment and systems*.

This third edition cancels and replaces the second edition (ISO 15886-3:2012), which has been technically revised. It also incorporates the Amendment ISO 15886-3:2012/Amd 1:2016.

The main changes compared to the previous edition are as follows:

- the definitions have been updated;
- the following test methods have been changed:
 - for the installation of sprinkles under test, the height of the top of the sprinkler riser has been modified;
 - for the pressure measurement, the test method for pop-up sprinklers has been modified;
- the radius of throw and water distribution curve tests have been added.

A list of all parts in the ISO 15886 series can be found on the ISO website.

Any feedback or questions on this document should be directed to the user's national standards body. A complete listing of these bodies can be found at www.iso.org/members.html.

Agricultural irrigation equipment — Sprinklers —

Part 3: Characterization of distribution and test methods

1 Scope

This document specifies the conditions and methods used for testing and characterizing the water distribution patterns of irrigation sprinklers.

The term sprinkler is used in this document in a broad generic sense and is meant to cover a wide variety of products. The specific performance measurements addressed include distribution uniformity, wetted radius, and water jet trajectory height. This document applies to all irrigation sprinkler classifications for which those three performance measurements are required to verify the design objectives as defined by the manufacturer.

This document deals both with indoor and outdoor tests and with radial and full grid tests. It is organized so as to deal with conditions common to all tests first and then with conditions unique to indoor testing only and finally with conditions unique to outdoor testing only.

For any given sprinkler, a wide range of nozzle configurations, operating conditions, and adjustments generate at least a theoretical need for a correspondingly large number of tests. Testing agencies and manufacturers can use interpolation techniques to reduce the number of actual test runs provided accuracy standards are still being met.

This document does not address the specific performance testing required for sprinklers intended for use in frost protection.

This document does not address the topic of drop spectrum measurement and characterization and the related questions of soil compaction, spray drift, evaporative losses, etc., all of which can be considerations in the design of sprinkler irrigation systems.

This document is used for evaluating irrigation coverage of sprinklers that are identical and arranged in a fixed repeating geometric pattern. This document does not apply to moving systems.

This document applies to part-circle sprinklers provided that the testing agency can satisfy questions of potential anomalies in performance parameters.

NOTE [Annex A](#) addresses the procedures for the characterization of sprinkler pattern uniformity. [Annex B](#) addresses testing part-circle sprinklers.

2 Normative references

There are no normative references in this document.

3 Terms and definitions

For the purposes of this document, the following terms and definitions apply.

ISO and IEC maintain terminological databases for use in standardization at the following addresses:

— ISO Online browsing platform: available at <https://www.iso.org/obp>

— IEC Electropedia: available at <http://www.electropedia.org/>

**3.1
ambient temperature**

temperature of the air surrounding a sprinkler

**3.2
area of coverage**

area within the wetted boundary from the sprinkler operated within the range of *effective application rates* (3.9) specified in the manufacturer's literature

**3.3
Christiansen's uniformity coefficient
UCC**

coefficient using deviations from the mean to characterize the uniformity of field-measured or simulated water application from a grid of sprinklers

**3.4
clean water**

water processed, if necessary, so as to contain suspended particles no larger than 74 µm (200-mesh equivalent) and to contain no dissolved chemicals known to have short-term effects on sprinklers materials

**3.5
collector**

receptacle into which water is deposited during a water distribution test

**3.6
critical dry area**

experience-based definition of the dry area size that defines uniformity of coverage objectives

iTeh STANDARD PREVIEW
(standards.iteh.ai)

**3.7
densogram**

areal map utilizing the density of dots representing water application depth at locations in the *area of coverage* (3.2) of a sprinkler or a grid of sprinklers

ISO 15886-3:2021

<https://standards.iteh.ai/catalog/standards/sist/59d51e5b-c11f-45d1-9695-be4d8108bca8/iso-15886-3-2021>

**3.8
distribution uniformity
DU**

coefficient using the lowest 25 % of water application depths to characterize the uniformity of field-measured or simulated water application from a grid of sprinklers

**3.9
effective application rate**

application rate equal to or exceeding 0,26 mm/h for sprinklers with *flow rates* (3.11) exceeding 120 l/h and 0,13 mm/h for sprinklers with flow rates equal to or less than 120 l/h

**3.10
effective radius of throw**

radius at which 95 % of the reconstituted volume of water discharged by a sprinkler, interpolated between points of measurement, is applied

**3.11
flow rate**

volume of water flowing through a device per unit time

**3.12
full grid collector array**

collectors (3.5) located at the intersections of a two-dimensional geometric grid pattern sufficient in number to give a desired statistical basis for determining water *distribution uniformity* (3.8)

3.13**inlet connection size**

numerical designation used to characterize the sprinkler which is identical to the size of the connection to the irrigation pipe

3.14**irrigation lateral**

branch supply line in an irrigation system on which distribution devices are mounted directly or by means of fittings, risers, or tubes

3.15**nozzle**

aperture of a sprinkler through which water is discharged

3.16**part-circle sprinkler**

sprinkler with an adjustable feature that enables it to irrigate a sector of a circular area either with or without an attachment which enables it to be adjusted to irrigate another sector or the entire circular area

3.17**pop-up sprinkler**

sprinkler designed for installation so that the sprinkler nozzle automatically raises from below ground when the system is pressurized and automatically lowers to its original position when the system is depressurized

3.18**pressure tap**

precisely fabricated connection for communicating internal conduit pressure to an external pressure-measuring device

3.19**radial collector arrays method**

collectors (3.5) located only on a radial axis projected from the centreline of a sprinkler sufficient in number to characterize the water distribution curve

3.20**radius of throw****wetted radius**

distance measured from a centreline of a continuously operating sprinkler to the most remote point at which the sprinkler deposits water at the minimum *effective application rate* (3.9), measured at any arc of coverage except near the arc extremes for part-circle sprinklers

3.21**range of working pressure**

pressures between the minimum working pressure and the maximum working pressure

3.22**rotating sprinkler**

distribution device which, as a result of rotating motion around its axis, distributes water over a circular area, part of a circular area, or a non-circular area

3.23**scheduling coefficient****SC**

coefficient used to characterize the water application uniformity of sprinklers employing an analysis of full-grid test data based on a definition of *critical dry area* (3.6)

3.24**sprinkler spacing**

conventional designation including the distance between the sprinklers along an *irrigation lateral* (3.14) and the distance between consecutive irrigation laterals

3.25

statistical uniformity coefficient

UCS

coefficient using standard deviation as a measure of dispersion in statistical theory to characterize the uniformity of field-measured water application from a full grid of sprinklers

3.26

test pressure

pressure at the inlet of a sprinkler declared by the manufacturer as the pressure to be used for test purposes

3.27

maximum trajectory height

maximum height above a sprinkler of the trajectory of the water stream discharged from the sprinkler nozzle operating under the nominal *test pressure* (3.27)

3.28

water application rate

mean depth of water applied per unit time

3.29

distribution curve

graphical plot of water application depth as a function of distance from a sprinkler along a specified radius

3.30

wind speed

speed of the wind at a test site averaged over the time required for a sprinkler *distribution uniformity* (3.8) test

3.31

working pressure

water pressure recommended by the manufacturer to ensure proper operation of a sprinkler

iTeh STANDARD PREVIEW
(standards.iteh.ai)

ISO 15886-3:2021

<https://standards.iteh.ai/catalog/standards/sist/59d51e5b-c1df-45d1-9685-be4d8d08bca8/iso-15886-3-2021>

4 Collectors

4.1 Collector design

All collectors used for any one test shall be identical. They shall be designed to minimize water splashes in or out and distortions of the catchment volume as may be caused by wind currents.

The height of a collector shall be at least twice the maximum depth of the water collected during the test, but not less than 150 mm.

The collectors shall have a circular opening with sharp edges free from deformities. The diameter shall be between 1/2 to 1 times the height, but not less than 85 mm.

Alternative collector designs may be used, provided that their measuring accuracy is not less than of those described above.

The catchment from a collector shall be quantified from a direct reading of mass, depth, or a volumetric determination provided that the required accuracy standard is met.

4.2 Collector orientation

The openings of all collectors shall be in a common horizontal plane with a slope not exceeding 2 % in any direction. The difference in height between any two adjacent collectors shall not exceed 20 mm.

For indoor testing, collector height is not critical. For outdoor testing, the collector height shall be sufficient to ensure that vegetation does not interfere with jet access to the collectors.

5 Installation of sprinklers under test

The sprinkler selected for testing shall be representative of general production capabilities particularly as relates to the speed of rotation. New sprinklers shall be operated before the test for a period sufficient to demonstrate that the time per revolution has stabilized to $\pm 5\%$.

Mount the sprinkler on a riser with the same nominal size designation as the sprinkler inlet connection size. Ensure that the riser is fixed rigidly vertically, and that it does not vibrate sufficiently to cause a visual effect on the sprinkler operation, bend or deviate from the vertical during the test. The maximum allowable deviation from the vertical during the test shall not exceed 2° .

A steel pipe riser is recommended to provide the required mechanical strength and facilitate the installation of a standard pressure tap.

The sprinkler nozzle height above the collectors should simulate the conditions under which the sprinkler is normally used. For example, with the turf sprinklers the top of the sprinkler body should coincide with the top of the collectors.

For agricultural sprinklers used under a variety of field conditions, the following height requirement applies:

- The height of the top of the sprinkler riser above the openings of the collectors shall be according to the manufacturer's specifications.
- If the manufacturer does not provide specification, the relevant data shall be selected from [Table 1](#), with a tolerance of $\pm 0,05$ m.

Table 1 – Sprinkler height
(standard.itech.ai)

Sprinkler flow rate (l/h)	Top of the sprinkler riser height above the collector (m)
Pop-up	0 (in a non-pressurized state)
0 to 300	0,3
301 to 1 500	0,5
1501 to 2 500	1,0
>2 500	1,5

If the manufacturer specifies any special test-related conditions, for example, testing with straightening vanes, they shall be used if such items are provided as standard equipment with the sprinkler.

For a sprinkler that is not riser-mounted as described in above, the test mounting shall be as specified by the manufacturer.

For single leg distribution patterns, a shelter may be used around the sprinkler to contain jet action provided the following conditions are met:

- The shelter is large enough and so constructed as to trap the water jets and not let them interfere with the sprinkler's operation or contribute to the collector catchment.
- The shelter is designed to allow air circulation to develop around the jets.
- The shelter provides a minimum sector for unrestricted jet operation of 45° centred on the collector radius. If the testing agency uses an angle less than 45° , it shall demonstrate that the integrity of the results is not compromised. Special attention shall be put to sector size, to avoid interception of projections (spoon spit) generated by the impact arm.
- The shelter is designed so that no jet deflection or splash is directed into the collectors.

6 Measurements

6.1 Accuracy of measurements

The accuracy required for all measurements not specifically addressed in this document is $\pm 3\%$.

Water depths within collectors shall be measured with an accuracy of $\pm 3\%$.

Pressure shall be measured with an accuracy of $\pm 1\%$.

Flow rate through the sprinkler shall be measured with an accuracy of $\pm 2\%$.

Time shall be measured with stop watches accurate to $\pm 0,1$ s.

Temperature shall be measured with an accuracy of $\pm 0,5$ °C.

6.2 Pressure measurement

The test pressure shall be measured at the height of the main nozzle. The pressure tap construction details are shown in [Figure 1](#). There shall be no flow obstructions between the pressure tap and the sprinkler base. The bore of the pipe containing the pressure tap shall be clean and smooth. The pressure tap shall be located at the medium point of the riser pipe.

For pop-up sprinklers the pressure shall be measured in the main pipe at a distance of 3D (main pipe) to the sprinkler base.

iTeh STANDARD PREVIEW
(standards.iteh.ai)

[ISO 15886-3:2021](#)

<https://standards.iteh.ai/catalog/standards/sist/59d51e5b-c1df-45d1-9695-be4d8d08bca8/iso-15886-3-2021>

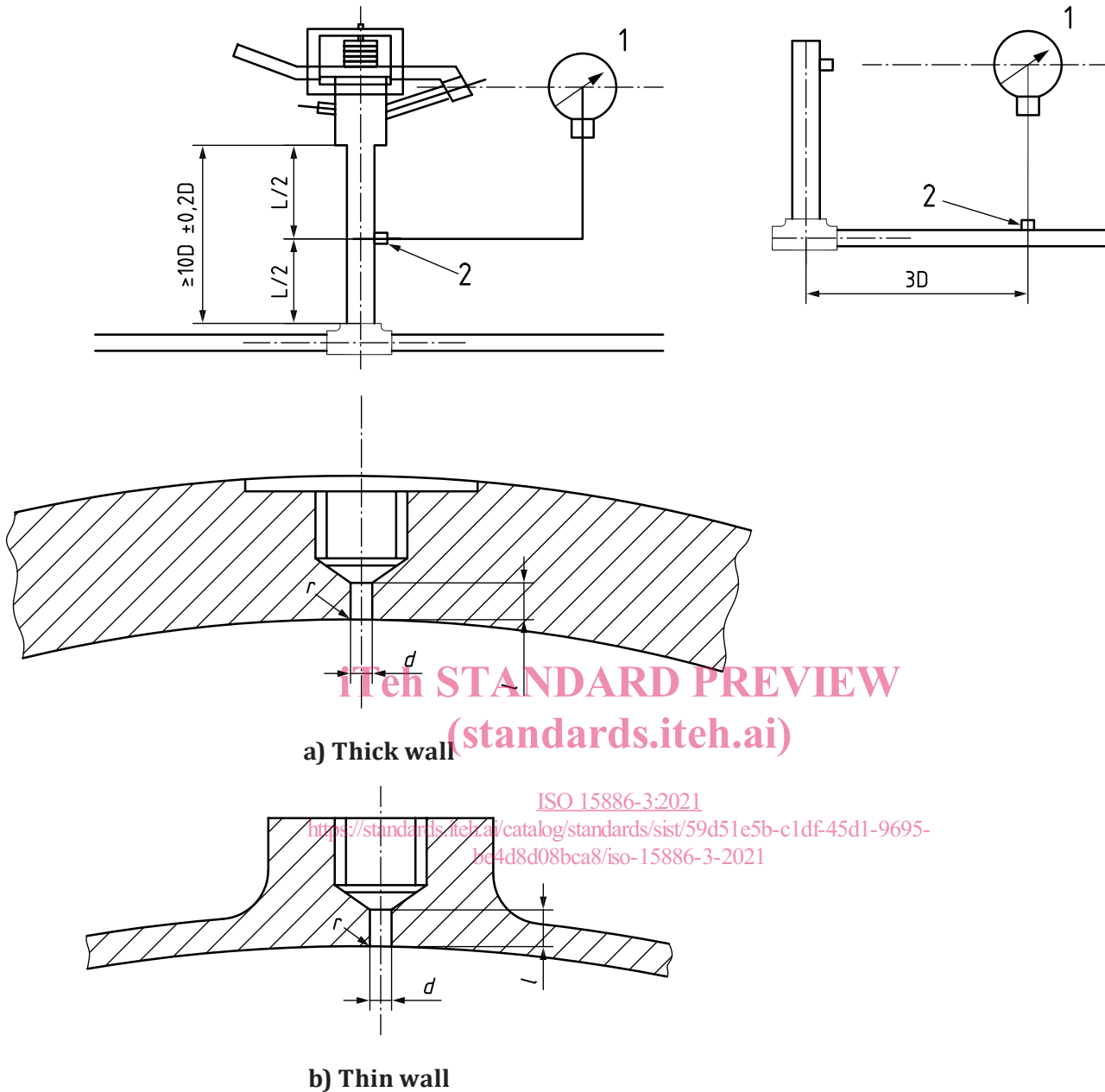

ITeh STANDARD PREVIEW
(standards.iteh.ai)

ISO 15886-3:2021

<https://standards.iteh.ai/catalog/standards/sist/59d51e5b-c1df-45d1-9695-bc4d8d08bca8/iso-15886-3-2021>

Key

- 1 pressure gauge
- 2 pressure tap
- D riser pipe nominal diameter/ main pipe nominal diameter for pop-up sprinklers
- L riser pipe length

Figure 1 — Pressure tap location and construction details

[Figure 1 a\)](#), $l \geq 2,5d$, where $d = 3 \text{ mm to } 6 \text{ mm}$ or $1/10$ pipe diameter, whichever value is smaller.

[Figure 1 b\)](#), $l \geq 2d$; $r \leq d/10$.