



Designation: C1464 – 06(Reapproved 2011)

Standard Specification for Bent Glass¹

This standard is issued under the fixed designation C1464; the number immediately following the designation indicates the year of original adoption or, in the case of revision, the year of last revision. A number in parentheses indicates the year of last reapproval. A superscript epsilon (ϵ) indicates an editorial change since the last revision or reapproval.

1. Scope

1.1 This specification covers the requirements for bent glass used in general building construction, furniture, display, and various other non-automotive applications.

1.2 The dimensional values, stated in SI units are to be regarded as the standard. The values given in parentheses are provided for information only.

1.3 The following safety hazards caveat pertains only to the test method portion, Section 7, of this specification. *This standard does not purport to address all of the safety concerns, if any, associated with its use. It is the responsibility of the user of this standard to establish appropriate safety and health practices and determine the applicability of regulatory limitations prior to use.*

2. Referenced Documents²

2.1 *ASTM Standards:*³

C162 Terminology of Glass and Glass Products

C1036 Specification for Flat Glass

C1048 Specification for Heat-Strengthened and Fully Tempered Flat Glass

C1172 Specification for Laminated Architectural Flat Glass

C1422 Specification for Chemically Strengthened Flat Glass

2.2 *Federal Document:*⁴

CPSC 16 CFR 1201 Consumer Product Safety Commission Safety Standard for Architectural Glazing Material

3. Terminology

3.1 *Definitions:*

¹ This specification is under the jurisdiction of ASTM Committee C14 on Glass and Glass Products and is the direct responsibility of Subcommittee C14.08 on Flat Glass.

Current edition approved Oct. 1, 2011. Published October 2011. Originally approved in 2000. Last previous edition approved in 2006 as C1464-06. DOI: 10.1520/C1464-06R11.

² Reference to these standards shall be the latest revision unless otherwise specified by the authority applying this specification.

³ For referenced ASTM standards, visit the ASTM website, www.astm.org, or contact ASTM Customer Service at service@astm.org. For *Annual Book of ASTM Standards* volume information, refer to the standard's Document Summary page on the ASTM website.

⁴ Available from the Superintendent of Documents, U.S. Government Printing Office, Washington, DC 20402.

3.1.1 Refer to Terminology C162, Specifications C1036, C1422, and C1172, as appropriate.

3.1.2 *Blemishes in Flat Glass*—Refer to Specifications C1036, C1048, C1422, and C1172, as appropriate.

3.2 *Definitions of Terms Specific to This Standard:*

3.2.1 *bent glass, n*—flat glass that has been shaped while hot into a body having curved surfaces.

3.2.2 *chord, n*—a straight line segment that joins two points of an arc.

3.2.3 *compound bend, n*—a profile shape composed of curvature of one or more radii, curved on two or more axes.

3.2.4 *crossbend, n*—deviation from a straight edge along a line perpendicular to the curvature measured on the concave side.

3.2.5 *cylindrical bend, n*—a profile shape composed of a single curvature with a constant radius and no straight sections, all curved on a single axis.

3.2.6 *degree of angle, n*—the angular measurement of a segment of a curve.

3.2.7 *depth, n*—on a circular bend, the distance from the midpoint of a chord to the arc measured along its radius perpendicular to the circumference.

3.2.8 *elliptical bend, n*—a curved profile shape composed of two or more tangential radii on a single axis.

3.2.9 *girth, n*—the distance around the concave or convex surface measured perpendicular to the height including any flats.

3.2.10 *height, n*—the length measurement of the edge perpendicular to the horizontal arc or girth.

3.2.11 *multiple bend, n*—a profile shape composed of a curvature of two or more radii, all curved on a single axis, with at least two of the curvatures possibly separated by a flat (plane) area, and with or without one or more additional flat (plane) areas tangent to the curvatures.

3.2.12 *pock marks, n*—process surface blemishes that consist of small, shallow areas, circular in shape, on the surface of the glass.

3.2.13 *Ring marks*—process surface blemishes that consist of shallow marks typically running along the perimeter of the glass surface.

3.2.14 *Rotation*—a condition where vertical edges (perpendicular to arc) are not parallel to bending axis.

3.2.15 *Serpentine bend*—profile shape composed of concave and convex curvatures of one or more radii on a single axis with or without flat areas tangent to the curvatures.

3.2.16 *Shape*—contoured form including curvature, arc(s), and even flats.

3.2.17 *Single bend*—a profile composed of a single radius curved on a single axis, possibly with one or two flat (plane) areas tangent to the curvature.

3.2.18 *Twist*—one or more of the corners of the glass are not in the same plane.

4. Classification

4.1 *Kinds*—Bent glass furnished under this specification shall be of the following kinds, as specified:

4.1.1 *Kind BA*—Bent glass shall be annealed flat glass, either transparent, patterned, or wired glass in accordance with the applicable requirements of Specification C1036, as further processed to conform with the requirements hereinafter specified for bent glass.

4.1.2 *Kind BCS*—Chemically strengthened bent glass shall be flat glass, either transparent or patterned, in accordance with the applicable requirements of Specification C1036, as further processed to conform with the requirements hereinafter specified for bent glass and in accordance with the applicable requirements of Specification C1422 for chemically strengthened flat glass.

4.1.3 *Kind BFT*—Fully tempered bent glass shall be flat glass, either transparent or patterned, in accordance with the applicable requirements of Specification C1036, as further processed to conform with the requirements hereinafter speci-

fied for bent glass and in accordance with the applicable requirements of Specification C1048 for fully tempered glass.

4.1.4 *Kind BHS*—Heat-strengthened bent glass shall be flat glass, either transparent or patterned, in accordance with the applicable requirements of Specification C1036, as further processed to conform with the requirements hereinafter specified for bent glass and in accordance with the applicable requirements of Specification C1048 for heat-strengthened glass.

4.1.5 *Kind BL*—Laminated bent glass shall be flat glass, either transparent or patterned, in accordance with the applicable requirements of Specification C1036 as further processed with the requirements hereinafter specified for bent glass and in accordance with the applicable requirements of Specification C1172 for laminated glass.

4.1.6 *Kind BX*—Bent glass with miscellaneous combinations not previously combined.

5. Ordering Information

5.1 Purchasers should include the following information in procurement documents:

- 5.1.1 Title, number, and date of this specification.
- 5.1.2 Kind of bent glass as referred to in this specification (see Section 4).
- 5.1.3 Fabrication requirements (see Section 6).
- 5.1.4 *Thickness Requirements:*
 - 5.1.4.1 Overall thickness designation.
 - 5.1.4.2 Thickness of individual lites in the laminate.
 - 5.1.4.3 Interlayer thickness and type.
- 5.1.5 Nominal height, width, radius (see definitions and Figs. 1-3).

<https://standards.iteh.ai/catalog/standards/sist/b1603464-292d-47e0-ab20-722a992227b4/astm-c1464-062011>

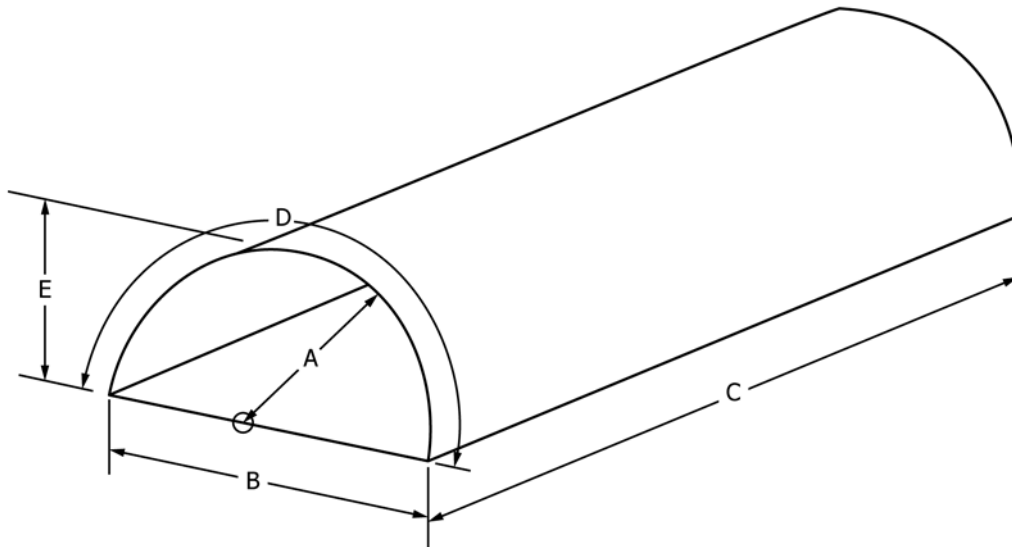

- A = outside radius
- B = chord
- C = height
- D = girth
- E = depth

FIG. 1 Cylindrical Bend