



Designation: D3235 – 06(Reapproved 2011)

Standard Test Method for Solvent Extractables in Petroleum Waxes¹

This standard is issued under the fixed designation D3235; the number immediately following the designation indicates the year of original adoption or, in the case of revision, the year of last revision. A number in parentheses indicates the year of last reapproval. A superscript epsilon (ϵ) indicates an editorial change since the last revision or reapproval.

1. Scope

1.1 This test method covers the determination of solvent extractables in petroleum waxes.

1.2 The values stated in SI units are to be regarded as standard. The values given in parentheses are for information only.

1.3 *This standard does not purport to address all of the safety concerns, if any, associated with its use. It is the responsibility of the user of this standard to establish appropriate safety and health practices and determine the applicability of regulatory limitations prior to use.*

2. Referenced Documents

2.1 *ASTM Standards:*²

E1 Specification for ASTM Liquid-in-Glass Thermometers

E128 Test Method for Maximum Pore Diameter and Permeability of Rigid Porous Filters for Laboratory Use

3. Summary of Test Method

3.1 The sample is dissolved in a mixture consisting of 50 volume % methyl ethyl ketone and 50 volume % toluene. The solution is cooled to -32°C (-25°F) to precipitate the wax, then filtered. The solvent extractables content is determined by evaporating the solvent from the filtrate and weighing the residue.

4. Significance and Use

4.1 The solvent extractables in a wax may have significant effects on several of its properties such as strength, hardness, flexibility, scuff resistance, coefficient of friction, coefficient of expansion, melting point, and staining characteristics. Whether these effects are desirable or undesirable depends on the intended use of the wax.

5. Apparatus

5.1 *Filter Stick and Assembly*, consisting of a 10-mm diameter sintered glass filter stick of 10 to 15 μm maximum pore diameter as determined by the method in [Appendix X1](#), provided with an air pressure inlet tube and delivery nozzle. It is provided with a ground-glass joint to fit a 25 by 170-mm test tube. The dimensions for a suitable filtration assembly are shown in [Fig. 1](#).

NOTE 1—A metallic filter stick may be employed if desired. A filter stick³ made of stainless steel and having a 12.7-mm (0.50-in.) disk of 10 to 15 μm maximum pore diameter, as determined by Test Method [E128](#), has been found to be satisfactory. The metallic apparatus is inserted into a 25 by 150-mm test tube and held in place by means of a cork.

5.2 *Cooling Bath*, consisting of an insulated box with $30 \pm 5\text{-mm}$ ($1.2 \pm 0.2\text{-in.}$) holes in the center to accommodate any desired number of test tubes. The bath may be filled with a suitable medium such as kerosine, and may be cooled by circulating a refrigerant through coils, or by using solid carbon dioxide. A suitable cooling bath to accommodate three test tubes is shown in [Fig. 2](#).

5.3 *Dropper Pipet*, dispensing device capable of delivering 0.5 ± 0.05 g of molten wax.

5.4 *Transfer Pipet*, or equivalent volume dispensing device, capable of delivering 15 ± 0.06 mL.

5.5 *Air Pressure Regulator*, designed to supply air to the filtration assembly ([8.5](#)) at sufficient pressure to give an even flow of filtrate. Either a conventional pressure-reducing valve or a mercury bubbler-type regulator has been found satisfactory. The latter type, illustrated in [Fig. 3](#), consists of a 250-mL glass cylinder and a T-tube held in the cylinder by means of a rubber stopper grooved at the sides to permit the escape of excess air. The volume and pressure of the air supplied to the filtration assembly is regulated by the depth to which the T-tube is immersed in mercury at the bottom of the cylinder. Absorbent cotton placed in the space above the mercury prevents the

¹ This test method is under the jurisdiction of ASTM Committee D02 on Petroleum Products, Liquid Fuels, and Lubricants and is the direct responsibility of Subcommittee D02.10.0A on Physical/Chemical Properties.

Current edition approved Oct. 1, 2011. Published October 2011. Originally approved in 1973. Last previous edition approved in 2006 as D3235 - 06. DOI: 10.1520/D3235-06R11.

² For referenced ASTM standards, visit the ASTM website, www.astm.org, or contact ASTM Customer Service at service@astm.org. For *Annual Book of ASTM Standards* volume information, refer to the standard's Document Summary page on the ASTM website.

³ The sole source of supply of a suitable metal filter stick with designated porosity G known to the committee at this time is the Pall Trinity Micro Corp., Route 281, Cortland, NY 13045. A list of United Kingdom suppliers can be obtained from Energy Institute, 61 New Cavendish St., London, W1G 7AR, United Kingdom. If you are aware of alternative suppliers, please provide this information to ASTM International Headquarters. Your comments will receive careful consideration at a meeting of the responsible technical committee,¹ which you may attend.

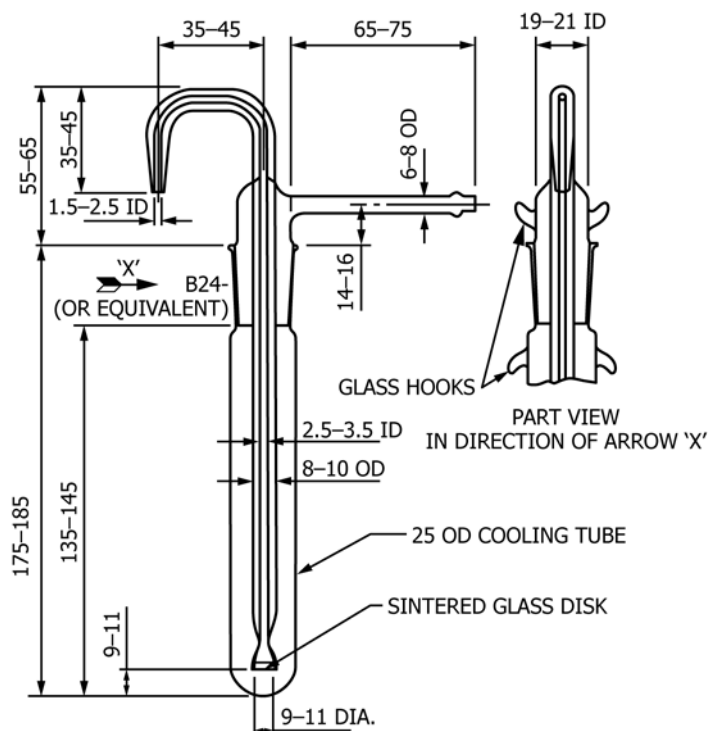

All dimensions are in millimetres.

FIG. 1 Filter Stick

loss of mercury by spattering. The air pressure regulator is connected to the filter stick and assembly by means of rubber tubing.

5.6 Temperature Measuring Devices:

5.6.1 *Thermometers*, two, having a range as shown below and conforming to the requirements as prescribed in Specification E1 or in the specifications for IP Standard Thermometers. One thermometer is required for the cold bath and a second thermometer is required for the sample solution.

Temperature Range	Thermometer Number	
	ASTM	IP
-37 to +21°C	71C	72C
-35 to +70°F	71F	72F

5.6.2 Temperature measuring devices other than those described in 5.6.1 are satisfactory for this test method, provided they exhibit the same temperature response as the equivalent mercury-in-glass thermometers.

5.7 *Weighing Bottles*, glass-stoppered, having a typical capacity of 15-25 mL.

5.8 *Evaporation Assembly*, consisting of an evaporating cabinet and connections, essentially as illustrated in Fig. 4, and capable of maintaining a temperature of $35 \pm 1^\circ\text{C}$ ($95 \pm 2^\circ\text{F}$) around the evaporation flasks. Construct the jets with an inside diameter of 4 ± 0.2 mm for delivering a stream of clean, dry air vertically downward into the weighing bottle. Support each jet so that the tip is 15 ± 5 mm above the surface of the liquid at the start of the evaporation. Supply purified air at the rate of 2 to 3 L/min per jet. One way to purify the air is to pass it through a tube of approximately 1-cm bore packed loosely to a height of approximately 20 cm with absorbent cotton.

Periodically check the cleanliness of the air by evaporating 4 mL of the solvent mixture described in 6.3 by the procedure specified in 8.5. When the residue does not exceed 0.1 mg, the evaporation equipment is operating satisfactorily.

NOTE 2—Investigations by the European World Federation have indicated that improved precision may be achieved by individually calibrating each nozzle to deliver a flow rate of 2 to 3 L/min.

5.9 *Analytical Balance*, capable of reproducing weights to 0.1 mg.

5.10 *Wire Stirrer*—A piece of stiff made of iron, stainless steel, or Nichrome wire of about No. 20 Bands (0.9 mm in diameter) or 16 swg. gage, 250 mm long. A 10-mm diameter loop is formed at each end, and the loop at the bottom end is bent so that the plane of the loop is perpendicular to the wire.

6. Solvent

6.1 *Methyl Ethyl Ketone*, conforming to the specifications of the Committee on Analytical Reagents of the American Chemical Society.⁴

6.2 *Toluene*, conforming to the specifications of the Committee on Analytical Reagents of the American Chemical Society.⁴

⁴ *Reagent Chemicals, American Chemical Society Specifications*, American Chemical Society, Washington, DC. For Suggestions on the testing of reagents not listed by the American Chemical Society, see *Annual Standards for Laboratory Chemicals*, BDH Ltd., Poole, Dorset, U.K., and the *United States Pharmacopeia and National Formulary*, U.S. Pharmacopeial Convention, Inc. (USPC), Rockville, MD.

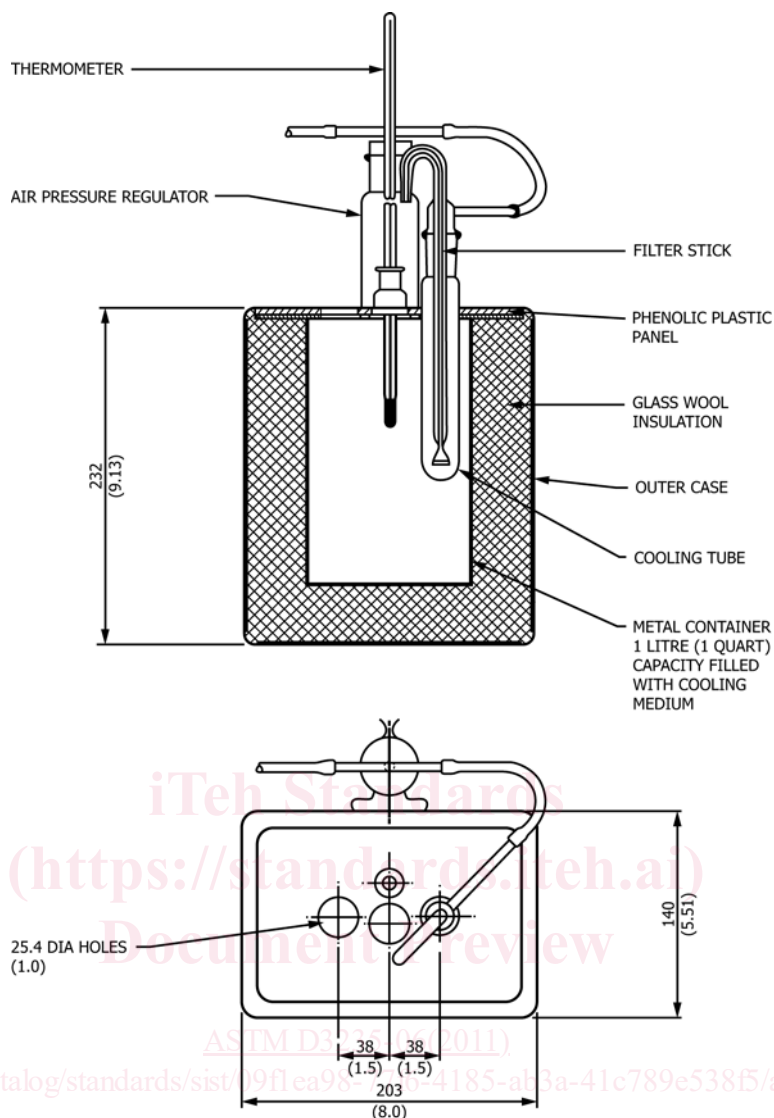

All dimensions are in millimetres (inches).

FIG. 2 Cooling Bath

6.3 *Solvent Mixture*—Prepare a mixture of 50 volume % methyl ethyl ketone and 50 volume % toluene.

6.4 Store the solvent mixture over anhydrous calcium sulfate (5 weight % of the solvent). Filter prior to use.

7. Sample

7.1 Obtain a representative portion by melting the entire sample and stirring thoroughly. This is necessary because the extractables may not be distributed uniformly throughout the solidified sample.

8. Procedure

8.1 Melt a representative portion of the sample, using a water bath or oven maintained at 70 to 100°C (158 to 212°F). As soon as the wax is completely melted, thoroughly mix. Preheat the pipet or equivalent measuring device in order to prevent the solidification of wax in the tip, and withdraw a portion of the sample as soon as possible after the wax has

melted. The mass of wax transferred to the test tube must be 1.00 ± 0.05 g. Allow the test tube to cool, and weigh to at least the nearest 1 mg.

NOTE 3—The weight of a test tube which is cleaned by means of solvent will not vary to a significant extent. Therefore, a tare weight may be obtained and used repeatedly.

8.2 Pipet 15 mL of the solvent mixture into the test tube and place the latter just up to the level of its contents in a hot water or steam bath. Heat the solvent-wax mixture, stirring up and down with the wire stirrer, until a homogeneous solution is obtained. Exercise care to avoid loss of solvent by prolonged boiling.

NOTE 4—Very high-melting wax samples may not form clear solutions. Stir until the undissolved material is well dispersed as a fine cloud.

8.2.1 Plunge the test tube into an 800-mL beaker of ice water and continue to stir until the contents are cold. Remove the stirrer. Remove the test tube from the ice bath, wipe dry on the outside with a cloth, and weigh to at least the nearest 0.1 g.