

---

---

**Hand-held portable power tools —  
Test methods for evaluation of  
vibration emission —**

**Part 1:  
Angle and vertical grinders**

**iTeh STANDARD PREVIEW**  
**(standards.iteh.ai)**  
*Machines à moteur portatives — Méthodes d'essai pour l'évaluation  
de l'émission de vibrations —  
Partie 1: Meuleuses verticales et meuleuses d'angles*

[ISO 28927-1:2019](https://standards.iteh.ai/catalog/standards/sist/9801bf2-8492-4786-bae3-1f42f4143480/iso-28927-1-2019)

<https://standards.iteh.ai/catalog/standards/sist/9801bf2-8492-4786-bae3-1f42f4143480/iso-28927-1-2019>



**iTeh STANDARD PREVIEW**  
**(standards.iteh.ai)**

ISO 28927-1:2019

<https://standards.iteh.ai/catalog/standards/sist/9801bf2-8492-4786-bae3-1f42f4143480/iso-28927-1-2019>



**COPYRIGHT PROTECTED DOCUMENT**

© ISO 2019

All rights reserved. Unless otherwise specified, or required in the context of its implementation, no part of this publication may be reproduced or utilized otherwise in any form or by any means, electronic or mechanical, including photocopying, or posting on the internet or an intranet, without prior written permission. Permission can be requested from either ISO at the address below or ISO's member body in the country of the requester.

ISO copyright office  
CP 401 • Ch. de Blandonnet 8  
CH-1214 Vernier, Geneva  
Phone: +41 22 749 01 11  
Fax: +41 22 749 09 47  
Email: [copyright@iso.org](mailto:copyright@iso.org)  
Website: [www.iso.org](http://www.iso.org)

Published in Switzerland

# Contents

	Page
<b>Foreword</b> .....	<b>iv</b>
<b>Introduction</b> .....	<b>v</b>
<b>1 Scope</b> .....	<b>1</b>
<b>2 Normative references</b> .....	<b>1</b>
<b>3 Terms and definitions</b> .....	<b>1</b>
3.1 Terms and definitions.....	2
3.2 Symbols.....	2
<b>4 Basic standards and vibration test codes</b> .....	<b>2</b>
<b>5 Description of the family of machines</b> .....	<b>3</b>
<b>6 Characterization of vibration</b> .....	<b>5</b>
6.1 Direction of measurement.....	5
6.2 Location of measurements.....	5
6.3 Magnitude of vibration.....	8
6.4 Combination of vibration directions.....	8
<b>7 Instrumentation requirements</b> .....	<b>8</b>
7.1 General.....	8
7.2 Mounting of transducers.....	8
7.2.1 Specification of transducer.....	8
7.2.2 Fastening of transducers.....	8
7.3 Frequency weighting filter.....	9
7.4 Integration time.....	9
7.5 Auxiliary equipment.....	9
7.6 Calibration.....	9
<b>8 Testing and operating conditions of the machinery</b> .....	<b>9</b>
8.1 General.....	9
8.2 Operating conditions.....	10
8.2.1 Pneumatic machines.....	10
8.2.2 Hydraulic machines.....	10
8.2.3 Electrical machines.....	10
8.3 Other quantities to be specified.....	10
8.4 Attached equipment, work piece and task.....	10
8.4.1 Test wheel.....	10
8.4.2 Feed force.....	11
8.4.3 Test procedure.....	13
8.5 Operators.....	13
<b>9 Measurement procedure and validity</b> .....	<b>13</b>
9.1 Reported vibration values.....	13
9.2 Declaration and verification of the vibration emission value.....	14
9.3 Correction factor.....	14
<b>10 Measurement report</b> .....	<b>15</b>
<b>Annex A (informative) Model test report for vibration emission of angle and vertical grinders</b> .....	<b>16</b>
<b>Annex B (normative) Determination of uncertainty</b> .....	<b>18</b>
<b>Annex C (normative) Design of test wheel</b> .....	<b>20</b>
<b>Bibliography</b> .....	<b>28</b>

## Foreword

ISO (the International Organization for Standardization) is a worldwide federation of national standards bodies (ISO member bodies). The work of preparing International Standards is normally carried out through ISO technical committees. Each member body interested in a subject for which a technical committee has been established has the right to be represented on that committee. International organizations, governmental and non-governmental, in liaison with ISO, also take part in the work. ISO collaborates closely with the International Electrotechnical Commission (IEC) on all matters of electrotechnical standardization.

The procedures used to develop this document and those intended for its further maintenance are described in the ISO/IEC Directives, Part 1. In particular, the different approval criteria needed for the different types of ISO documents should be noted. This document was drafted in accordance with the editorial rules of the ISO/IEC Directives, Part 2 (see [www.iso.org/directives](http://www.iso.org/directives)).

Attention is drawn to the possibility that some of the elements of this document may be the subject of patent rights. ISO shall not be held responsible for identifying any or all such patent rights. Details of any patent rights identified during the development of the document will be in the Introduction and/or on the ISO list of patent declarations received (see [www.iso.org/patents](http://www.iso.org/patents)).

Any trade name used in this document is information given for the convenience of users and does not constitute an endorsement.

For an explanation of the voluntary nature of standards, the meaning of ISO specific terms and expressions related to conformity assessment, as well as information about ISO's adherence to the World Trade Organization (WTO) principles in the Technical Barriers to Trade (TBT), see [www.iso.org/iso/foreword.html](http://www.iso.org/iso/foreword.html).

This document was prepared by Technical Committee ISO/TC 118, *Compressors and pneumatic tools, machines and equipment*, Subcommittee SC 3, *Pneumatic tools and machines*.

This second edition cancels and replaces the first edition (ISO 28927-1:2009) and (ISO 28927-1:2009/Amd.1:2017), of which it constitutes a minor revision. The changes compared to the previous edition are as follows:

- [Table C.4](#), in "Radius to centre of hole", change  $rh$  to  $r_h$ ;
- [Table C.4](#), in "Radius to centre of threaded hole", change  $rt$  to  $r_t$ ;
- [Figure C.4](#), change  $r_s$  to  $r_i$ ;
- [Figure C.4](#), change  $r_t$  to  $r_h$ ;
- [Figure C.4](#), in the key, change  $r_s$  to  $r_h$ .

A list of all parts in the ISO 28927 series can be found on the ISO website.

Any feedback or questions on this document should be directed to the user's national standards body. A complete listing of these bodies can be found at [www.iso.org/members.html](http://www.iso.org/members.html).

## Introduction

This document is a type-C standard as stated in ISO 12100.

When requirements of this type-C standard are different from those which are stated in type-A or -B standards, the requirements of this type-C standard take precedence over the requirements of the other standards for machines that have been designed and built according to the requirements of this type-C standard.

The vibration test codes for portable hand-held machines given in ISO 28927 are based on ISO 20643, which gives general specifications for the measurement of the vibration emission of hand-held and hand-guided machinery. ISO 28927 specifies the operation of the machines under type-test conditions and other requirements for the performance of type tests. The structure/numbering of its clauses follows that of ISO 20643.

The basic principle for transducer positioning first introduced in the EN 60745 series of European standards is followed, representing a deviation from ISO 20643 for reasons of consistency. The transducers are primarily positioned next to the hand in the area between the thumb and the index finger, where they give the least disturbance to the operator gripping the machine.

It has been found that vibrations generated by grinders vary considerably in typical use. This is largely due to the variances in the unbalance of the machine with the grinding wheel mounted. The unbalance also changes when the wheel is worn through operation.

In order to provide a method that gives good measurement reproducibility, the procedure adopted in this document uses a test wheel of known unbalance mounted on a machine and run under no-load conditions. The unbalance for the different types of test wheel are chosen to give vibration values that are as far as possible in accordance with ISO 20643. The procedures of ISO 5349 are required whenever exposure at the workplace is to be assessed.

Underestimation of the vibration for machines equipped with technical means to automatically reduce unbalances is taken into account by multiplying the vibration values of such machines with a correction factor of 1,3.

For grinders that are intended to be used with cupped wire brushes, the vibration value is obtained by using a correction factor of 1,6.

The values obtained are type-test values intended to be representative of the average of the upper quartile of typical vibration magnitudes in real-world use of the machines. However, the actual magnitudes will vary considerably from time to time and depend on many factors, including the operator, the task and the inserted tool or consumable. The state of maintenance of the machine itself might also be of importance. Under real working conditions the influences of the operator and process can be particularly important at low magnitudes. It is therefore not recommended that emission values below  $2,5 \text{ m/s}^2$  be used for estimating the vibration magnitude under real working conditions. In such cases,  $2,5 \text{ m/s}^2$  is the recommended vibration magnitude for estimating the machine vibration.

If accurate values for a specific work place are required, then measurements (according to ISO 5349) in that work situation could be necessary. Vibration values measured in real working conditions can be either higher or lower than the values obtained using this document.

Higher vibration magnitudes can easily occur in real work situations, caused by the use of excessively unbalanced grinding wheels, worn flanges or bent spindles.

The vibration test codes given in ISO 28927 supersede those given in ISO 8662, whose parts have been replaced by the corresponding parts of ISO 28927 (see Foreword).

NOTE ISO 8662-11, *Hand-held portable power tools — Measurement of vibrations at the handle — Part 11: Fastener driving tools* could be replaced by a future part of ISO 28927.

**iTeh STANDARD PREVIEW**  
**(standards.iteh.ai)**

ISO 28927-1:2019

<https://standards.iteh.ai/catalog/standards/sist/9801bf2-8492-4786-bae3-1f42f4143480/iso-28927-1-2019>

# Hand-held portable power tools — Test methods for evaluation of vibration emission —

## Part 1: Angle and vertical grinders

### 1 Scope

This document specifies a laboratory method for measuring hand-transmitted vibration emission at the handles of hand-held power-driven angle and vertical grinders. It is a type-test procedure for establishing the magnitude of vibration in the gripping areas of a machine fitted with a specified test wheel and run under no-load conditions. The method has been established for surface grinding tasks only. Cutting and sanding generally create lower vibrations. It is intended that the results be used to compare different models of the same type of machine.

This document is applicable to hand-held machines (see [Clause 5](#)), driven pneumatically or by other means, intended for grinding, cutting-off and rough sanding, with bonded, coated and super-abrasive products and with wire brushes for use on all kinds of materials. It is not applicable to die grinders or straight grinders.

NOTE To avoid confusion with the terms “power tool” and “inserted tool”, *machine* is used for the former throughout this document.

### 2 Normative references

ISO 28927-1:2019

The following documents are referred to in the text in such a way that some or all of their content constitutes requirements of this document. For dated references, only the edition cited applies. For undated references, the latest edition of the referenced document (including any amendments) applies.

ISO 2787, *Rotary and percussive pneumatic tools — Performance tests*

ISO 5349 (all parts), *Mechanical vibration — Measurement and evaluation of human exposure to hand-transmitted vibration*

ISO 5391, *Pneumatic tools and machines — Vocabulary*

ISO 17066, *Hydraulic tools — Vocabulary*

ISO 20643:2005, *Mechanical vibration — Hand-held and hand-guided machinery — Principles for evaluation of vibration emission*

EN 755-2, *Aluminium and aluminium alloys — Extruded rod/bar, tube and profiles — Part 2: Mechanical properties*

EN 12096, *Mechanical vibration — Declaration and verification of vibration emission values*

### 3 Terms and definitions

For the purposes of this document, the terms and definitions given in ISO 5391, ISO 17066 and ISO 20643, and the following terms, definitions and symbols, apply.

ISO and IEC maintain terminological databases for use in standardization at the following addresses:

— ISO Online browsing platform: available at <https://www.iso.org/obp>

— IEC Electropedia: available at <http://www.electropedia.org/>

### 3.1 Terms and definitions

#### 3.1.1

##### **grinder**

machine driving a rotary output spindle adapted to carry an abrasive wheel/device for material removal

[SOURCE: ISO 5391:2003, 2.1.3, modified — Definition rephrased and note deleted.]

#### 3.1.2

##### **angle grinder**

grinder where the output spindle is at a given angle (usually a right angle) to the motor axis

[SOURCE: ISO 5391:2003, 2.1.3.3]

#### 3.1.3

##### **vertical grinder**

grinder where the handle or handles are at an angle to the coaxially aligned motor and output spindle axis

[SOURCE: ISO 5391:2003, 2.1.3.2]

#### 3.1.4

##### **test wheel**

aluminium wheel geometrically similar to a real grinding wheel, with holes on specified radii to give defined unbalances

**iTeh STANDARD PREVIEW**  
(standards.iteh.ai)

### 3.2 Symbols

Symbol	Description	Unit
$a_{hw}$	root-mean-square (r.m.s.) single-axis acceleration value of the frequency-weighted hand-transmitted vibration	m/s <sup>2</sup>
$a_{hv}$	vibration total value of frequency-weighted r.m.s. acceleration; root sum of squares of $a_{hw}$ values for the three measured axes of vibration	m/s <sup>2</sup>
$a_{hvmeas}$	$a_{hv}$ as measured during testing	m/s <sup>2</sup>
$a_{hvrat}$	$a_{hv}$ at rated no-load speed	m/s <sup>2</sup>
$\overline{a_{hv}}$	arithmetic mean value of $a_{hv}$ values of runs for one operator for one hand position	m/s <sup>2</sup>
$a_h$	arithmetic mean value of $\overline{a_{hv}}$ values for all operators for one hand position	m/s <sup>2</sup>
$\overline{a_h}$	arithmetic mean value of $a_h$ values for one hand position on several machines	m/s <sup>2</sup>
$a_{hd}$	declared vibration emission value	m/s <sup>2</sup>
$n_{meas}$	measured no-load speed during testing with the test wheel mounted	r/min
$n_{rat}$	rated no-load speed: maximum rotational-speed of the machine according to the speed marking of the machine	r/min
$s_{n-1}$	standard deviation for a test series (for a sample, $s$ )	m/s <sup>2</sup>
$\sigma_R$	standard deviation of reproducibility (for a population, $\sigma$ )	m/s <sup>2</sup>
$C_V$	coefficient of variation for a test series	
$K$	uncertainty	m/s <sup>2</sup>

## 4 Basic standards and vibration test codes

This document is based on the requirements of ISO 20643 and corresponds to its structure in respect of clause subjects and numbering except for the annexes.



[Annex A](#) presents a model test report, [Annex B](#) the means for determining the uncertainty,  $K$ , and [Annex C](#) specifies test wheel design.

## 5 Description of the family of machines

This document applies to hand-held machines fitted with guards, which are intended for grinding, cutting-off and rough sanding, with bonded, coated and super abrasive products for use on all kinds of materials.

For sanders without guards, see ISO 28927-3.

For applicable wheel types, as defined in ISO 603-14 and ISO 603-16, see [Table 1](#).

The family of machines covered by this document comprises the following machines:

- angle and vertical grinders with type 27 wheels of diameters 80 mm to 300 mm; when the same guard is also used for type 41 cutting-off wheels then only the vibration value for the type 27 test wheel need be declared (see [8.4.1](#) for test wheel specifications);
- angle and vertical grinders with special guards for type 41 cut off wheels; the test shall be carried out using a type 27 test wheel (see [8.4.1](#) for test wheel specifications);
- angle and vertical grinders with special guards for stone cutting wheels; the test shall be carried out using the most appropriate wheel from the types described in [Table 2](#);
- angle and vertical grinders for types 6 and 11 cup wheels with diameters 100 mm to 180 mm;
- angle and vertical grinders, as well as sanders for fibre discs and flap wheels with diameters 80 mm to 300 mm.

NOTE For wheels with a diameter less than 80 mm, see ISO 603-14.

[Figures 1](#) to [6](#) show examples of typical grinders covered by this document.

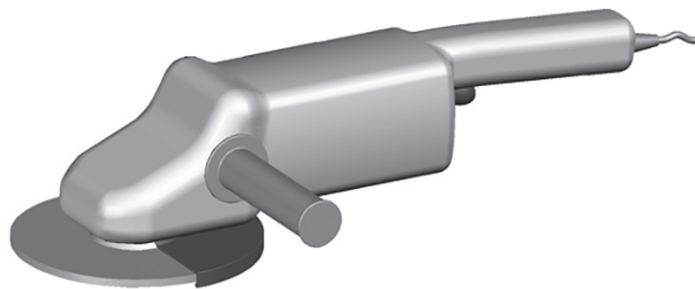

**Figure 1 — Electrical angle grinder with separate main handle**

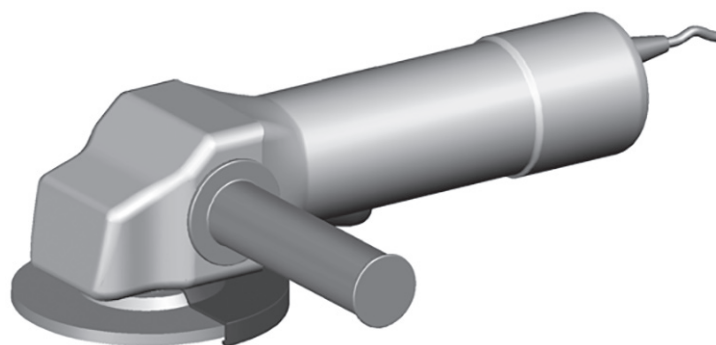

**Figure 2 — Electrical angle grinder whose motor serves as main handle**

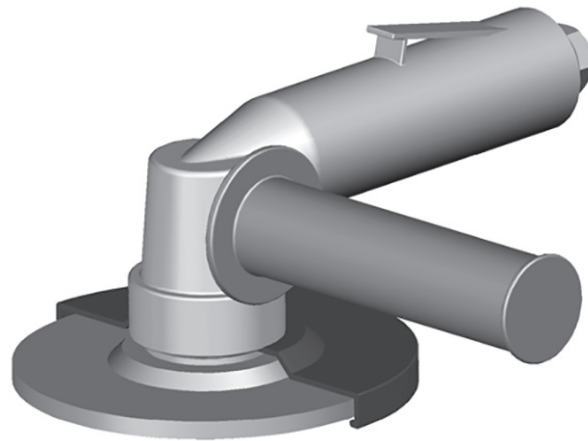

**Figure 3 — Pneumatic angle grinder whose motor serves as main handle**

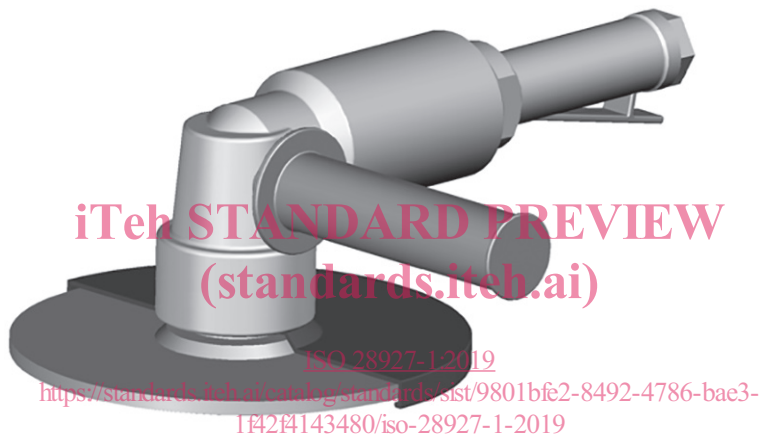

**Figure 4 — Pneumatic angle grinder with separate main handle**

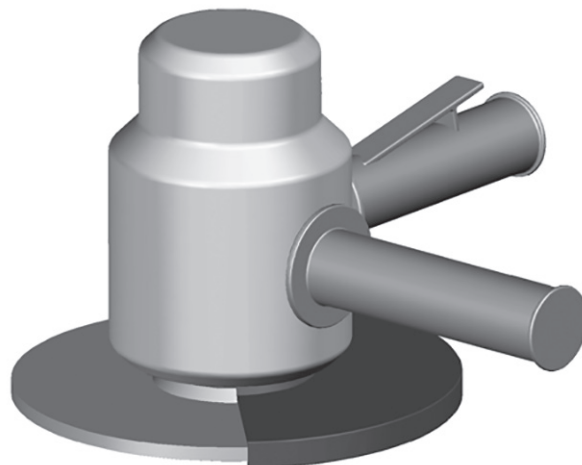

**Figure 5 — Pneumatic vertical grinder**

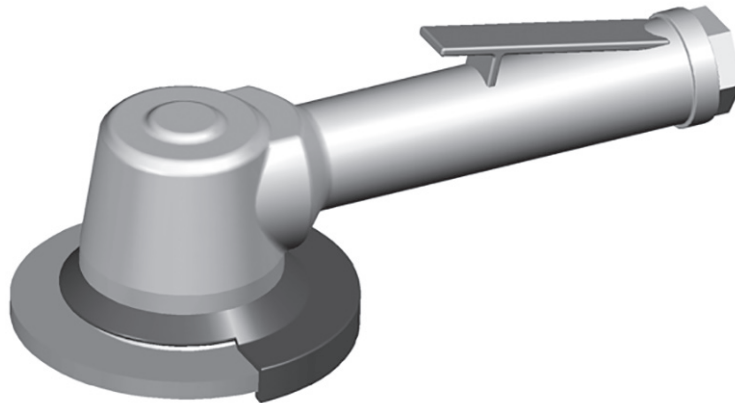

**Figure 6 — Angle grinder intended for one-handed operation**

NOTE This document only covers wheel dimensions included in ISO 603-14. For other wheel dimensions, use ISO 20643.

## 6 Characterization of vibration

### 6.1 Direction of measurement

The vibration transmitted to the hand shall be measured and reported for three directions of an orthogonal coordinate system. At each hand position, the vibration shall be measured simultaneously in the three directions shown in [Figures 7 to 12](#).

### 6.2 Location of measurements

Measurements shall be made at the gripping zones, where the operator normally holds the machine and applies the feed force. For machines intended for one-handed operation, it is only necessary to measure at a single point.

The prescribed transducer location shall be as close as possible to the hand between the thumb and index finger. This shall apply to both hand positions, with the machine held as in normal operation. Whenever possible, measurements shall be made at the prescribed locations.

A secondary location is defined as being on the side of, and as close as possible to, the inner end of the handle where the prescribed location is found. If a prescribed location of the transducer cannot be used, this secondary location shall be used instead.

The prescribed or secondary locations shall also be used on anti-vibration handles.

[Figures 7 to 12](#) show the prescribed and secondary locations and measurement directions for the hand positions normally used for the different types of machines in this family.

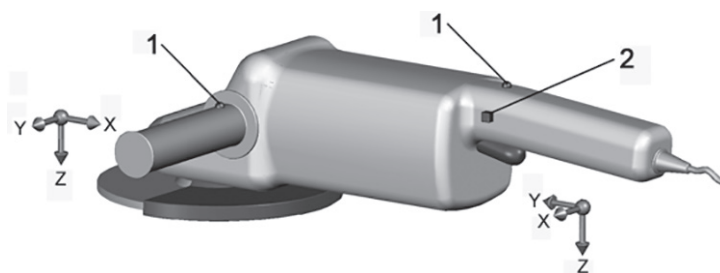

**Key**

- 1 prescribed location
- 2 secondary location

**Figure 7 — Measurement locations — Electrical angle grinder with separate main handle**

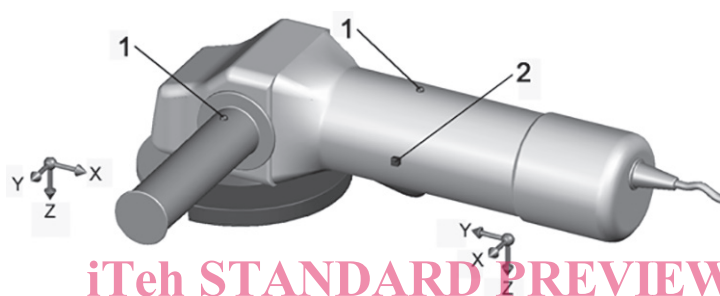

**iTeh STANDARD PREVIEW**  
(standards.iteh.ai)

**Key**

- 1 prescribed location
- 2 secondary location

ISO 28927-1:2019  
<https://standards.iteh.ai/catalog/standards/sist/9801bf2-8492-4786-bac3-1424143480/iso-28927-1-2019>

**Figure 8 — Measurement locations — Electrical angle grinder whose motor serves as main handle**

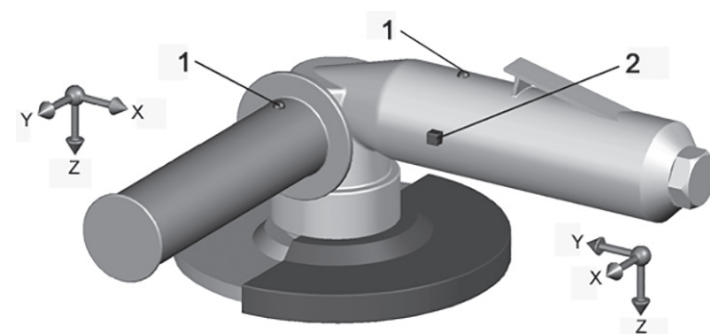

**Key**

- 1 prescribed location
- 2 secondary location

**Figure 9 — Measurement locations — Pneumatic angle grinder whose motor serves as main handle**