

DRAFT INTERNATIONAL STANDARD

ISO/DIS 24267

ISO/TC 216

Secretariat: UNE

Voting begins on:
2019-11-14

Voting terminates on:
2020-02-06

Friction — Test methods for casual footwear and components

ICS: 61.060

iTeh STANDARD PREVIEW
(standards.iteh.ai)
Full standard:
<https://standards.iteh.ai/catalog/standards/sist/42e71f9c-9f31-45d2-bd93-c2cd68f10b90/iso-dis-24267>

THIS DOCUMENT IS A DRAFT CIRCULATED FOR COMMENT AND APPROVAL. IT IS THEREFORE SUBJECT TO CHANGE AND MAY NOT BE REFERRED TO AS AN INTERNATIONAL STANDARD UNTIL PUBLISHED AS SUCH.

IN ADDITION TO THEIR EVALUATION AS BEING ACCEPTABLE FOR INDUSTRIAL, TECHNOLOGICAL, COMMERCIAL AND USER PURPOSES, DRAFT INTERNATIONAL STANDARDS MAY ON OCCASION HAVE TO BE CONSIDERED IN THE LIGHT OF THEIR POTENTIAL TO BECOME STANDARDS TO WHICH REFERENCE MAY BE MADE IN NATIONAL REGULATIONS.

RECIPIENTS OF THIS DRAFT ARE INVITED TO SUBMIT, WITH THEIR COMMENTS, NOTIFICATION OF ANY RELEVANT PATENT RIGHTS OF WHICH THEY ARE AWARE AND TO PROVIDE SUPPORTING DOCUMENTATION.

This document is circulated as received from the committee secretariat.

ISO/CEN PARALLEL PROCESSING



Reference number
ISO/DIS 24267:2019(E)

© ISO 2019

iTeh STANDARD PREVIEW
(standards.iteh.ai)

Full standard:
<https://standards.iteh.ai/catalog/standards/sist/42e71f9c-9f31-45d2-bd93-c2cd68f10b90/iso-dis-24267>



COPYRIGHT PROTECTED DOCUMENT

© ISO 2019

All rights reserved. Unless otherwise specified, or required in the context of its implementation, no part of this publication may be reproduced or utilized otherwise in any form or by any means, electronic or mechanical, including photocopying, or posting on the internet or an intranet, without prior written permission. Permission can be requested from either ISO at the address below or ISO's member body in the country of the requester.

ISO copyright office
CP 401 • Ch. de Blandonnet 8
CH-1214 Vernier, Geneva
Phone: +41 22 749 01 11
Fax: +41 22 749 09 47
Email: copyright@iso.org
Website: www.iso.org

Published in Switzerland

Contents

	Page
Foreword	iv
1 Scope	1
2 Principle	1
3 Normative references	1
4 Terms and definitions	1
5 Apparatus and materials	2
6 Sampling and conditioning	2
6.1 Sampling	2
6.2 Conditioning	2
7 Test method	3
7.1 Test modes and test conditions for footwear with low heel seat height	3
7.2 Test modes and test conditions for unit soles	3
7.3 Footwear or soles with heel and forepart moulded in one piece type 1	4
7.3.1 Samples with heel seat height lower than 80 mm	4
7.3.2 Samples with heel seat height higher than 80 mm	4
7.4 Footwear or soles with heel and forepart moulded in one piece type 2	5
7.5 Test on top pieces	6
7.6 Test on sheet materials	7
8 Test report	7
Annex A (normative) Preparation of footwear, sole units, top pieces and sliders	8

Foreword

ISO (the International Organization for Standardization) is a worldwide federation of national standards bodies (ISO member bodies). The work of preparing International Standards is normally carried out through ISO technical committees. Each member body interested in a subject for which a technical committee has been established has the right to be represented on that committee. International organizations, governmental and non-governmental, in liaison with ISO, also take part in the work. ISO collaborates closely with the International Electrotechnical Commission (IEC) on all matters of electrotechnical standardization.

The procedures used to develop this document and those intended for its further maintenance are described in the ISO/IEC Directives, Part 1. In particular, the different approval criteria needed for the different types of ISO documents should be noted. This document was drafted in accordance with the editorial rules of the ISO/IEC Directives, Part 2 (see www.iso.org/directives).

Attention is drawn to the possibility that some of the elements of this document may be the subject of patent rights. ISO shall not be held responsible for identifying any or all such patent rights. Details of any patent rights identified during the development of the document will be in the Introduction and/or on the ISO list of patent declarations received (see www.iso.org/patents).

Any trade name used in this document is information given for the convenience of users and does not constitute an endorsement.

For an explanation of the voluntary nature of standards, the meaning of ISO specific terms and expressions related to conformity assessment, as well as information about ISO's adherence to the World Trade Organization (WTO) principles in the Technical Barriers to Trade (TBT), see www.iso.org/iso/foreword.html.

This document was prepared by Technical Committee ISO/TC 216, *Footwear*.

Friction — Test methods for casual footwear and components

1 Scope

This method determines the coefficient of friction between footwear and floorings under conditions simulating those experienced in the phases of a typical walking step when slip is most likely to occur.

The method is applicable to all types of footwear, excepting professional footwear (EPI), outsole units, heel top pieces (top lifts) and sheet soling materials.

2 Principle

The footwear item and underfoot surface are brought into contact, subjected to a specified vertical force for a short period of static contact then moved horizontally relative to one another at a constant speed. The horizontal frictional force is measured at a given time after movement starts and the dynamic coefficient of friction is calculated for the particular conditions of the test.

3 Normative references

The following documents are referred to in the text in such a way that some or all of their content constitutes requirements of this document. For dated references, only the edition cited applies. For undated references, the latest edition of the referenced document (including any amendments) applies.

ISO 13287, *Personal protective equipment — Footwear — Test method for slip resistance*

4 Terms and definitions

For the purposes of this document, the following terms and definitions apply.

4.1

normal force

force applied to the surface through the footwear, perpendicular (90°) to the surface. The force includes the weight of the footwear, shoemaking last (4.1.1 or 4.1.2) or mechanical foot (4.1.3) and mounting

4.2

frictional force

force parallel to the surface and against the direction of movement arising when footwear slides over a surface

4.3

coefficient of friction CoF

ratio of the frictional force divided by the normal force

4.4

static contact time

time between initial contact of the footwear with the surface achieving a normal force of 50 N and the beginning of movement

4.5

measurement period

time interval during which the frictional force measurement is taken and during which the test conditions are satisfied

4.6

floor

material (flooring), without contaminant (lubricant), to be used as the test surface

4.7

surface

floor, with or without contaminant (lubricant), against which the footwear is tested

4.8

calibration test value CTV

coefficient of friction between the Slider 96 and the test surface

5 Apparatus and materials

Use apparatus and materials referred to in ISO 13287:2019, Chapter 4, with the following exceptions:

- Regarding standard shoemaking last, other lasts with the same dimensions of "STM603L lasts¹⁾" can also be used.
- Regarding test flooring surface, preferably use pressed ceramic tile, or the flooring called up in the relevant performance requirements. Suitable surfaces include EURO TILE 2 referred to in Annex B of ISO 13287:2019, other quarry tiles, vinyl, carpet or wood.

Additional materials/accessories needed to test samples according to 7.1 to 7.6:

- Cellulosic insole material of around 2 mm in thickness for testing soles which are going to be used in the footwear with an insole (for testing according to 7.1).
- Means to secure the soles to the last, as mechanical means, double sided adhesive tape, seal, adhesives, bands, etc. (for testing according to 7.1).
- Saw and/or sanding machine, for sample preparation (for testing according to 7.3).
- Mechanical systems to attach to the equipment spigot small-sized top-pieces, bigger top pieces, Slider 96 test piece or other testing samples to the testing machine, that can be used to replace the shoemaking lasts or mechanical foots (for testing according to 7.5).
- High-hardness rubber material of at least 50 mm × 50 mm (thickness of ≤ 2 mm), for small- sized top piece testing (for testing according to 7.5).
- Metallic plate made of e. g. aluminium, of at least (180 × 80) mm and 2,5 mm thick, for sheet material testing (for testing according to 7.6).

6 Sampling and conditioning

6.1 Sampling

Two samples shall be tested, right foot and left foot whenever possible, with the exception of top pieces where 2 test pieces shall be tested and sheet material where 2 test pieces shall be tested per direction.

6.2 Conditioning

The test items shall be conditioned prior to the test at (23 ± 2) °C and (50 ± 5) % RH for a minimum of 24 h. If necessary, the sample may be removed from this standard atmosphere provided that its temperature is maintained at (23 ± 2) °C, that testing starts within 30 min after removal from this standard atmosphere and that the testing is carried out at (23 ± 2) °C.

1) Estándar lasts supplied by SATRA.

7 Test method

7.1 Test modes and test conditions for footwear with low heel seat height

Test modes and conditions are those of EN ISO 13287.

Common contaminant conditions for daily footwear may be the following:

- Detergent solution according to ISO 13287:2019.
- Glycerol solution according to ISO 13287:2019.
- Water.
- Dry conditions (without contaminant).

7.2 Test modes and test conditions for unit soles

- Attach a 2 mm thick sheet of cellulosic material to the outsole simulating an insole. In special cases as "bio" soles (anatomical shape), that do not have an insole, do the test without the cellulosic material.
- Secure the mechanical foot firmly for the flat test mode, or secure the last for the heel or forepart test mode, using double sided adhesive tape or other mechanical means that do not affect the testing surface. The forepart area of the outsole shall always match the forefoot area of the last (see [Figure 1](#) for the particular case of testing soles in flat mode with artificial foot).
- In the heel test mode, avoid separation between the waist area of the sole and the waist area of the last over sliding, since the heel may be dragged backwards and flattened. Should this occur, use laces, adhesive tape or any other mechanical method to fasten the outsole and last waist areas together.
- Where the feather edge is not visible on the outsole and the position of the last upon the outsole (this information shall be provided by the test orderer) is unknown, place the last at 10 mm from the rear or front edge of the outsole, thus leaving the estimated space that the upper may fill.
- When the outsole matches several sizes, place the size of the last that best suits the outsole length following the indications in the previous paragraph, and report the last size used.
- Once the sample is ready, carry out the test according to the normal procedure described in chapter [7.1](#), using the vertical force according to the sample size.
- Is soles are those used in high heeled footwear, flat and heel mode can not be carried out.

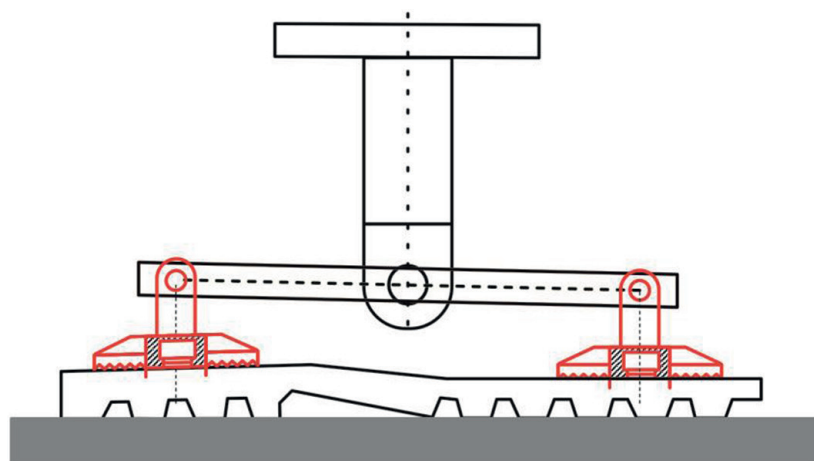

Figure 1 — Testing soles in flat mode with artificial foot

7.3 Footwear or soles with heel and forepart moulded in one piece type 1

In this footwear sole there is full contact with the floor in the waist area. See [Figure 2](#).

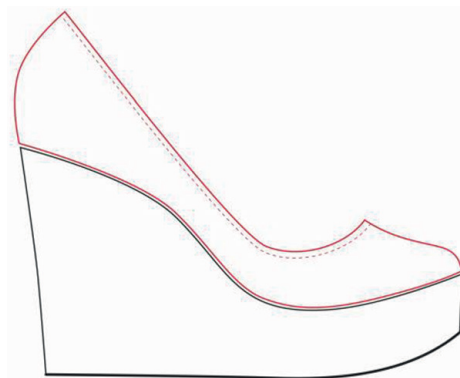

Figure 2 — Footwear sole type 1

7.3.1 Samples with heel seat height lower than 80 mm

- Carry out the test in flat mode conventionally with the mechanical foot, provided that it can be fitted. In these cases, the verticality of the central axis of the mechanical foot is lost, to a greater or lesser extent, depending on the heel elevation of the footwear. See [Figure 3](#).
- For the heel and forepart test modes, flatten the outsole by removing all of the heel elevation, by means of some machining method and proceed with the tests normally with the shoemaking last.
- When the footwear features a removable top piece, it may be removed carefully so as not to cause any damage and tested individually according to the procedure described for the test on top pieces ([7.5](#)).
- If samples are soles to be used in footwear with insole, carry out the tests with the 2-mm thick sheet of cellulosic material attached to the outsole simulating an insole, as described in [7.2](#).

7.3.2 Samples with heel seat height higher than 80 mm

- For the flat test mode, flatten the heel seat area of the outsole down to 80 mm, by means of some machining method and proceed with the test normally. To this end, when dealing with footwear, remove the upper to start with the process required. See [Figure 4](#).
- For the heel and forepart test modes, flatten the outsole by removing all of the heel elevation, by means of some machining method and proceed with the tests normally with the shoemaking last.
- When the footwear features a removable top piece, it may be removed carefully so as not to cause any damage and tested individually according to the procedure described for the test on top pieces ([7.5](#)).
- If samples are soles to be used in footwear with insole, carry out the tests with the 2 mm thick sheet of cellulosic material attached to the outsole simulating an insole, as described in [7.2](#).

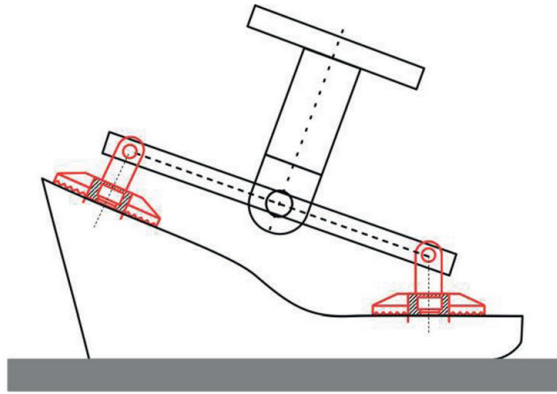

Figure 3 — Heel height lower than 80 mm

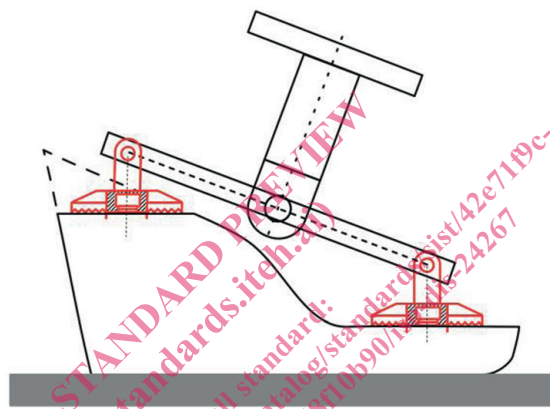

Figure 4 — Heel height higher than 80 mm

7.4 Footwear or soles with heel and forepart moulded in one piece type 2

In this footwear sole there is not full contact with the floor in the waist area. See [Figure 5](#).



Figure 5 — Footwear sole type 2

- If it is not possible to test in flat conditions according to [7.3.1](#) or [7.3.2](#), then this test mode cannot be carried out.
- Carry out the tests in heel and forepart test modes separately by splitting the shoe or the outsole at the waist, in two parts, and attaching the corresponding parts to the last using double sided adhesive tape.
- When the footwear features a removable top piece, it may be removed carefully so as not to cause any damage and tested individually according to the procedure described for the test on top pieces ([7.5](#)).