



Designation: D3043 – 00 (Reapproved 2011)

Standard Test Methods for Structural Panels in Flexure¹

This standard is issued under the fixed designation D3043; the number immediately following the designation indicates the year of original adoption or, in the case of revision, the year of last revision. A number in parentheses indicates the year of last reapproval. A superscript epsilon (ϵ) indicates an editorial change since the last revision or reapproval.

1. Scope

1.1 These test methods determine the flexural properties of strips cut from structural panels or panels up to 4 by 8 ft in size. Structural panels in use include plywood, waferboard, oriented strand board, and composites of veneer and of wood-based layers. Four methods of tests are included:

	Sections
Method A—Center-Point Flexure Test	5
Method B—Two-Point Flexure Test	6
Method C—Pure Moment Test	7
Method D—Flexure Test for Quality Assurance	8

The choice of method will be dictated by the purpose of the test, type of material, and equipment availability. All methods are applicable to material that is relative uniform in strength and stiffness properties. Only Method C should be used to test material suspected of having strength or stiffness variations within a panel caused by density variations, knots, knot-holes, areas of distorted grain, fungal attack, or wide growth variations. However, Method B may be used to evaluate certain features such as core gaps and veneer joints in plywood panels where effects are readily projected to full panels. Method C generally is preferred where size of test material permits. Moments applied to fail specimens tested by Method A, B or D in which large deflections occur can be considerably larger than nominal. An approximate correction can be made.

1.2 *Method A, Center-Point Flexure Test*—This method is applicable to material that is uniform with respect to elastic and strength properties. Total deflection, and modulus of elasticity computed from it, include a relatively constant component attributable to shear deformation. It is well suited to investigations of many variables that influence properties uniformly throughout the panel in controlled studies and to test small, defect-free control specimens cut from large panels containing defects tested by the large-specimen method.

1.3 *Method B, Two-Point Flexure Test*—This method, like Method A, is suited to the investigation of factors that influence

strength and elastic properties uniformly throughout the panel, in controlled studies, and to testing small, defect free control specimens cut from large specimens tested by Method C. However, it may be used to determine the effects of finger joints, veneer joints and gaps, and other features which can be placed entirely between the load points and whose effects can be projected readily to full panel width. Deflection and modulus of elasticity obtained from this method are related to flexural stress only and do not contain a shear component. Significant errors in modulus of rupture can occur when nominal moment is used (see [Appendix X1](#)).

1.4 *Method C, Pure Moment Test*—This method is ideally suited for evaluating effects of knots, knot-holes, areas of sloping grain, and patches for their effect on standard full-size panels. It is equally well suited for testing uniform or clear material whenever specimen size is adequate. Measured deformation and elastic constants are free of shear deformation effects; and panels can be bent to large deflections without incurring errors from horizontal force components occurring in other methods. Specimen size and span above certain minimums are quite flexible. It is preferred when equipment is available.

1.5 *Method D, Flexure Test for Quality Assurance*—This method, like Method A, is well suited to the investigation of factors that influence bending strength and stiffness properties. Also like Method A, this method uses small specimens in a center-point simple span test configuration. This method uses a span to depth ratio, specimen width, test fixture and test speed that make the method well suited for quality assurance. The method is frequently used for quality assurance testing of oriented strand board.

1.6 All methods can be used to determine modulus of elasticity with sufficient accuracy. Modulus of rupture determined by Methods A, B or D is subject to errors up to and sometimes exceeding 20 % depending upon span, loading, and deflection at failure unless moment is computed in the rigorous manner outlined in [Appendix X1](#) or corrections are made in other ways. These errors are not present in Method C.

1.7 When comparisons are desired between results of specimen groups, it is good practice to use the same method of test for all specimens, thus eliminating possible differences relative to test method.

¹ These methods are under the jurisdiction of ASTM Committee D07 on Wood and are the direct responsibility of Subcommittee D07.03 on Panel Products.

Current edition approved Nov. 1, 2011. Published November 2011. Originally approved in 1972. Last previous edition approved in 2000 as D3043 – 00 (2006). DOI: 10.1520/D3043-00R11.

1.8 This standard does not purport to address all of the safety concerns, if any, associated with its use. It is the responsibility of the user of this standard to establish appropriate safety and health practices and determine the applicability of regulatory limitations prior to use.

2. Referenced Documents

2.1 ASTM Standards:²

D2395 Test Methods for Density and Specific Gravity (Relative Density) of Wood and Wood-Based Materials

D4442 Test Methods for Direct Moisture Content Measurement of Wood and Wood-Based Materials

D4761 Test Methods for Mechanical Properties of Lumber and Wood-Base Structural Material

3. Significance and Use

3.1 These methods give the flexural properties, principally strength and stiffness, of structural panels. These properties are of primary importance in most structural uses of panels whether in construction for floors, wall sheathing, roof decking, concrete form, or various space plane structures; packaging and materials handling for containers, crates, or pallets; or structural components such as stress-skin panels.

3.2 To control or define other variables influencing flexure properties, moisture content and time to failure must be determined. Conditioning of test material at controlled atmospheres to control test moisture content and determination of specific gravity are recommended. Comparisons of results of plywood, veneer composites, and laminates with solid wood or other plywood constructions will be greatly assisted if the thickness of the individual plies is measured to permit computation of section properties.

4. Control of Moisture Content

4.1 Structural panel samples to be tested at a specific moisture content or relative humidity shall be conditioned to approximate constant mass in controlled atmospheric conditions before testing. For structural panels used under dry conditions, a relative humidity of $65 \pm 5\%$ at a temperature of $68 \pm 6^\circ\text{F}$ ($20 \pm 3^\circ\text{C}$) is recommended.

5. Method A—Center-Point Flexure Test

5.1 *Summary*—A conventional compression testing machine is used to apply and measure a load at mid-span of a small flexure specimen; and the resulting deflection at mid span is measured or recorded. The test proceeds at a constant rate of head motion until either sufficient deflection data in the elastic range have been gathered or until specimen failure occurs. The specimen is supported on reaction bearings which permit the specimen and bearing plate to roll freely over the reactions as the specimen deflects.

5.2 *Test Specimen*—The test specimen shall be rectangular in cross section. The depth of the specimen shall be equal to the

thickness of material, and the width shall be 1 in. (25 mm) for depths less than $\frac{1}{4}$ in. (6 mm) and 2 in. (50 mm) for greater depths (**Note 1**). When the principal direction of the face plies, laminations, strands, or wafers is parallel to the span, the length of the specimen (**Note 2**) shall be not less than 48 times the depth plus 2 in.; when the principal direction of the face plies, laminations, strands, or wafers is perpendicular to the span, the specimen length shall be not less than 24 times the depth plus 2 in. (**Note 3**).

NOTE 1—In certain specific instances, it may be necessary or desirable to test specimens having a width greater than 1 or 2 in. (25 or 50 mm). To eliminate plate action when wider specimens are tested, the specimen width shall not exceed one third of the span length and precaution shall be taken to ensure uniform bearing across the entire width of the specimen at the load and reaction points.

NOTE 2—In cutting specimens to meet the length requirement, it is not intended that the length be changed for small variations in thickness. Rather, it is intended that the nominal thickness of the material under test should be used for determining the specimen length.

5.2.1 *Measurements*—Measure specimen thickness at mid-span at two points near each edge and record the average. Measure to the nearest 0.001 in. (0.02 mm) or 0.3 %. Measure width at mid-span to the nearest 0.3 %.

5.2.1.1 When needed for interpretation of test results for plywood, veneer composites, and laminates measure thickness of each layer to the nearest 0.001 in. (0.02 mm) at mid-span at each edge and record the average.

5.3 *Span*—The span shall be at least 48 times the nominal depth when the principal direction of the face plies, laminations, strands, or wafers of the test specimen is parallel to the span and at least 24 times the nominal depth when the principal direction of the face plies, laminations, strands, or wafers is perpendicular to the span (**Note 3**).

NOTE 3—Establishment of a span-depth ratio is required to allow an accurate comparison of test values for materials of different thicknesses. It should be noted that the span is based on the nominal thickness of the material and it is not intended that the spans be changed for small variations in thickness.

5.4 *End Supports*—Reaction points shall be capable of freely compensating for warp of the test specimen by turning laterally in a plane perpendicular to the specimen length so as to apply load uniformly across its width. Design of end supports shall place the center of rotation near the neutral axis of the specimen of average thickness. Construction is shown in detail in **Fig. 1**. Bearing points shall be rounded where they contact the specimen.

5.4.1 Use of bearing plates is generally recommended and is required wherever significant local deformation may occur.

5.4.2 Use of roller bearings or plates and rollers to preclude friction forces between end support and specimen is recommended in addition to the requirement of lateral compensation. Construction of a suitable end support using small roller bearings in conjunction with a plate which clips to the end of the specimen is illustrated in **Fig. 2** and **Fig. 3**. The use of a large ball bearing to provide lateral compensation for warp is also illustrated. This method is particularly recommended for thin specimens and small loads.

5.4.3 As the specimen deflects during test, loads no longer act in the direction assumed in formulas for calculating

² For referenced ASTM standards, visit the ASTM website, www.astm.org, or contact ASTM Customer Service at service@astm.org. For *Annual Book of ASTM Standards* volume information, refer to the standard's Document Summary page on the ASTM website.

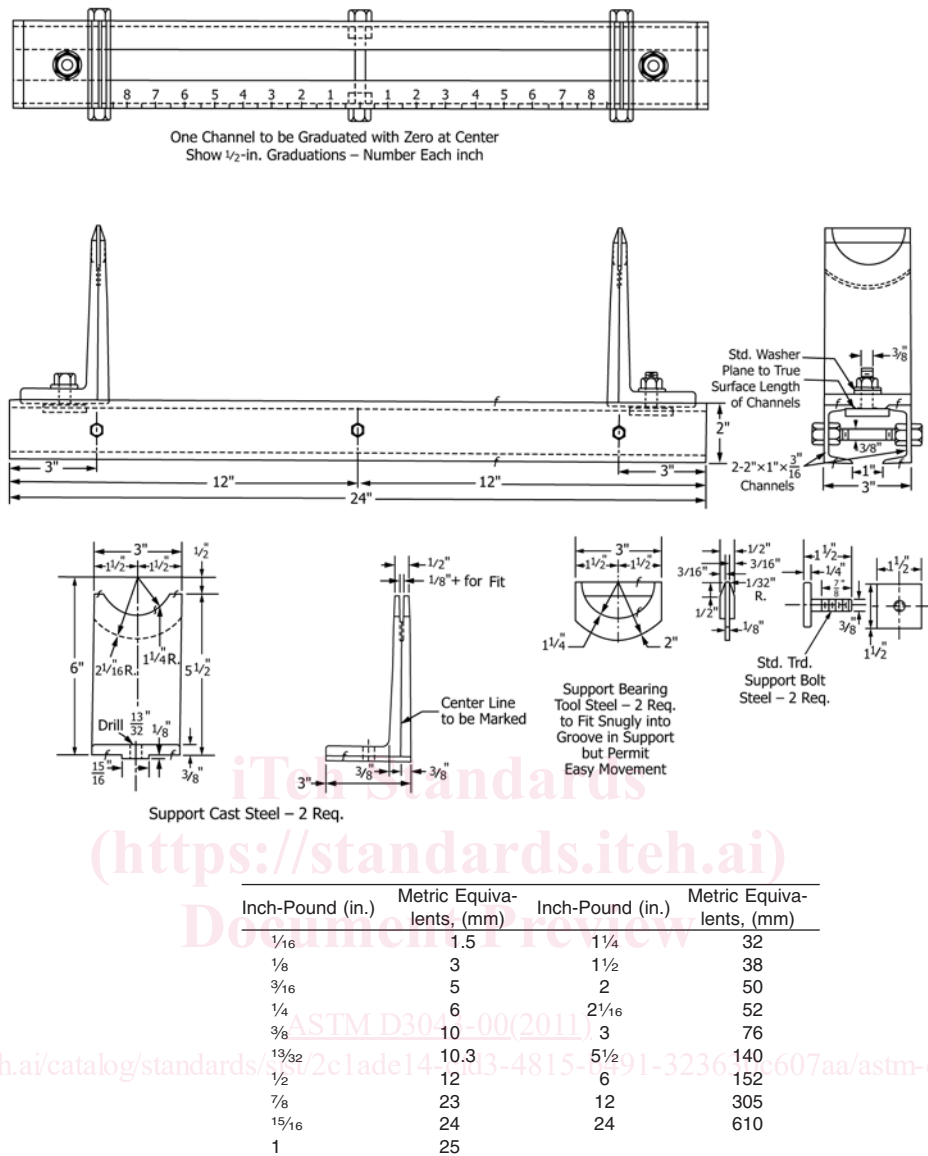

FIG. 1 Apparatus for Static Bending Test Showing Details of Laterally Adjustable Supports

properties. For a discussion of these errors, their effects, and methods for reducing them, refer to **Appendix X1**.

5.5 Loading Block—A loading block having a radius of curvature of approximately one and one-half times the depth of the test specimen for a chord length of not less than twice the depth of the specimen shall be used. In cases where excessive local deformation may occur, suitable bearing plates shall be used. Radius of curvature of bearing plate or block shall not be so large as to cause bridging as the specimen bends.

5.6 Loading Procedure—Apply the load with a continuous motion of the movable head throughout the test. The rate of load application shall be such that the maximum fiber strain rate is equal to 0.0015 in./in. (mm/mm) per min within a

permissible variation of $\pm 25\%$. Load shall be measured to an accuracy of $\pm 1\%$ of indicated value or 0.4 percent of full scale, whichever is larger. Calculate the rate of motion of the movable head as follows:

$$N = zL^2/6d \quad (1)$$

where:

- N = rate of motion of moving head, in./min (mm/min),
- L = span, in. (mm),
- d = depth of beam, in. (mm), and
- z = unit rate of fiber strain, in./in.·min (mm/mm·min) of outer fiber length = 0.0015.

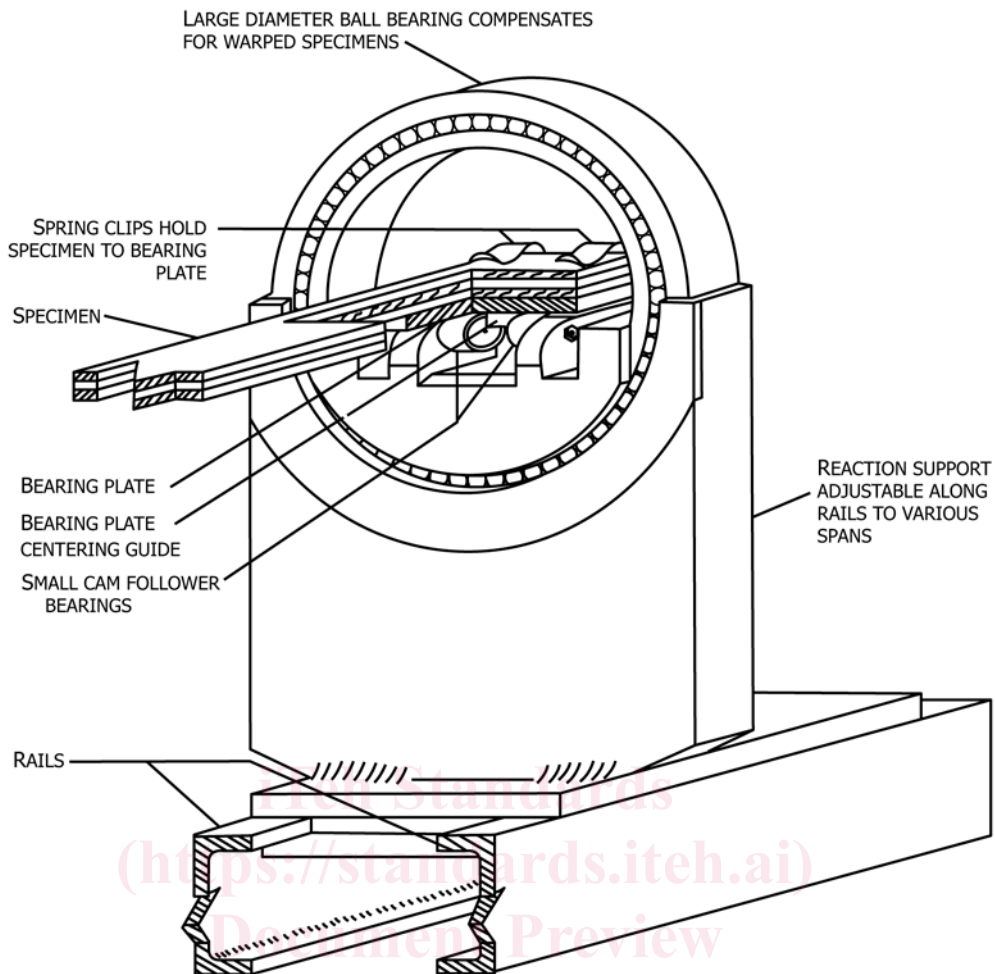

FIG. 2 Reaction Bearing for Small Flexure Test Specimens

5.6.1 Measure the elapsed time from initiation of loading to maximum load and record to the nearest 1/2 min.

5.7 *Measurement of Deflection*—Take data for load-deflection curves to determine the modulus of elasticity, proportional limit, work to proportional limit, work to maximum load, and total work. Take deflections by the methods indicated in Fig. 4 or Fig. 5, and take readings to the nearest 0.001 in. (0.02 mm). Choose increments of load so that not less than 12 and preferably 15 or more readings of load and deflection are taken to the proportional limit.

5.7.1 Deflections also may be measured with transducer-type gages and plotted simultaneously against load. In this case, record deflection to an accuracy of at least 1 1/2 % of deformation at proportional limit and the recorded trace below the proportional limit shall be at least 2 1/2 in. (64 mm) long or 1/4 of full scale measured on the deformation axis, whichever is larger. Similar requirements apply to the load axis.

5.8 *Calculations:*

5.8.1 Calculate specimen bending stiffness as follows:

$$EI = (L^3 / 48)(P/\Delta) \quad (2)$$

where:

EI = modulus of elasticity, psi (MPa) × moment of inertia, in.⁴ (or mm⁴),

P/Δ = slope of load—deflection curve, lbf/in. (N/mm),

I = moment of inertia, in.⁴ (mm⁴), and

L = span, in. (mm).

5.8.1.1 Moment of inertia used in the computations in 5.8.1 may be calculated in several different ways depending upon the requirements of the investigation. It may be based on the entire cross section, may include only the moment of inertia of layers parallel to span, or may include all layers weighted in accordance with modulus of elasticity in the direction of bending stress. State clearly the method employed in the report.

5.8.2 Calculate maximum moment ($S_b I/c$) by the following equation:

$$S_b I/c = PL/4 \quad (3)$$

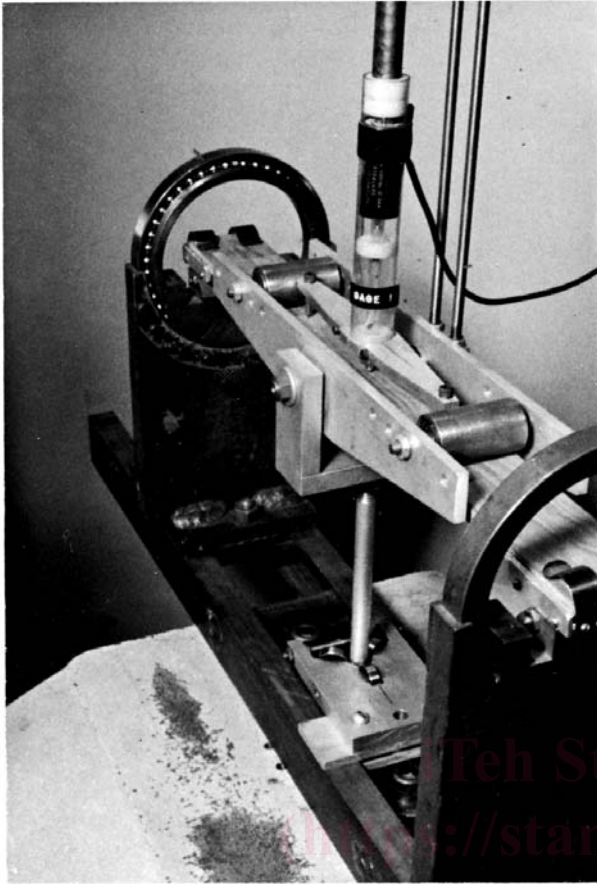

FIG. 3 Apparatus for Two-Point Loading and Measurement of Deflection (Method B)

where:

- $S_b I/c$ = maximum moment, lbf-in. (N-mm),
- S_b = modulus of rupture, psi (MPa),
- P = maximum load, lbf (N), and
- c = distance from neutral axis to extreme fiber, in. (mm).

6. Method B—Two-Point Flexure Test

6.1 *Summary*—The ends of a two-point flexure specimen are supported on special reaction bearings which in turn rest on the table of a conventional testing machine. A pivoted loading device applies equal loads at points $1/4$ of span from the reactions resulting from downward motion of the testing machine crosshead, and subjects the middle half of the specimen to conditions of nearly pure moment. Deflection of mid span relative to two points just inside the load points is measured with a dial gage or transducer thus giving deformation due to pure bending and unaffected by shear deformation.

6.2 *Test Specimen*—The test specimen shall be rectangular in cross section and its length shall exceed by 2 in. (50 mm) the span on which it is to be tested as determined in 6.3. Thickness shall be the thickness of the material. Width shall be 1 in. (25 mm) for material less than $1/4$ in. (6 mm) thick and 2 in. for material $1/4$ in. and over in thickness. The alternate width is 12 in. (300 mm).

6.2.1 *Measurements*—Measure specimen thickness at mid-span at two points near each edge and record the average. Measurements shall be to the nearest 0.001 in. (0.02 mm) or 0.3 %. Measure width at mid-span to the nearest 0.3 %.

6.2.1.1 When needed for interpretation of test results for plywood, veneer composites, and laminates, measure thickness of each layer to the nearest 0.001 in. (0.02 mm) at mid-span at each edge and record the average.

6.3 *Span*—Span-depth ratio has relatively little influence on the results of tests using two-point loading and the method of measuring deformation described for it in this standard. However, it is important that the distance between load point and adjacent support be sufficient to prevent rolling shear failures. The alternate 12-in. (300-mm) width will have a midlength (constant moment section) at least 12 in. in length.

6.3.1 Specimens tested for stiffness only shall have a span at least 48 times nominal thickness if the principal direction is parallel to span and 24 times nominal thickness if the principal direction is perpendicular to span.

6.3.2 It is recommended that two-point loading tests to failure be made on a span at least equal to the spacing between load points plus 48 times specimen thickness or 24 times specimen thickness for the principal direction parallel or perpendicular respectively. Material having high rolling shear strength or having all its plies, laminations, strands, or wafers parallel to span may use closer spacing between loads and supports.

6.4 *Supports*—Reaction supports shall meet the requirements of 5.4 and 5.4.1. Other comments as well as those of 5.4.2 and 5.4.3 apply.

6.5 *Loading*—Apply two equal loads to the specimen equidistant from the supports by cylindrical surfaces having a radius of curvature of at least $1\frac{1}{2}$ times specimen thickness wherever it may contact the specimen. The axes of these surfaces shall remain parallel and at least one of them shall be free to turn about its axis or be loaded through rollers to prevent the application of friction forces to the surface of the specimen. Construction of a satisfactory loading head is illustrated in Fig. 6 and Fig. 3. Locate the pivot point that equalizes the two loads near the original neutral axis of the specimen.

6.5.1 Space load points sufficiently to provide a deflection which can be adequately measured. A spacing of at least 24 and 12 times specimen thickness is recommended for specimens with the principal direction parallel and perpendicular to span respectively.

6.5.2 Measure the sum of the two loads to an accuracy of at least 1 % of indicated value or 0.4 % of full scale, whichever is larger.

6.6 *Speed of Test*—Apply load at a continuous rate of motion of the load points with respect to the supports within a permissible range of 25 % of the rate determined as follows:

$$N = (za/3d)(3L - 4a) \quad (4)$$

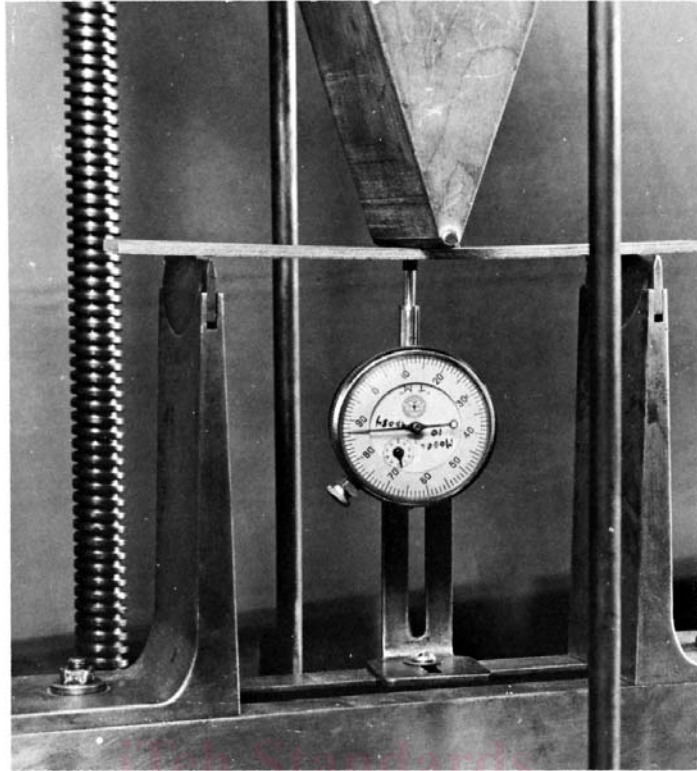

FIG. 4 Static Bending Test Showing Adjustable Supports and One Method of Attaching Dial Gage for Observing Deflection of Thin Material

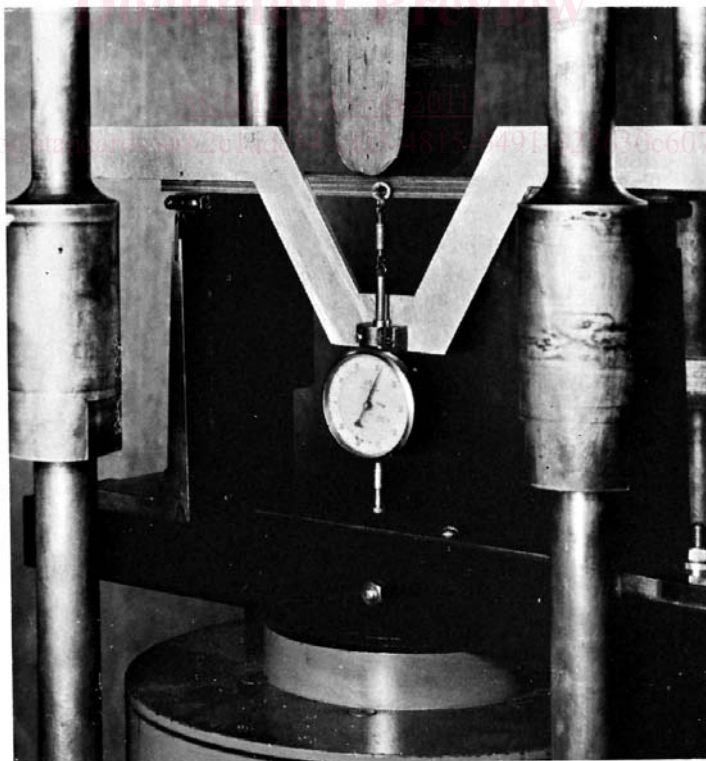

FIG. 5 Static Bending Test Showing Roller Bearing at Supports and Special Yoke with Dial Gage for Measuring Deflection at the Neutral Axis