



Designation: D3454 – 11

Standard Test Method for Radium-226 in Water¹

This standard is issued under the fixed designation D3454; the number immediately following the designation indicates the year of original adoption or, in the case of revision, the year of last revision. A number in parentheses indicates the year of last reappraisal. A superscript epsilon (ϵ) indicates an editorial change since the last revision or reappraisal.

1. Scope

1.1 This test method covers the measurement of soluble, suspended, and total radium-226 in water in concentrations above 3.7×10^{-3} Bq/L. This test method is not applicable to the measurement of other radium isotopes.

1.2 This test method may be used for quantitative measurements by calibrating with a radium-226 standard, or for relative measurements by comparing the measurements made with each other.

1.3 This test method does not meet the current requirements of Practice [D2777](#).

1.4 The values stated in SI units are to be regarded as the standard. The inch-pound units given in parentheses are for information only.

1.5 Hydrofluoric acid (HF) is very hazardous and should be used in a well-ventilated hood. Wear rubber gloves, safety glasses or goggles, and a laboratory coat. Avoid breathing any HF fumes. Clean up all spills promptly and wash thoroughly after using HF.

1.6 *This standard does not purport to address all of the safety concerns, if any, associated with its use. It is the responsibility of the user of this standard to establish appropriate safety and health practices and determine the applicability of regulatory limitations prior to use.*

2. Referenced Documents

2.1 *ASTM Standards:*²

[D1129 Terminology Relating to Water](#)

[D1193 Specification for Reagent Water](#)

[D2777 Practice for Determination of Precision and Bias of Applicable Test Methods of Committee D19 on Water](#)

[D3370 Practices for Sampling Water from Closed Conduits](#)

¹ This test method is under the jurisdiction of ASTM Committee [D19](#) on Water and is the direct responsibility of Subcommittee [D19.04](#) on Methods of Radiochemical Analysis.

Current edition approved June 15, 2011. Published July 2011. Originally approved in 1975. Last previous edition approved in 2005 as D3454 – 05. DOI: 10.1520/D3454-11.

² For referenced ASTM standards, visit the ASTM website, www.astm.org, or contact ASTM Customer Service at service@astm.org. For *Annual Book of ASTM Standards* volume information, refer to the standard's Document Summary page on the ASTM website.

[D3648 Practices for the Measurement of Radioactivity](#)
[D3649 Practice for High-Resolution Gamma-Ray Spectrometry of Water](#)
[D3856 Guide for Management Systems in Laboratories Engaged in Analysis of Water](#)
[D4448 Guide for Sampling Ground-Water Monitoring Wells](#)
[D5847 Practice for Writing Quality Control Specifications for Standard Test Methods for Water Analysis](#)
[D6001 Guide for Direct-Push Groundwater Sampling for Environmental Site Characterization](#)
[D7282 Practice for Set-up, Calibration, and Quality Control of Instruments Used for Radioactivity Measurements](#)

3. Terminology

3.1 For definitions of terms used in this test method, refer to Terminology [D1129](#). For terms not defined in this test method or in Terminology [D1129](#), reference may be made to other published glossaries.

4. Summary of Test Method

4.1 This test method³ is based on the emanation and scintillation counting of ²²²Rn, a gaseous daughter product of ²²⁶Ra, from a solution.

4.2 ²²⁶Ra is collected from water by coprecipitation on a relatively large amount of barium sulfate. The barium-radium sulfate is decomposed by fuming with phosphoric acid, and the resulting glassy melt is dissolved by evaporation with dilute hydrochloric acid to form soluble barium-radium phosphates and chlorides. These salts are dissolved and the solution is stored for ingrowth of ²²²Rn. After a suitable ingrowth period, the radon gas is removed from the solution by purging with gas and transferred to a scintillation counting chamber. About 4 h after ²²²Rn collection, the scintillation chamber is counted for alpha activity. The ²²⁶Ra concentration is calculated from the alpha count rate of ²²²Rn and its immediate daughters. The radioactive decay characteristics of ²²⁶Ra and its immediate decay progeny are listed in [Table 1](#).

³ This test method is based on a previously published method by Rushing, D.E., Garcia, W.J., and Clark, D.A. "The Analysis of Effluents and Environmental Samples from Uranium Mills and of Biological Samples for Radium, Polonium and Uranium," Radiological Health and Safety in Mining and Milling of Nuclear Materials, Vol. II, IAEA, Vienna, Austria, 1964), p. 187.

TABLE 1 Radioactive Decay Characteristics of Radium-226 and Its Daughters

Radionuclide	Half-life	Mode of Decay
²²⁶ Ra	1600 years	α
²²² Rn	3.82 days	α
²¹⁸ Po	3.10 min	α
²¹⁴ Pb	26.8 min	β, γ
²¹⁴ Bi	19.9 min	β, γ
²¹⁴ Po	164/3 μ s	α
²¹⁰ Pb	22.2 years	β, γ

5. Significance and Use

5.1 The most prevalent of the five radium isotopes in ground water, having a half life greater than one day, are ²²⁶Ra and ²²⁸Ra. These two isotopes also present the greatest health risk compared to the other naturally occurring nuclides of equal concentrations if ingested via the water pathway.

5.2 Although primarily utilized on a water medium, this technique may be applicable for the measurement of the ²²⁶Ra content of any media once the medium has been completely decomposed and put into an aqueous solution.

5.3 The general methodology and basis of this technique are similar to the methodology “²²⁶Ra in Drinking Water (Radon Emanation Technique)” as described in the document EPA-600/4-80-032.⁴

6. Interferences

6.1 Only the gaseous alpha-emitting radionuclides interfere, namely, ²¹⁹Rn and ²²⁰Rn. Their half lives are 3.9 s and 54.5 s respectively; their presence indicates the presence of their parents, ²²³Ra and ²²⁴Ra. These short-lived radon isotopes decay before the ²²²Rn is counted; it is their alpha-emitting decay products that would interfere. These interferences are very rare in water samples but are frequently observed in certain uranium mill effluents.

7. Apparatus

7.1 *Radon Bubbler*⁵(Fig. 1).

7.2 *Radon Scintillation Chamber* (also known as Lucas Cell) (Fig. 2).

7.3 *Manometer*, open-end capillary tube or vacuum gage having a volume which is small compared to the volume of the scintillation chamber, 0 – 760 mm Hg (Fig. 3).

7.4 *Gas Purification Tube*, 7 to 8 mm outside diameter standard wall glass tubing, 100 mm long, constricted at lower end to hold a glass wool plug (Fig. 3). The upper half of the tube is filled with magnesium perchlorate and the lower half with a sodium hydrate-asbestos absorbent.

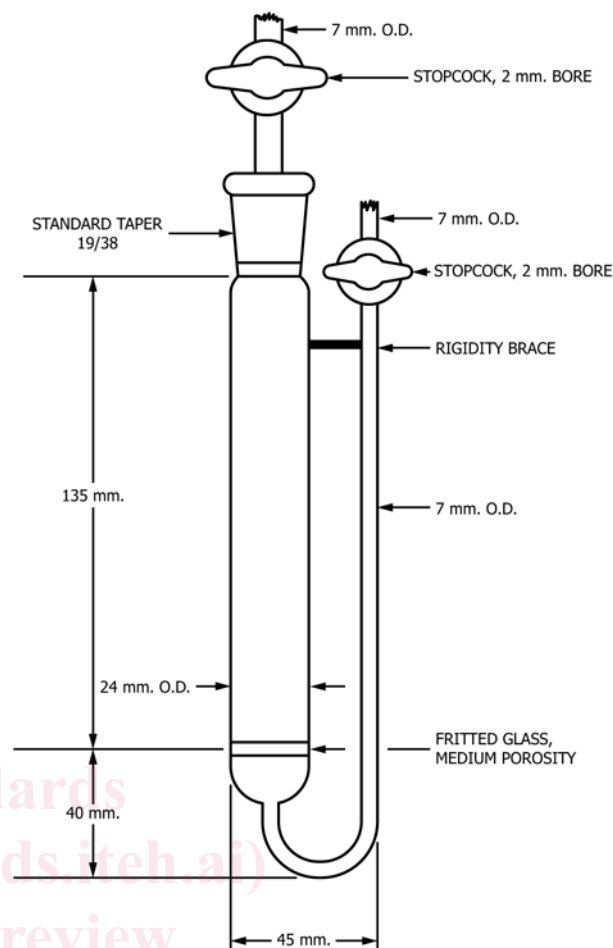

FIG. 1 Radon Bubbler

7.5 *Scintillation Counter Assembly*, consisting of a 50 mm (2 in.) or more in diameter photomultiplier tube mounted in a light-tight housing and coupled to the appropriate preamplifier, high-voltage supply, and scaler. A high-voltage safety switch should open automatically when the light cover is removed to avoid damage to the photomultiplier tube. The preamplifier should incorporate a variable gain adjustment. The counter should be equipped with a flexible ground wire which is attached to the chassis photomultiplier tube by means of an alligator clip or similar device. The operating voltage is ascertained by determining a plateau using ²²²Rn in the scintillation chamber as the alpha source. The slope of the plateau should not exceed 2 %/100 V. The counter and the scintillation chamber should be calibrated and used as a unit when more than one counter is available. The background counting rate for the counter assembly without the scintillation chamber should range from 0.00 to 0.0005 s⁻¹.

7.6 *Membrane Filters*, 0.45 μm pore size.

7.7 *Silicone Grease*, high-vacuum, for bubbler stopcocks.

7.8 *Platinum Ware*, crucibles, 20 to 30 mL, and one 500 mL capacity dish. Platinum ware is cleaned by immersing and rotating in a molten bath of potassium pyrosulfate, removing, cooling, and rinsing in hot tap water, digesting in hot 6M HCl, rinsing in water, and finally flaming over a burner.

⁴ “Radium-226 in Drinking Water (Radon Emanation Technique),” *Prescribed Procedures for Measurement of Radioactivity in Drinking Water*, August 1980.

⁵ The sole source of supply of the radon bubbler known to the committee at this time is Corning Glass Works, Special Sales Section, Corning, N.Y. 11830. If you are aware of alternative suppliers, please provide this information to ASTM International Headquarters. Your comments will receive careful consideration at a meeting of the responsible technical committee.

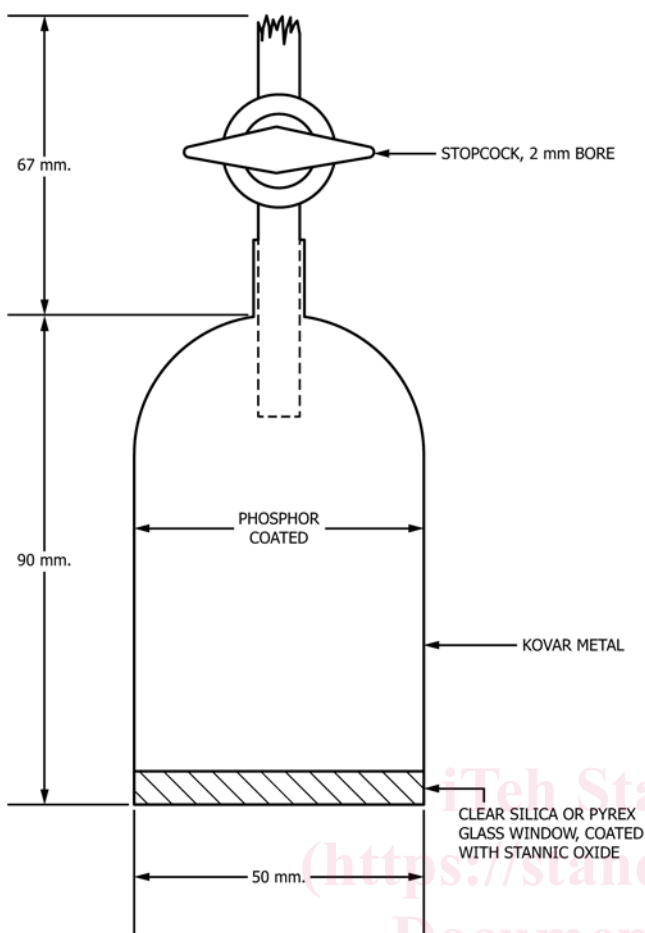

FIG. 2 Radon Scintillation Chamber

7.9 *Laboratory Glassware*—Glassware may be decontaminated before and between uses by heating for 1 h in EDTA- Na_2CO_3 decontaminating solution at 90 to 100°C, then rinsing in water, in 1M HCl and again in water.

8. Reagents and Materials

8.1 *Purity of Reagents*—Reagent grade chemicals shall be used in all tests. Unless otherwise indicated, it is intended that all reagents shall conform to the specifications of the Committee on Analytical Reagents of the American Chemical Society.⁶ Other grades may be used, provided it is first ascertained that the reagent is of sufficiently high purity to permit its use without lessening the accuracy of the determination.

8.2 *Purity of Water*—Unless otherwise indicated, reference to water shall be understood to mean conforming to Specification D1193, Type III.

8.3 *Radioactive Purity of Reagents*—Radioactive purity shall be such that the measured results of blank samples do not

⁶ "Reagent Chemicals, American Chemical Society Specifications," Am. Chemical Soc., Washington, DC. For suggestions on testing of reagents not listed by the American Chemical Society, see "Analar Standards for Laboratory Chemicals," BDH Ltd., Poole, Dorset, U.K., and the "United States Pharmacopeia," and National Formulary, U.S. Pharmaceutical Convention, Inc. (USPC), Rockville, MD.

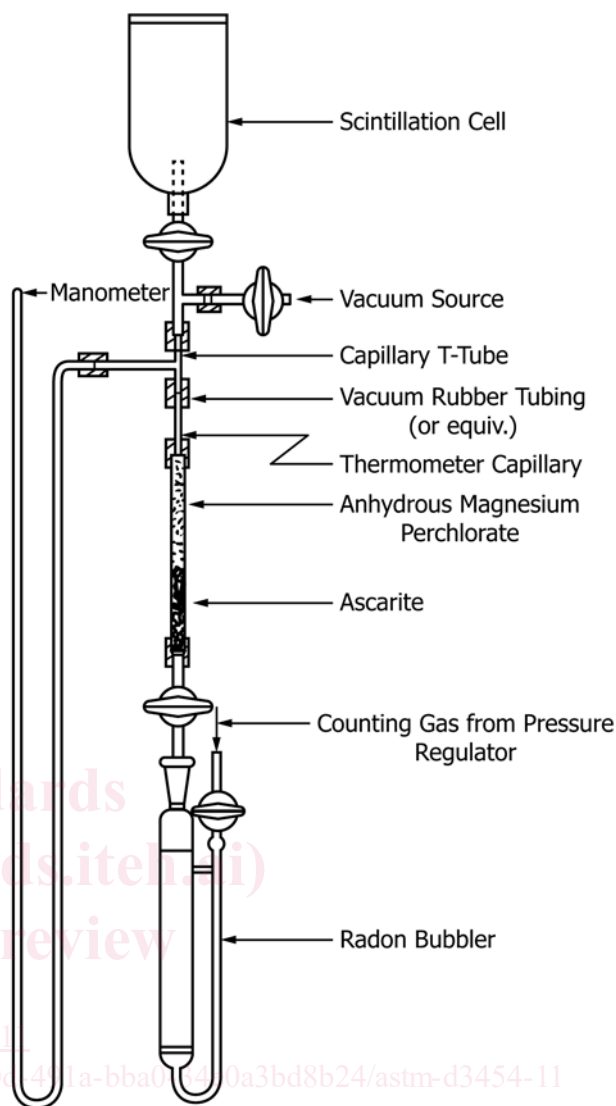

FIG. 3 De-emanation Assembly

exceed the calculated probable error of the measurement or are within the desired precision.

8.4 *Ammonium Sulfate Solution (100 g/L)*—Dissolve 10 g of ammonium sulfate ($(\text{NH}_4)_2\text{SO}_4$) in water and dilute to 100 mL.

8.5 *Barium Chloride Carrier Solution Stock, (17.8 g/L)*—Dissolve 17.8 g of barium chloride ($\text{BaCl}_2 \cdot 2\text{H}_2\text{O}$) in water and dilute to 1 L. This solution will contain 10 mg/mL Ba^{++} .

8.6 *Barium-133 Tracer Solution*—(approximately 3 kBq/mL).

8.7 *Barium Chloride Carrier Solution, Working*—Add 100 mL of barium chloride carrier stock solution and 10 mL of barium-133 tracer solution to 890 mL of water and mix thoroughly. This solution will contain approximately 1 g/L of Ba^{++} . Allow to stand for 24 h and filter through a membrane filter.

8.8 *EDTA-Sodium Carbonate Decontaminating Solution*—Dissolve 10 g of disodium ethylenediaminetetraacetate and 10 g of sodium carbonate (Na_2CO_3) in water and dilute to 1 L.

8.9 *Flux*—To a large platinum dish (about 500-mL capacity) add 30 mg of BaSO₄, 65.8 g of K₂CO₃, 50.5 g of Na₂CO₃, and 33.7 g of Na₂B₄O₇·10 H₂O. Mix well and heat cautiously until the water is expelled; fuse and mix thoroughly by swirling. Cool flux, grind it in a porcelain mortar to pass a U. S. Standard No. 10 (2.00-mm) (or finer) sieve. Store in an airtight bottle. (Flux can be prepared in smaller batches.)

8.10 *Hydrochloric Acid (sp gr 1.19)*—Concentrated hydrochloric acid (HCl).

8.11 *Hydrochloric Acid Solution 6M (1 + 1)*—Mix 1 volume of concentrated HCl (sp gr 1.19) with 1 volume of water.

8.12 *Hydrochloric Acid Solution 1M (1 + 11)*—Mix 1 volume of concentrated HCl (sp gr 1.19) with 11 volumes of water.

8.13 *Hydrochloric Acid Solution 0.24M (1 + 49)*—Mix 1 volume of concentrated HCl (sp gr 1.19) with 49 volumes of water.

8.14 *Hydrochloric Acid Solution 0.1M (1 + 119)*—Mix 1 volume of concentrated HCl (sp gr 1.19) with 119 volumes of water.

8.15 *Hydrofluoric Acid (sp gr 1.15)*—Concentrated hydrofluoric acid (HF). Use extreme caution.

8.16 *Hydrogen Peroxide 3 % (1 + 9)*—Mix 1 volume of H₂O₂ (30 %) with 9 volumes of water.

8.17 *Magnesium Perchlorate*—Anhydrous magnesium perchlorate Mg(ClO₄)₂.

8.18 *Phosphoric Acid (sp gr 1.69)*—Concentrated phosphoric acid (H₃PO₄).

8.19 *Radium Standard Solution (0.37 Bq/mL)*.^{5,7}

8.20 *Sodium Hydroxide-Coated Silicate Absorbent, Proprietary*,^{5,8} 8 to 20 mesh.

8.21 *Sulfuric Acid (sp gr 1.84)*—Concentrated sulfuric acid (H₂SO₄).

8.22 *Sulfuric Acid Solution 0.05M (1 + 359)*—Mix 1 volume of concentrated H₂SO₄ (sp gr 1.84) with 359 volumes of water. This solution is 0.1 N. Slowly add acid to water.

8.23 *Helium*, in a high-pressure cylinder with a two-stage pressure regulator and needle valve.

9. Sampling

9.1 Collect the sample in accordance with the applicable standards as described in Practices **D3370**.

10. Calibration and Standardization

10.1 Close the inlet stopcock of a bubbler, (**Note 1**) add 5 mL of BaCl₂·2H₂O carrier solution, 1 mL of concentrated HCl (sp gr 1.19), 3 mL (1.11 Bq) of standard radium solution and fill the bubbler ²/₃ to ³/₄ full with water.

NOTE 1—Before using, test bubblers by placing about 10 mL of water in them and passing air through them at the rate of 3 to 5 mL/min. This should form many fine bubbles rather than a few large ones. Do not use bubblers requiring excessive pressure to initiate bubbling. Reject unsatisfactory bubblers. Corning's "medium-porosity" fritted glass disks are usually satisfactory.

10.2 Insert the outlet stopcock into the bubbler with the stopcock open. Adjust the helium regulator (diaphragm) valve so that a very slow stream of gas will flow with the needle valve open. Attach the helium supply to the inlet of bubbler and adjust the inlet pressure to produce a froth a few millimetres thick. Establish a zero ingrowth time by purging the liquid with helium for 15 to 20 min.

10.3 In rapid succession, close the inlet stopcock, remove the gas connection, and the close outlet stopcock. Record the date and time and store the bubbler preferably for 2 to 3 weeks before collecting and counting the ²²²Rn.

10.4 Attach a scintillation chamber as shown in **Fig. 3**; substitute a glass tube with a stopcock for the bubbler so that the helium gas can be turned on and off conveniently. Open the stopcock on the scintillation chamber; close the stopcock to the gas and gradually open the stopcock to vacuum source to evacuate the cell. Close the stopcock to the vacuum source and check the manometer reading for 2 min to test the system, especially the scintillation chamber for leaks. If leaks are detected they should be identified and sealed.

10.5 Open the stopcock to the helium gas and allow the gas to enter the chamber slowly until atmospheric pressure is reached. Close all the stopcocks.

10.6 Place the scintillation chamber on the photomultiplier tube (in a light-tight housing), wait 10 min, and obtain a background count rate (preferably over a period of at least 100 min). Phototube must not be exposed to external light with the high voltage applied.

10.7 With the scintillation chamber and bubbler in positions indicated in **Fig. 3** and all stopcocks closed, open the stopcock to vacuum and then to the scintillation chamber. Evacuate the scintillation cell and the gas purification system. Close the stopcock to vacuum and check for leaks as in **10.4**.

10.8 Adjust the helium regulator (diaphragm) valve so that a very slow stream of gas will flow with the needle valve open. Attach the helium supply to the inlet of the bubbler.

10.9 Very cautiously open the bubbler outlet stopcock to equalize pressure and transfer all or most of the fluid in the inlet side arm to the bubbler chamber.

10.10 Close the outlet stopcock and very cautiously open the inlet stopcock to flush remaining fluid from the side arm and fritted disk. Close the inlet stopcock.

10.11 Repeat steps **10.9** and **10.10** several times to obtain more nearly equal pressure on the two sides of the bubbler.

10.12 With the outlet stopcock fully open, cautiously open the inlet stopcock so that the flow of gas produces a froth a few millimetres thick at the surface of bubbler solution. Maintain the flow rate by adjusting the pressure with the regulator valve and continue de-emanation until the pressure in the scintillation

⁷ The sole source of supply of the standard radium solutions known to the committee at this time is the National Institute of Standards and Technology (NIST), 100 Bureau Dr., Stop 3460, Gaithersburg, MD 20899-3460.

⁸ The sole source of supply of the Ascrite II known to the committee at this time is VWR Scientific, 1310 Goshen Parkway, West Chester, PA 19380.