



Designation: ~~D1837–02a (Reapproved 2007)~~ Designation: D1837 – 11

Standard Test Method for Volatility of Liquefied Petroleum (LP) Gases¹

This standard is issued under the fixed designation D1837; the number immediately following the designation indicates the year of original adoption or, in the case of revision, the year of last revision. A number in parentheses indicates the year of last reapproval. A superscript epsilon (ϵ) indicates an editorial change since the last revision or reapproval.

1. Scope*

1.1 This test method is a measure of the relative purity of the various types of liquefied petroleum (LP) gases and helps to ensure suitable volatility performance. The test results, when properly related to vapor pressure and density of the product, can be used to indicate the presence of butane and heavier components in propane type LP-gas, and pentane and heavier components in propane-butane and butane type fuels. The presence of hydrocarbon compounds less volatile than those of which the LP-gas is primarily composed is indicated by an increase in the 95 % evaporated temperature.

1.2 When the type and concentration of higher boiling components is required, chromatographic analysis should be used.

1.3 The values stated in SI units are to be regarded as the standard. The values given in parentheses are for information only.

1.4

1.4 **WARNING**—Mercury has been designated by many regulatory agencies as a hazardous material that can cause central nervous system, kidney and liver damage. Mercury, or its vapor, may be hazardous to health and corrosive to materials. Caution should be taken when handling mercury and mercury containing products. See the applicable product Material Safety Data Sheet (MSDS) for details and EPA's website—<http://www.epa.gov/mercury/faq.htm>—for additional information. Users should be aware that selling mercury and/or mercury containing products into your state or country may be prohibited by law.

1.5 *This standard does not purport to address all of the safety concerns, if any, associated with its use. It is the responsibility of the user of this standard to establish appropriate safety and health practices and determine the applicability of regulatory limitations prior to use.*

2. Referenced Documents

2.1 *ASTM Standards:*²

D96 [Test Methods Method for Water and Sediment in Crude Oil by Centrifuge Method \(Field Procedure\)](#)

D1796 [Test Method for Water and Sediment in Fuel Oils by the Centrifuge Method \(Laboratory Procedure\)](#)

E1 [Specification for ASTM Liquid-in-Glass Thermometers](#)

3. Summary of Test Method

3.1 Refrigerate the sample by means of a cooling coil and collect 100 mL of liquid in a weathering tube. Allow to evaporate (“weather”) at ambient pressure under specified conditions that approximate a single plate distillation. Correct the observed temperature, when 5 mL of liquid test portion remains, for barometric pressure and thermometer ice point error, and report as the 95 % evaporation temperature.

4. Significance and Use

4.1 Volatility, expressed in terms of the 95 % evaporated temperature of the product, is a measure of the amount of least volatile components present in the product. Coupled with a vapor pressure limit, it serves to ensure essentially single-component products in the cases of commercial grades of propane and butane. When volatility is coupled with a vapor pressure limit which has been related to density, as in the case of the commercial PB-mixture, the combination serves to assure essentially two component mixtures for such fuels. When coupled with a proper vapor pressure limit, this measurement serves to assure that special-duty propane products will be composed chiefly of propane and propylene and that propane will be the major constituent.

5. Apparatus

5.1 *Weathering Tube*—A centrifuge tube, cone-shaped, conforming to the dimensions given in Fig. 1 and made of thoroughly

¹ This test method is under the jurisdiction of ASTM Committee D02 on Petroleum Products and Lubricants and is the direct responsibility of Subcommittee D02.H0 on Liquefied Petroleum Gas.

Current edition approved ~~May~~ Oct. 1, 2007-2011. Published ~~June~~ 2007-November 2011. Originally approved in 1961. Last previous edition approved in ~~2002~~ 2007 as D1837–02a(2007). DOI: ~~10.1520/D1837-02AR07.10.1520/D1837-11.~~

² For referenced ASTM standards, visit the ASTM website, www.astm.org, or contact ASTM Customer Service at service@astm.org. For *Annual Book of ASTM Standards* volume information, refer to the standard's Document Summary page on the ASTM website.

*A Summary of Changes section appears at the end of this standard.

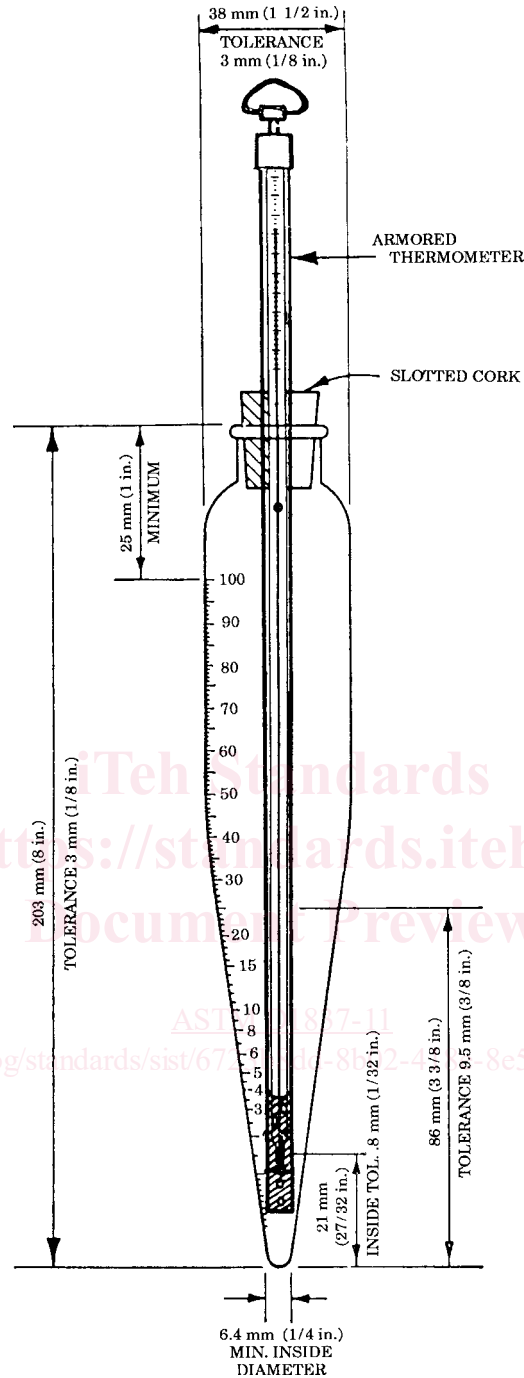

NOTE—For graduation tolerances see Table 1.

FIG. 1 Weathering Tube

annealed heat-resistant glass.³ The shape of the lower tip of the tube is especially important. The taper shall be uniform and the bottom shall be rounded as shown in Fig. 1. The tubes shall comply in wall thickness to ASTM centrifuge tube requirements (Note 1). The graduation tolerances are given in Table 1.

NOTE 1—Requirements for centrifuge tubes appear in Test Methods D96 and D1796.

5.2 *Tube Support*—Means shall be provided for supporting the weathering tube by its neck in a vertical position.

³ Withdrawn.

³ Borosilicate glass has been found satisfactory for this purpose.