INTERNATIONAL STANDARD



2852

INTERNATIONAL ORGANIZATION FOR STANDARDIZATION • МЕЖДУНАРОДНАЯ ОРГАНИЗАЦИЯ ПО СТАНДАРТИЗАЦИИ • ORGANISATION INTERNATIONALE DE NORMALISATION

Metal pipes and fittings — Stainless steel clamp liners with gaskets for the food industry

Tuyauteries et raccords métalliques — Abouts à flancs coniques en acier inoxydable et joints d'étanchéité pour l'industrie alimentaire

First edition — 1974-06-15

ITeH STANDARD PREVIEW
(standards.iteh.ai)

[ISO 2852:1974](https://standards.iteh.ai/catalog/standards/sist/7025ae46-1060-474d-bc29-2c12d4cb7b51/iso-2852-1974)

<https://standards.iteh.ai/catalog/standards/sist/7025ae46-1060-474d-bc29-2c12d4cb7b51/iso-2852-1974>

UDC 621.643

Ref. No. ISO 2852-1974 (E)

Descriptors : food industry, metal pipe, pipe fittings, seals, specifications.

Price based on 10 pages

FOREWORD

ISO (the International Organization for Standardization) is a worldwide federation of national standards institutes (ISO Member Bodies). The work of developing International Standards is carried out through ISO Technical Committees. Every Member Body interested in a subject for which a Technical Committee has been set up has the right to be represented on that Committee. International organizations, governmental and non-governmental, in liaison with ISO, also take part in the work.

Draft International Standards adopted by the Technical Committees are circulated to the Member Bodies for approval before their acceptance as International Standards by the ISO Council.

International Standard ISO 2852 was drawn up by Technical Committee ISO/TC 5, *Metal pipes and fittings*, and circulated to the Member Bodies in September 1972.

It has been approved by the Member Bodies of the following countries :

Austria
Canada
Czechoslovakia
Denmark
Egypt, Arab Rep. of
Finland
France

Hungary
India
Israel
Italy
Mexico
Norway
Romania

ISO 2852:1974

Spain

Sweden

Switzerland

Thailand

Turkey

United Kingdom

The Member Body of the following country expressed disapproval of the document on technical grounds :

Germany

Metal pipes and fittings — Stainless steel clamp liners with gaskets for the food industry

1 SCOPE

This International Standard specifies the dimensions, tolerances, surface roughness, materials, assembling, and hygienic requirements for welded and expanded type clamp liners and gaskets in pipe couplings for the food industry.

2 FIELD OF APPLICATION

Clamp liners in pipe couplings for the food industry are intended to be used with stainless steel tubes specified in ISO/R 2037.

3 REFERENCES

ISO/R 48, *Determination of hardness of vulcanized rubbers.*

ISO/R 79, *Brinell hardness test for steel.*

ISO/R 80, *Rockwell hardness test (B and C scales) for steel.*

ISO/R 81, *Vickers hardness test for steel (Load 5 to 100 kgf).*

ISO/R 468, *Surface roughness.*

ISO/R 2037, *Pipes and fittings — Stainless steel tubes for the food industry.*

4 DEFINITIONS

4.1 clamp pipe coupling: Coupling with two liners intended for joining pipe ends together by means of a clamp.

4.2 clamp liner: Flanged pipe coupling part, with one conical face to provide means for connecting mating liners.

4.2.1 welded type clamp liner: Clamp liner to be joined to a pipe end by a butt-weld.

4.2.2 expanded type clamp liner: Clamp liner to be attached to a pipe end by expanding.

4.3 gasket: Ring-shaped pipe coupling part intended to make a hygienic liquid-tight joint between the flanges of two clamp liners.

5 SYMBOLS

C_1 = outside neck diameter of expanded type liner

C_2 = groove diameter and gasket bulge diameter

C_4 = inside diameter of gasket

C_5 = inside diameter of expanded type liner

C_6 = inside diameter of welded type liner

C_7 = flange diameter

C_{10} = outside neck diameter of welded type liner

E = inside diameter of gasket lip

F_2 = total length of welded type liner

F_3 = total length of expanded type liner

K = groove depth

L_1 = flange thickness

P_1 = flange edge radius

P_2 = groove edge radius

R_2 = flange fillet radius

R_3 = groove bottom radius

R_4 = gasket fillet radius

R_5 = gasket bulge radius

S = outside diameter of gasket (without lip)

T_1 = gasket web thickness

T_2 = gasket lip length

T_4 = gasket lip thickness

U = gasket bulge thickness

U_1 = lock ring groove diameter

U_2 = lock ring outside diameter

V = gasket compression thickness

Y = radial clearance between clamp and flange

Z = radial clearance between clamp and neck of expanded type liner

α = flange angle

β = groove angle

6 EXPANDED TYPE CLAMP LINER

6.1 Dimensions

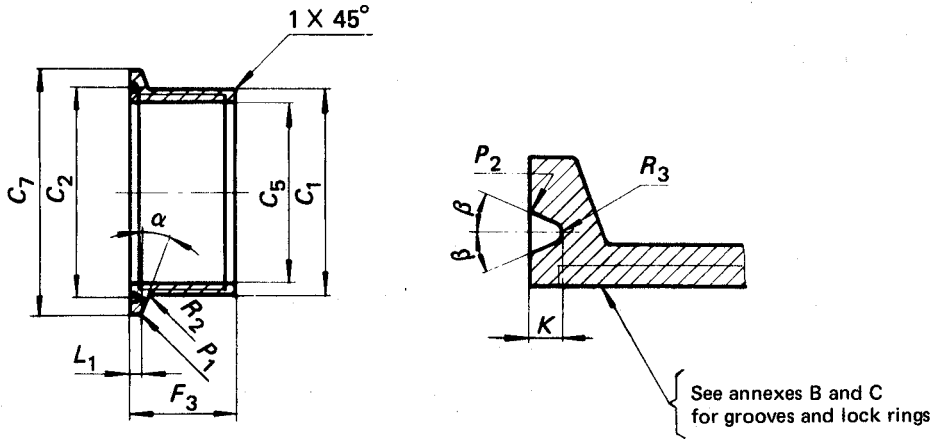

- $L_1 = 2,85 \text{ mm (0.112 in)}$
- $K = 1,6 \text{ mm (0.063 in)}$
- $P_1 = 0,8 \text{ mm (0.031 in)}$
- $P_2 = 0,8 \text{ mm (0.031 in)}$
- $R_2 = 2 \text{ mm (0.079 in)}$
- $R_3 = 1,2 \text{ mm (0.047 in)}$
- $\alpha = 20^\circ$
- $\beta = 23^\circ$

iTeh STANDARD PREVIEW

Nominal size		C_5		C_1		C_7		C_2		F_3	
mm	in	mm	in	mm	in	mm	in	mm	in	mm	in
12	—	12	0.472	16	0.630	34	1.339	27,5	1.083	16	0.630
18	—	18	0.709	22	0.866	34	1.339	27,5	1.083	18	0.709
22	—	22	0.866	26	1.024	34	1.339	27,5	1.083	20	0.787
25	—	25	0.984	29	1.142	50,5	1.988	43,5	1.713	20	0.787
28	—	28	1.102	32	1.260	50,5	1.988	43,5	1.713	20	0.787
33,7	1.327	33,7	1.327	38,1	1.500	50,5	1.988	43,5	1.713	20	0.787
38	1.500	38	1.496	42,4	1.669	50,5	1.988	43,5	1.713	20	0.787
40	—	40	1.575	44,8	1.764	64	2.520	56,5	2.224	20	0.787
51	2.000	51	2.008	55,8	2.197	64	2.520	56,5	2.224	25	0.984
63,5	2.500	63,5	2.500	68,9	2.713	77,5	3.051	70,5	2.776	30	1.181
70	2.750	70	2.756	75,8	2.984	91	3.583	83,5	3.287	30	1.181
76,1	3.000	76,1	2.996	81,9	3.224	91	3.583	83,5	3.287	30	1.181

6.2 Tolerances

Inside neck diameter, C_5 : A10

Flange thickness, L_1 : j_s12

Flange diameter, C_7 : h11

Groove diameter, C_2 : N11

Groove depth, K : J_s13

Outside neck diameter, C_1 : j_s10

7 WELDED TYPE CLAMP LINER

7.1 Dimensions

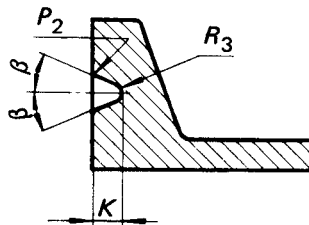
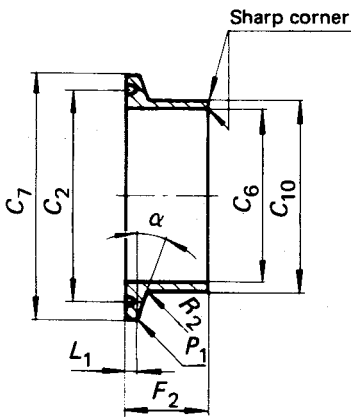

- $K = 1,6 \text{ mm (0.064 in)}$
- $P_1 = 0,8 \text{ mm (0.031 in)}$
- $P_2 = 0,8 \text{ mm (0.031 in)}$
- $R_2 = 2 \text{ mm (0.079 in)}$
- $R_3 = 1,2 \text{ mm (0.047 in)}$
- $\alpha = 20^\circ$
- $\beta = 23^\circ$

iTeh STANDARD PREVIEW
(standards.iteh.ai)

Nominal size		C_6		C_{10}		C_7		F_2		C_2		L_1	
mm	in	mm	in	mm	in	mm	in	mm	in	mm	in	mm	in
25	—	22,6	0.890	25,6	1.008	50,5	1.988	21,5	0.846	43,5	1.713	2,85	0.112
28	—	25,6	1.008	28,6	1.126	50,5	1.988	21,5	0.846	43,5	1.713	2,85	0.112
33,7	1.327	31,3	1.232	34,3	1.350	50,5	1.988	21,5	0.846	43,5	1.713	2,85	0.112
38	1.500	35,6	1.402	38,6	1.520	50,5	1.988	21,5	0.846	43,5	1.713	2,85	0.112
40	—	37,6	1.480	40,6	1.598	64	2.520	21,5	0.846	56,5	2.224	2,85	0.112
51	2.000	48,6	1.913	51,6	2.031	64	2.520	21,5	0.846	56,5	2.224	2,85	0.112
63,5	2.500	60,3	2.374	64,1	2.524	77,5	3.051	28	1.102	70,5	2.776	2,85	0.112
70	2.750	66,8	2.630	70,6	2.780	91	3.583	28	1.102	83,5	3.287	2,85	0.112
76,1	3.000	72,9	2.870	76,7	3.020	91	3.583	28	1.102	83,5	3.287	2,85	0.112
88,9	3.500	84,9	3.342	89,8	3.535	106	4.173	28	1.102	97	3.819	2,85	0.112
101,6	4.000	97,6	3.842	102,5	4.035	119	4.685	28	1.102	110	4.331	2,85	0.112
114,3	4.500	110,3	4.342	115,6	4.555	130	5.118	28	1.102	122	4.803	2,85	0.112
139,7	5.500	135,7	5.342	141,2	5.559	155	6.102	28	1.102	146	5.748	5,6	0.220
168,3	6.625	163,1	6.421	170	6.693	183	7.205	28	1.102	174	6.850	5,6	0.220
219,1	8.625	213,9	8.421	221,2	8.709	233,5	9.193	28	1.102	225	8.858	5,6	0.220

7.2 Tolerances

Inside neck diameter, C_6 : N11

Flange thickness, L_1 : j_s12

Flange diameter, C_7 : h11

Groove diameter, C_2 : N11

Groove depth, K : J_s13

Outside neck diameter, C_{10} : h11

8 GASKET

8.1 Dimensions

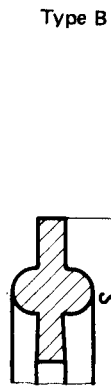
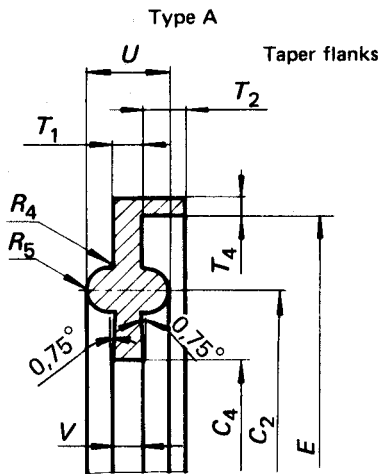

- $T_4 = 1,1 \text{ mm (0.043 in)}$
- $U = 5,5 \text{ mm (0.216 in)}$
- $T_1 = 1,7 \text{ mm (0.067 in)}$
- $R_4 = 0,4 \text{ mm (0.016 in)}$
- $R_5 = 1,2 \text{ mm (0.047 in)}$
- $V = 2,1 \text{ mm (0.083 in)}$
- $T_2 = 2,8 \text{ mm (0.110 in)}$

Gasket type A is intended for use when the pipe ends are frequently disconnected.

Nominal size		C_4		C_2		E and S	
mm	in	mm	in	mm	in	mm	in
12	—	10,2	0.402	27,5	1.083	34	1.339
18	—	16,2	0.638	27,5	1.083	34	1.339
22	—	20,2	0.795	27,5	1.083	34	1.339
25	—	22,8	0.898	43,5	1.713	50,5	1.988
28	—	25,8	1.016	43,5	1.713	50,5	1.988
33,7	1.327	31,5	1.240	43,5	1.713	50,5	1.988
38	1.500	35,8	1.398	43,5	1.713	50,5	1.988
40	—	37,8	1.488	56,5	2.224	64	2.520
51	2.000	48,8	1.921	56,5	2.224	64	2.520
63,5	2.500	60,5	2.382	70,5	2.776	77,5	3.051
70	2.750	67	2.638	83,5	3.287	91	3.583
76,1	3.000	73,1	2.878	83,5	3.287	91	3.583
88,9	3.500	85,1	3.350	97	3.819	106	4.173
101,6	4.000	97,8	3.850	110	4.331	119	4.685
114,3	4.500	110,5	4.350	122	4.803	130	5.118
139,7	5.500	135,9	5.350	146	5.748	155	6.102
168,3	6.625	163,3	6.429	174	6.850	183	7.204
219,1	8.625	214,1	8.429	225	8.858	233,5	9.193

8.2 Tolerances

Inside diameter of lip, $E : -0,5^0 \text{ mm}$

Outside diameter, $S : \pm 0,5 \text{ mm}$

Bulge diameter, $C_2 : -0,5^0 \text{ mm}$

Inside diameter, $C_4 : +0,5^0 \text{ mm}$

Lip thickness, $T_4 : \pm 0,2 \text{ mm}$

Bulge thickness, $U : \pm 0,2 \text{ mm}$

Web thickness, $T_1 : +0,25^0 \text{ mm}$

Gasket compression thickness, $V : +0,25^0 \text{ mm}$

Lip length, $T_2 : \pm 0,3 \text{ mm}$.

9 ASSEMBLING

9.1 Welding

Welded type clamp liners shall be attached to the pipe ends by butt welding.

9.2 Expansion

Expanded type clamp liners shall be attached to the pipe ends by expanding. A method for carrying out the expansion is described in annex D. This method can be applied to sizes up to and including 76,1 mm (3.000 in).

10 HYGIENIC REQUIREMENTS

10.1 All surfaces of the coupling in contact with the product shall be easily accessible for cleaning, either by cleaning in place (CIP) methods or by manual cleaning when disassembled. Removable parts shall be readily demountable.

10.2 Welded liners shall be internally clean and smooth. They shall be free from harmful surface defects or inclusions.

10.3 The gasket shall be of a material compatible under processing conditions with the material of the fitting, with the foodstuffs and with the cleaning fluids utilized. It shall not, for example, impart an odour or taste to the foodstuff.

11 SURFACE ROUGHNESS

Surface roughness of expanded and welded type clamp liners shall be specified in accordance with ISO/R 468. For finely finished surfaces, $R_a \leq 1,0 \mu\text{m}$ (40 μin).

12 MATERIALS

12.1 Clamp liners

Austenitic stainless steel shall be selected from ISO¹⁾

Suitable materials for general applications are the steel types TS 47, TS 60 and TS 61.

12.2 Gaskets

The gaskets shall be of natural or synthetic rubber with a hardness corresponding to 75 to 85 IRHD according to ISO/R 48. The material shall meet the hygienic requirements and have a reasonable life expectancy.

iteh STANDARD PREVIEW
(standards.iteh.ai)

[ISO 2852:1974](https://standards.iteh.ai/catalog/standards/sist/7025ae46-1060-474d-bc29-2c12d4cb7b51/iso-2852-1974)

<https://standards.iteh.ai/catalog/standards/sist/7025ae46-1060-474d-bc29-2c12d4cb7b51/iso-2852-1974>

1) In preparation.

ANNEX A

CROSS-SECTION OF CLAMP COUPLING ASSEMBLY

This annex specifies the inside contour of the clamp profile to suit the mating flanges on liners.

A.1 DEFINITION AND SYMBOLS

clamp : Ring-shaped pipe coupling part with taper sided channel section.

Y = radial clearance between clamp and flange

Z = radial clearance between clamp and neck of expanded type liner

A.2 DIMENSIONS

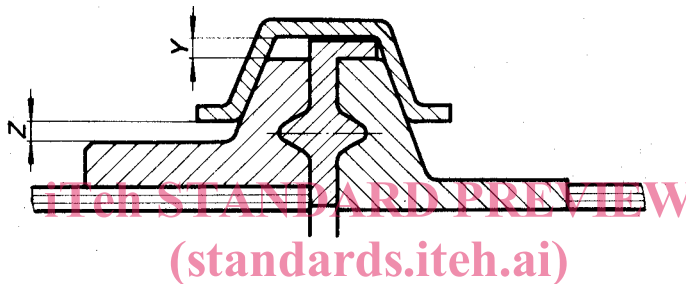

ISO 2852:1974

<https://standards.iteh.ai/catalog/standards/sist/7025ae46-1060-474d-bc29-2c12d4cb7b51/iso-2852-1974>

$Y = 1,6 \text{ mm (0.063 in) min.}$

$Z = 1,6 \text{ mm (0.063 in) min. for sizes } \geq 38 \text{ mm}$

ANNEX B

GROOVES FOR EXPANDED TYPE CLAMP LINERS

Expanded type clamp liners shall be provided internally with some form of groove to give adequate strength to the joint between liner and pipe end. The following figures show a satisfactory grooving.

This annex is applicable to sizes 25 mm up to and including 76,1 mm only. The use of the lock ring is optional for expanded type liners.

B.1 SYMBOL

U_1 = lock ring groove diameter

B.2 DIMENSIONS

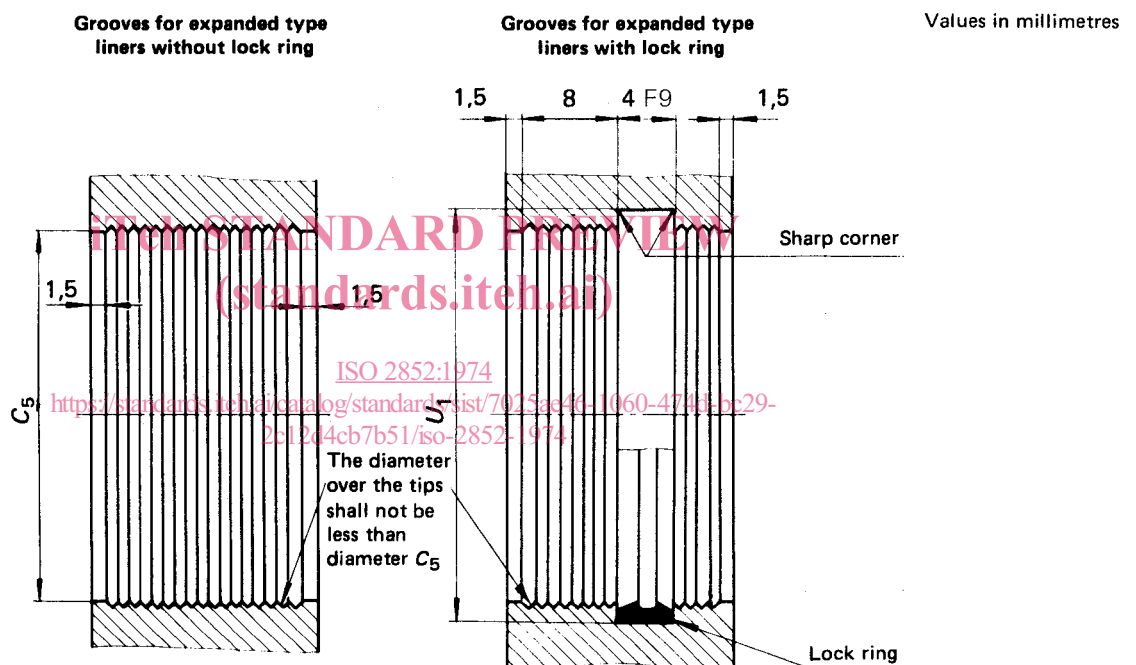

Nominal size		Lock ring groove diameter U_1	
mm	in	mm	in
25	—	27,25	1.073
28	—	30,25	1.191
33,7	1.327	35,95	1.415
38	1.500	40,25	1.585
40	—	42,25	1.663
51	2.000	53,25	2.096
63,5	2.500	65,65	2.585
70	2.750	72,15	2.841
76,1	3.000	78,25	3.081

B.3 TOLERANCES

On the lock ring groove diameter, U_1 : h12