

INTERNATIONAL  
STANDARD

**ISO**  
**2852**

Second edition  
1993-06-15

---

---

**Stainless steel clamp pipe couplings for the  
food industry**

**iTeh STANDARD PREVIEW**  
*Raccords rapides en acier inoxydable pour l'industrie alimentaire*  
**(standards.iteh.ai)**

ISO 2852:1993

<https://standards.iteh.ai/catalog/standards/sist/f42fc6ae-da24-450b-bef8-c5f71a31826b/iso-2852-1993>



Reference number  
ISO 2852:1993(E)

## Contents

	Page
1 Scope .....	1
2 Normative references .....	1
3 Definitions .....	1
4 Symbols .....	1
5 Dimensions and tolerances .....	2
5.1 Expanded-type clamp liner .....	2
5.2 Welded-type clamp liner .....	2
5.3 Gasket .....	2
6 Assembling .....	2
6.1 Welding .....	2
6.2 Expansion .....	2
7 Hygienic requirements .....	2
8 Surface roughness .....	2
9 Materials .....	2
9.1 Clamp liners .....	2
9.2 Gaskets .....	2
<b>Annexes</b>	
A Cross-section of clamp pipe coupling assembly .....	6
B Grooving for expanded-type clamp liners .....	7
C Lock rings for expanded-type clamp liners .....	9
D Method of expansion with straight pipe .....	10
E Bibliography .....	12

iTeh STANDARD PREVIEW  
(standards.iteh.ai)

<https://standards.iteh.ai/catalog/standards/sist/f42fc6ae-da24-450b-bef8-c5171a31820b/iso-2852-1993>

© ISO 1993

All rights reserved. No part of this publication may be reproduced or utilized in any form or by any means, electronic or mechanical, including photocopying and microfilm, without permission in writing from the publisher.

International Organization for Standardization  
Case Postale 56 • CH-1211 Genève 20 • Switzerland

Printed in Switzerland

## Foreword

ISO (the International Organization for Standardization) is a worldwide federation of national standards bodies (ISO member bodies). The work of preparing International Standards is normally carried out through ISO technical committees. Each member body interested in a subject for which a technical committee has been established has the right to be represented on that committee. International organizations, governmental and non-governmental, in liaison with ISO, also take part in the work. ISO collaborates closely with the International Electrotechnical Commission (IEC) on all matters of electrotechnical standardization.

Draft International Standards adopted by the technical committees are circulated to the member bodies for voting. Publication as an International Standard requires approval by at least 75 % of the member bodies casting a vote.

International Standard ISO 2852 was prepared by Technical Committee ISO/TC 5, *Ferrous metal pipes and metallic fittings*, Sub-Committee SC 1, *Steel tubes*.

This second edition cancels and replaces the first edition (ISO 2852:1974), the requirements of which for expanded-type clamp liners, welded-type clamp liners, gaskets and materials for clamp liners have been technically revised.

Annexes A, B and C form an integral part of this International Standard. Annexes D and E are for information only.

**iTeh STANDARD PREVIEW**  
This page intentionally left blank  
**(standards.iteh.ai)**

ISO 2852:1993

<https://standards.iteh.ai/catalog/standards/sist/f42fc6ae-da24-450b-bef8-c5f71a31826b/iso-2852-1993>

# Stainless steel clamp pipe couplings for the food industry

## 1 Scope

This International Standard specifies the dimensions, tolerances, surface roughness, materials, assembling, and hygienic requirements for welded- and expanded-type clamp liners and gaskets in clamp pipe couplings for the food industry. The clamps are not standardized but suitable clearances are specified in annex A.

Clamp liners in clamp couplings for the food industry are intended to be used with stainless steel tubes specified in ISO 2037.

## 2 Normative references

The following standards contain provisions which, through reference in this text, constitute provisions of this International Standard. At the time of publication, the editions indicated were valid. All standards are subject to revision, and parties to agreements based on this International Standard are encouraged to investigate the possibility of applying the most recent editions of the standards indicated below. Members of IEC and ISO maintain registers of currently valid International Standards.

ISO 48:1979, *Vulcanized rubbers — Determination of hardness (Hardness between 30 and 85 IRHD)*.

ISO 286-2:1988, *ISO system of limits and fits — Part 2: Tables of standard tolerance grades and limit deviations for holes and shafts*.

ISO 2037:1992, *Stainless steel tubes for the food industry*.

ISO 2604-1:1975, *Steel products for pressure purposes — Quality requirements — Part 1: Forgings*.

ISO 6506:1981, *Metallic materials — Hardness test — Brinell test*.

ISO 6507-1:1982, *Metallic materials — Hardness test — Vickers test — Part 1: HV 5 to HV 100*.

ISO 6508:1986, *Metallic materials — Hardness test — Rockwell test (scales A - B - C - D - E - F - G - H - K)*.

## 3 Definitions

For the purposes of this International Standard, the following definitions apply.

**3.1 clamp pipe coupling:** Coupling with two liners intended for joining pipe ends together by means of a clamp.

**3.2 clamp liner:** Flanged pipe coupling part, with one conical face to provide means for connecting mating liners.

**3.2.1 welded-type clamp liner:** Clamp liner intended to be joined to a pipe end by butt welding.

**3.2.2 expanded-type clamp liner:** Clamp liner intended to be attached to a pipe end by expansion.

**3.3 gasket:** Ring-shaped pipe coupling part intended to make a hygienic liquid-tight joint between the flanges of two clamp liners.

**3.4 clamp:** Ring-shaped pipe coupling part with a taper-sided channel section.

## 4 Symbols

$C_1$	outside neck diameter of expanded-type liner
$C_2$	groove diameter and gasket bulge diameter
$C_4$	inside diameter of gasket
$C_5$	inside diameter of expanded-type liner
$C_6$	inside diameter of welded-type liner
$C_7$	flange diameter
$C_{10}$	outside neck diameter of welded-type liner

$E$	inside diameter of gasket lip
$F_2$	total length of welded-type liner
$F_3$	total length of expanded-type liner
$K$	groove depth
$L_1$	flange thickness
$P_1$	flange edge radius
$P_2$	groove edge radius
$R_2$	flange fillet radius
$R_3$	groove bottom radius
$R_4$	gasket fillet radius
$R_5$	gasket bulge radius
$S$	outside diameter of gasket (without lip)
$T_1$	gasket web thickness
$T_2$	gasket lip length
$T_4$	gasket lip thickness
$U$	gasket bulge thickness
$U_1$	lock ring groove diameter
$U_2$	lock ring outside diameter
$V$	gasket compression thickness
$Y$	radial clearance between clamp and flange
$Z$	radial clearance between clamp and neck of expanded-type liner
$\alpha$	flange angle
$\beta$	groove angle

## 5 Dimensions and tolerances

### 5.1 Expanded-type clamp liner

The dimensions, in millimetres, and the tolerance classes (see ISO 286-2) are given in figure 1 and table 1.

### 5.2 Welded-type clamp liner

The dimensions, in millimetres, and the tolerance classes (see ISO 286-2) are given in figure 2 and table 2.

### 5.3 Gasket

The dimensions and tolerances, in millimetres, are given in figure 3 and table 3.

## 6 Assembling

### 6.1 Welding

Welded-type clamp liners shall be attached to the pipe ends by butt welding.

### 6.2 Expansion

Expanded-type clamp liners shall be attached to the pipe ends by expanding. A method for carrying out the expansion is described in annex D. This method can be applied to nominal sizes up to and including 76,1 mm.

## 7 Hygienic requirements

**7.1** All surfaces of the coupling in contact with the foodstuff shall be easily accessible for cleaning, either by cleaning in place methods or by manual cleaning when disassembled. Removable parts shall be readily demountable.

**7.2** The interior surface of welded-type liners shall be clean and smooth. It shall be free from surface defects and inclusions.

**7.3** The gasket shall be made of a material compatible under processing conditions with the material of the fitting, with the foodstuffs and with the cleaning fluids utilized. It shall not, for example, impart an odour or taste to the foodstuff.

## 8 Surface roughness

The surface roughness of expanded- and welded-type clamp liners, in accordance with the specifications of ISO 468, shall be, for finely finished surfaces,  $R_a \leq 1 \mu\text{m}$ .

## 9 Materials

### 9.1 Clamp liners

Austenitic stainless steel shall be selected from ISO 2604-1.

Generally the steel types F47 and F62 are suitable (similar to the types recommended for tubes in ISO 2037).

### 9.2 Gaskets

The gaskets shall be of natural or synthetic rubber with a hardness corresponding to 75 IRHD to 85 IRHD in accordance with ISO 48. The material shall meet the hygienic requirements and have a reasonable life expectancy.

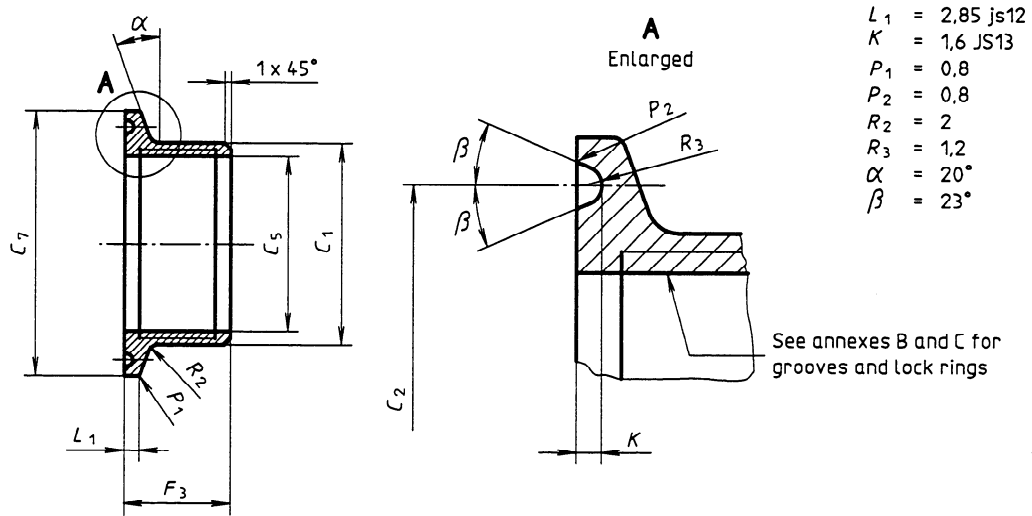

Figure 1

iTech STANDARD PREVIEW  
 Table 1  
 (standards.itih.ai)

Nominal size	$C_5$ A10	$C_1$ js10	$C_7$ h11	$C_2$ N11	$F_3$
12	12	16	34	27,5	16
12,7	12,7	16,7	34	27,5	16
17,2	17,2	21,2	34	27,5	18
21,3	21,3	25,3	34	27,5	20
25	25	29	50,5	43,5	20
33,7	33,7	38,1	50,5	43,5	20
38	38	42,4	50,5	43,5	20
40	40	44,8	64	56,5	20
51	51	55,8	64	56,5	25
63,5	63,5	68,9	77,5	70,5	30
70	70	75,8	91	83,5	30
76,1	76,1	81,9	91	83,5	30

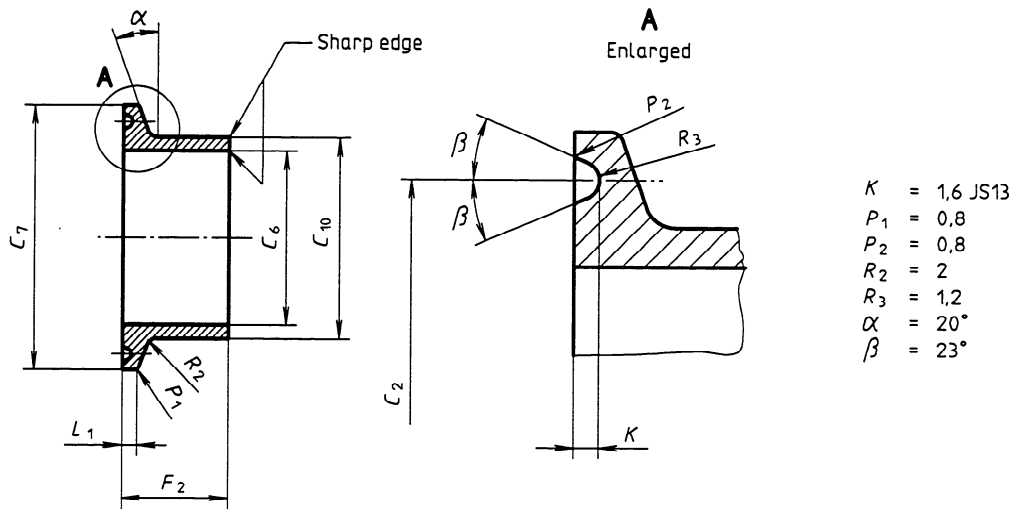
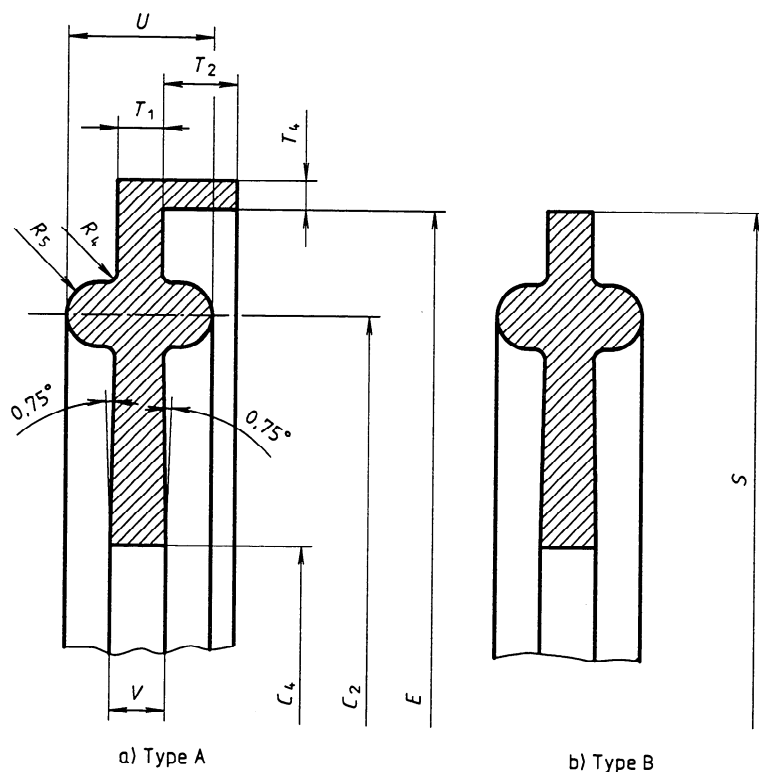

Figure 2

Table 2

Nominal size	$C_6$ N11	$C_{10}$ h11	$C_7$ h11	$F_2$	$C_2$ N11	$L_1$ js12
<b>25</b>	22,6	25,6	50,5	21,5	43,5	2,85
<b>33,7</b>	31,3	34,3	50,5	21,5	43,5	2,85
<b>38</b>	35,6	38,6	50,5	21,5	43,5	2,85
<b>40</b>	37,6	40,6	64	21,5	56,5	2,85
<b>51</b>	48,6	51,6	64	21,5	56,5	2,85
<b>63,5</b>	60,3	64,1	77,5	21,5	70,5	2,85
<b>70</b>	66,8	70,6	91	21,5	83,5	2,85
<b>76,1</b>	72,9	76,7	91	21,5	83,5	2,85
<b>88,9</b>	84,9	89,8	106	21,5	97	2,85
<b>101,6</b>	97,6	102,5	119	21,5	110	2,85
<b>114,3</b>	110,3	115,6	130	28	122	2,85
<b>139,7</b>	135,7	141,2	155	28	146	5,6
<b>168,3</b>	163,1	170	183	28	174	5,6
<b>219,1</b>	213,9	221,2	233,5	28	225	5,6





**iTeh STANDARD PREVIEW**  
**Figure 3**  
**(standards.iteh.ai)**

ISO 2852:1993

<https://standards.iteh.ai/catalog/standards/sist/f42fc6ae-da24-450b-bef8-c571a31826b/iso-2852-1993> **Table 3**

Nominal size	$C_4$	$C_2$	$E$	$S$
	$\begin{matrix} +0,5 \\ 0 \end{matrix}$	$\begin{matrix} 0 \\ -0,5 \end{matrix}$	$\begin{matrix} 0 \\ -0,5 \end{matrix}$	$\pm 0,5$
<b>12</b>	10,2	27,5		34
<b>12,7</b>	10,9	27,5		34
<b>17,2</b>	15,4	27,5		34
<b>21,3</b>	19,5	27,5		34
<b>25</b>	22,8	43,5		50,5
<b>33,7</b>	31,5	43,5		50,5
<b>38</b>	35,8	43,5		50,5
<b>40</b>	37,8	56,5		64
<b>51</b>	48,8	56,5		64
<b>63,5</b>	60,5	70,5		77,5
<b>70</b>	67	83,5		91
<b>76,1</b>	73,1	83,5		91
<b>88,9</b>	85,1	97		106
<b>101,6</b>	97,8	110		119
<b>114,3</b>	110,5	122		130
<b>139,7</b>	135,9	146		155
<b>168,3</b>	163,3	174		183
<b>219,1</b>	214,1	225		233,5

## Annex A (normative)

### Cross-section of clamp pipe coupling assembly

#### A.1 Scope

This annex specifies the inside contour of the clamp profile to suit the mating flanges on liners.

#### A.2 Clearances

See figure A.1.

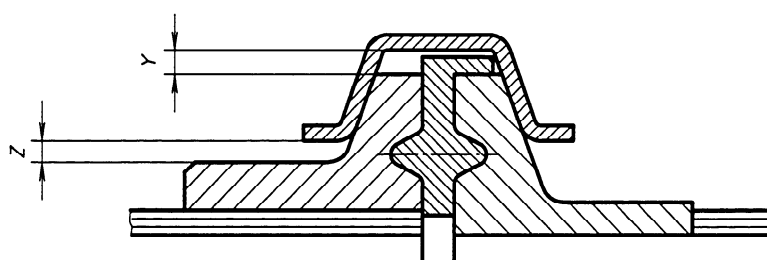

Y = 1,6 mm min.

Z = 1,6 mm min. for nominal sizes  $\geq 38$  mm

iTeh STANDARD PREVIEW  
(standards.iteh.ai)

Figure A.1  
ISO 2852:1993

<https://standards.iteh.ai/catalog/standards/sist/f42fc6ae-da24-450b-bef8-c5f71a31826b/iso-2852-1993>

## Annex B (normative)

### Grooving for expanded-type clamp liners

#### B.1 Scope

This annex is applicable to nominal sizes 25 mm up to and including 76,1 mm only. The use of the lock ring is optional for expanded-type liners.

#### B.2 Design

Expanded-type clamp liners shall be provided internally with some form of grooving to give ade-

quate strength to the joint between liner and pipe end. Figures B.1 and B.2 show the positioning of the grooves.

#### B.3 Dimensions

The dimensions, in millimetres, and the tolerance classes (see ISO 286-2) are given in figures B.1 and B.2 and table B.1.

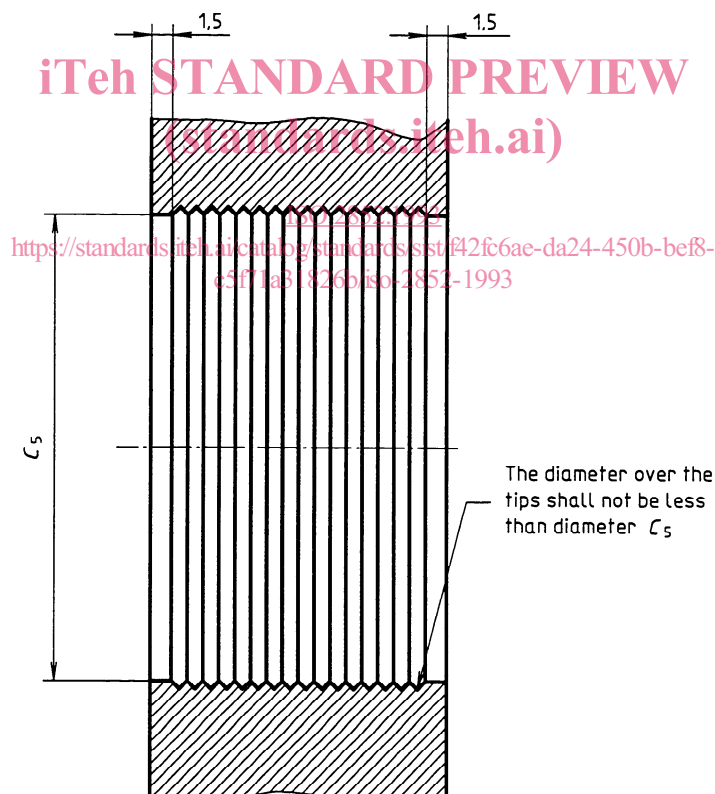

Figure B.1 — Grooving for expanded-type liners without lock ring