



Designation: D6728 – 11

# Standard Test Method for Determination of Contaminants in Gas Turbine and Diesel Engine Fuel by Rotating Disc Electrode Atomic Emission Spectrometry<sup>1</sup>

This standard is issued under the fixed designation D6728; the number immediately following the designation indicates the year of original adoption or, in the case of revision, the year of last revision. A number in parentheses indicates the year of last reapproval. A superscript epsilon ( $\epsilon$ ) indicates an editorial change since the last revision or reapproval.

## 1. Scope\*

1.1 This test method covers the determination of contaminants and materials as a result of corrosion in gas turbine or diesel engine fuels by rotating disc electrode atomic emission spectroscopy (RDE-AES).

1.1.1 The test method is applicable to ASTM Grades 0-GT, 1-GT, 2-GT, 3-GT, and 4-GT gas turbine fuels and Grades Low Sulfur No. 1-D, Low Sulfur No. 2-D, No. 1-D, No. 2-D, and No. 4-D diesel fuel oils.

1.1.2 This test method provides a rapid at-site determination of contamination and corrosive elements ranging from fractions of mg/kg to hundreds of mg/kg in gas turbine and diesel engine fuels so the fuel quality and level of required treatment can be determined.

1.1.3 This test method uses oil-soluble metals for calibration and does not purport to quantitatively determine or detect insoluble particles.

1.2 The values stated in SI units are to be regarded as standard. No other units of measurement are included in this standard. The preferred units are mg/kg (ppm by mass).

1.3 *This standard does not purport to address all of the safety concerns, if any, associated with its use. It is the responsibility of the user of this standard to establish appropriate safety and health practices and determine the applicability of regulatory limitations prior to use.*

## 2. Referenced Documents

### 2.1 ASTM Standards:<sup>2</sup>

[D975 Specification for Diesel Fuel Oils](#)

[D2880 Specification for Gas Turbine Fuel Oils](#)

[D4057 Practice for Manual Sampling of Petroleum and Petroleum Products](#)

[D5854 Practice for Mixing and Handling of Liquid Samples of Petroleum and Petroleum Products](#)

[D6299 Practice for Applying Statistical Quality Assurance and Control Charting Techniques to Evaluate Analytical Measurement System Performance](#)

## 3. Terminology

### 3.1 Definitions:

3.1.1 *burn, vt*—in emission spectroscopy, to vaporize and excite a specimen with sufficient energy to generate spectral radiation.

3.1.2 *calibration, n*—the determination of the values of the significant parameters by comparison with values indicated by a set of reference standards.

3.1.3 *calibration curve, n*—the graphical or mathematical representation of a relationship between the assigned (known) values of standards and the measured responses from the measurement system.

3.1.4 *calibration standard, n*—a standard having an accepted value (reference value) for use in calibrating a measurement instrument or system.

3.1.5 *detection limit, n*—the smallest concentration of an element that can be measured for specific analysis conditions and data collection periods.

3.1.6 *emission spectroscopy, n*—measurement of energy spectrum emitted by or from an object under some form of energetic stimulation; for example, light, electrical discharge, and so forth.

### 3.2 Definitions of Terms Specific to This Standard:

3.2.1 *arc discharge, n*—a self-sustaining, high current density, high temperature discharge uniquely characterized by a cathode fall nearly equal to the ionization potential of the gas or vapor in which it exists.

3.2.2 *check sample, n*—a reference material usually prepared by a single laboratory for its own use as a measurement control standard, or for the qualification of a measurement method.

<sup>1</sup> This test method is under the jurisdiction of ASTM Committee D02 on Petroleum Products, Liquid Fuels, and Lubricants and is the direct responsibility of Subcommittee D02.03 on Elemental Analysis.

Current edition approved Oct. 1, 2011. Published November 2011. Originally approved in 2001. Last previous edition approved in 2006 as D6728–01(2006). DOI: 10.1520/D6728-11.

<sup>2</sup> For referenced ASTM standards, visit the ASTM website, www.astm.org, or contact ASTM Customer Service at service@astm.org. For *Annual Book of ASTM Standards* volume information, refer to the standard's Document Summary page on the ASTM website.

\*A Summary of Changes section appears at the end of this standard

3.2.3 *contaminant, n*—material in a fuel sample that may cause ash deposition or high temperature corrosion.

3.2.4 *graphite disc electrode, n*—a soft form of the element carbon manufactured into the shape of a disc for use as an electrode in arc/spark spectrometers for oil and fuel analysis.

3.2.5 *graphite rod electrode, n*—a soft form of the element carbon manufactured into the shape of a rod for use as a counter electrode in arc/spark spectrometers for oil and fuel analysis.

3.2.6 *profiling, n*—to set the actual position of the entrance slit to produce optimum measurement intensity.

3.2.7 *standardization, n*—the process of reestablishing and correcting a calibration curve through the analysis of at least two known oil standards.

3.2.8 *uptake rate, n*—the amount of oil or fuel sample that is physically carried by the rotating disc electrode into the arc for analysis.

#### 4. Summary of Test Method

4.1 A fuel test specimen is excited by a controlled arc discharge using the rotating disk technique. The radiant energies of selected analytical lines and a reference are collected and stored by way of photomultiplier tubes, charge coupled devices, or other suitable detectors. A comparison is made of the emitted intensities of the elements in the fuel test specimen against those measured with calibration standards. The concentration of the elements present in the fuel test specimen are calculated and displayed.

#### 5. Significance and Use

5.1 Operating experience of gas turbines and diesel engines has shown that some of the ash-forming substances present in a fuel can lead to high temperature corrosion, ash deposition, and fuel system fouling. Ash-forming materials may be in a fuel as oil-soluble metallo-organic compounds as water-soluble salts or as solid foreign contamination. Their presence and concentration varies with the geographical source of a crude oil and they are concentrated in the residual fractions during the refining process. Although distillate fuel oils are typically contaminant free, ash-forming materials may be introduced later in the form of salt-bearing water or by contact with other petroleum products during transportation and storage. Specifications of gas turbine and diesel engine fuels and the significance of contamination and trace metals are detailed in Specifications **D2880** and **D975**.

5.1.1 Pre-conditioning of the fuel before it reaches the gas turbine or diesel engine has become a prerequisite for installations that use heavy petroleum fuel, and also for sites that use light distillate fuel oils. On-site fuel analysis to determine the extent of contamination is an integral part of a fuel quality management program. It is used first to determine the extent of the required treatment, and later, the effectiveness of the treatment. It starts with the delivery of the fuel, continues throughout fuel handling and ends only as the fuel is injected into the turbine or engine.

5.1.2 Fuel contamination specifications vary among the different gas turbine manufacturers. However, without

**TABLE 1 Elements and Recommended Wavelengths**

Element	Wavelength, nm	Element	Wavelength, nm
Aluminum	308.21	Magnesium	280.20, 518.36
Calcium	393.37	Nickel	341.48
Chromium	425.43	Potassium	766.49
Copper	324.75	Silicon	251.60
Iron	259.94	Sodium	588.99
Lead	283.31	Vanadium	290.88, 437.92
Lithium	670.78	Zinc	213.86
Manganese	403.07		

exception, each requires that contaminants must be as low as possible. In most power generation installations, it is the owner who has the responsibility of verifying fuel cleanliness in compliance with the turbine manufacturer's warranty specifications. This leads to an on-site analytical instrument performance requirement of below 1.0 mg/kg for several elements.

#### 6. Interferences

6.1 *Spectral*—Most spectral interferences can be avoided by judicious choice of spectral lines. High concentrations of some elements can have an interfering influence on the spectral lines used for determining trace levels of contaminants. Instrument manufacturers usually compensate for spectral interferences during factory calibration. A background correction system, which subtracts unwanted intensities on the side of the spectral line, shall also be used for this purpose. When spectral interferences cannot be avoided with spectral line selection and background correction, the necessary corrections shall be made using the computer software supplied by the instrument manufacturer.

6.2 *Viscosity Effects*—Differences in viscosity of fuel samples will cause differences in uptake rates. Internal references of the instrument will compensate for a portion of the differences. Without a reference, the analysis will be adversely affected if the test specimen has a different viscosity from the calibration samples. The hydrogen 486.10 nm spectral line shall be used for light fuels, and the CN 387.10 nm spectral line shall be used for heavy fuels as an internal reference to compensate for viscosity effects.

6.3 *Particulate*—When large particles over 10 μm in size are present, the analytical results will be lower than the actual concentration they represent. Large particles may not be effectively transported by the rotating disk electrode sample introduction system into the arc, nor will they be fully vaporized.

#### 7. Apparatus

7.1 *Electrode Sharpener*—An electrode sharpener to remove the contaminated portion of the rod electrode remaining from the previous determination. It also forms a new 160° angle on the end of the electrode.

7.2 *Rotating Disc Electrode Atomic Emission Spectrometer*—A simultaneous spectrometer consisting of excitation source, polychromator optics, and readout system. Suggested wavelengths are listed in **Table 1**. When multiple

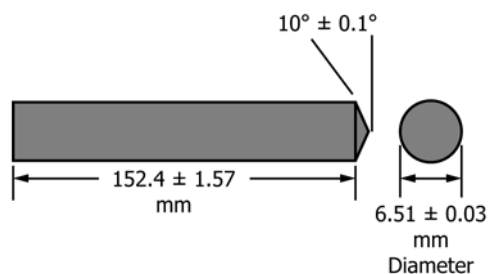

FIG. 1 Graphite Counter Electrode

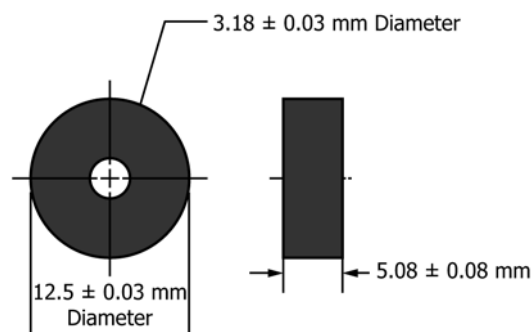

FIG. 2 Graphite Disc Electrode

wavelengths are listed, they are in the order of preference or desired analytical range.

**7.3 Heated Ultrasonic Bath (Recommended)**—An ultrasonic bath to heat and homogenize fuel samples to bring particles into suspension. The ultrasonic bath shall be used on samples containing large amounts of debris, those that have been in transit or in storage for at least 48 h and for heavy residual fuels to reduce viscosity effects.

**7.4 Power Mixer**—A power mixer should be used before a sample is transferred from one container to another to ensure that a homogeneous mixture is created and maintained until the transfer is complete. Practice D5854 should be consulted for the mixing and handling of liquid samples.

## 8. Reagents and Materials

**8.1 Base Oil**—A 75 cSt (40°C) base oil, free of analyte, to be used as a calibration blank or for blending calibration standards.

**8.2 Check Sample and Quality Control (QC) Samples**—One or more oil or fuel standards or samples of known concentration which are periodically analyzed as *go/no-go* samples to confirm the need for standardization based on an allowable accuracy limit as described in Appendix X1.

**8.3 Cleaning Solution**—An environmentally safe, non-chlorinated, rapid evaporating, and non-film producing solvent to remove spilled or splashed oil or fuel sample in the sample stand of the spectrometer.

**8.4 Counter Electrode**—The counter electrode is a rod electrode. The counter electrode shall be of high-purity graphite (spectroscopic grade). Dimensions of new counter electrodes shall conform to those shown in Fig. 1.

**8.5 Disc Electrode**—Graphite disc electrode of high-purity graphite (spectroscopic grade). Dimensions of the electrodes shall conform to those shown in Fig. 2.

**8.6 Glass Cleaning Solution**—Capable of cleaning and removing splashed oil or fuel sample from the quartz window that protects the entrance lens and fiber optic. Ammonia based window cleaner or 70 % isopropyl rubbing alcohol have been found to be suitable for this purpose.

**8.7 Organometallic Standards**—Single or multi-element blended standards for use as the high concentration standard for instrument standardization purposes or for use as a check sample to confirm calibration. Multi-element blends are used for fuel analysis applications that contain a 3:1 concentration

ratio of magnesium to all other metals present. The typical concentration for the upper calibration point is 10 mg/kg for light fuels when ASTM No. 0-GT, No. 1-GT, No. 2-GT, Grade 1-D, Grade 2-D, and Grade 4-D fuel samples are analyzed. The typical concentration for the upper calibration point is 100 mg/kg for heavy fuels when No. 3-GT and No. 4-GT fuel samples are analyzed.

8.7.1 Standards have a shelf-life and shall not be used to standardize an instrument if they have exceeded the expiration date.

**8.8 Specimen Holders**—A variety of specimen holders can be used for the analysis of fuel samples. Disposable specimen holders must be discarded after each analysis and reusable specimen holders must be cleaned after each analysis. All specimen holders must be free of contamination and shall be stored accordingly. Specimen holder covers shall be used on those fuel samples that may catch on fire during the analysis.

## 9. Sampling

9.1 The fuel sample taken for the analysis must be representative of the entire system. Good sampling procedures are key to good analyses and samples must be taken in accordance with Practice D4057.

## 10. Preparation of Test Specimen

**10.1 Homogenization**—Fuel samples may contain particulate matter and free water and, in order to be representative, must always be vigorously shaken prior to pouring a test specimen for analysis.

**10.2 Ultrasonic Homogenization**—Samples that have been in transit for several days, idle in storage or very viscous, shall be placed in a heated ultrasonic bath to break up clusters of particles and to bring them back into suspension. The samples shall be vigorously shaken with a power mixer after being in the ultrasonic bath and prior to pouring a test specimen for analysis. The bath temperature shall be 60°C for very viscous fuels and below the flash point of non viscous fuels. The total agitation time for a sample should be at least 2 min.

**10.3 Specimen Holders**—Fuel samples and oil standards shall be poured into a specimen holder of at least 1 mL capacity prior to analysis. Exercise care to pour the sample consistently to the same level in the specimen holders.