

INTERNATIONAL STANDARD

**ISO
2853**

Second edition
1993-06-15

Stainless steel threaded couplings for the food industry

iTeh STANDARD PREVIEW
Raccords filetés en acier inoxydable pour l'industrie alimentaire
(standards.iteh.ai)

ISO 2853:1993

<https://standards.iteh.ai/catalog/standards/sist/cd6fe634-27e5-4a35-8a7a-d648ff9190e8/iso-2853-1993>



Reference number
ISO 2853:1993(E)

Contents

	Page
1 Scope	1
2 Normative references	1
3 Symbols	1
4 Dimensions and tolerances	2
4.1 Expanded-type male part	2
4.2 Expanded-type liner	2
4.3 Welded-type male part	2
4.4 Welded-type liner	2
4.5 Hexagon nut	2
4.6 Round nut	2
4.7 Gasket	2
4.8 Support ring	2
5 Assembling	3
5.1 Welding	3
5.2 Expanding	3
6 Hygienic requirements	3
7 Surface roughness	3
8 Materials	3
8.1 Male parts, liners, nuts and support rings.	3
8.2 Gaskets	3

iTeh STANDARD PREVIEW
(standards.iteh.ai)

<https://standards.iteh.ai/catalog/standards/sist/cd6fe634-27e5-4a35-8a7a-d6488d190e8/iso-2853-1993>

<https://standards.iteh.ai/catalog/standards/sist/cd6fe634-27e5-4a35-8a7a-d6488d190e8/iso-2853-1993>

© ISO 1993

All rights reserved. No part of this publication may be reproduced or utilized in any form or by any means, electronic or mechanical, including photocopying and microfilm, without permission in writing from the publisher.

International Organization for Standardization
Case Postale 56 • CH-1211 Genève 20 • Switzerland

Printed in Switzerland

Annexes

A	Trapezoidal threads intended for threaded couplings	12
B	Cross-section of threaded coupling assembly	16
C	Specifications of the gasket	17
D	Grooving for expanded-type male parts and liners	18
E	Lock rings for expanded-type male parts and liners	20
F	Method of expansion with straight pipe	21
G	Bibliography	23

iTeh STANDARD PREVIEW
(standards.iteh.ai)

[ISO 2853:1993](https://standards.iteh.ai/catalog/standards/sist/cd6fe634-27e5-4a35-8a7a-d648ff9190e8/iso-2853-1993)

<https://standards.iteh.ai/catalog/standards/sist/cd6fe634-27e5-4a35-8a7a-d648ff9190e8/iso-2853-1993>

Foreword

ISO (the International Organization for Standardization) is a worldwide federation of national standards bodies (ISO member bodies). The work of preparing International Standards is normally carried out through ISO technical committees. Each member body interested in a subject for which a technical committee has been established has the right to be represented on that committee. International organizations, governmental and non-governmental, in liaison with ISO, also take part in the work. ISO collaborates closely with the International Electrotechnical Commission (IEC) on all matters of electrotechnical standardization.

Draft International Standards adopted by the technical committees are circulated to the member bodies for voting. Publication as an International Standard requires approval by at least 75 % of the member bodies casting a vote.

International Standard ISO 2853 was prepared by Technical Committee ISO/TC 5, *Ferrous metal pipes and metallic fittings*, Sub-Committee SC 1, *Steel tubes*.

[ISO 2853:1993](http://standards.iteh.ai/catalog/standards/sist/cd6f634-27e5-4a35-8a7a-16480190-82/iso-2853-1993)

This second edition cancels and replaces the first edition (ISO 2853:1976), all the tables of which have been technically revised.

Annexes A, B, C, D and E form an integral part of this International Standard. Annexes F and G are for information only.

Stainless steel threaded couplings for the food industry

1 Scope

This International Standard specifies the dimensions, tolerances, surface roughness, materials, assembling and hygienic requirements for

- a) welded- and expanded-type male parts and liners, and
- b) nuts and gaskets,

in stainless steel threaded pipe couplings for the food industry.

Male parts and liners in stainless steel threaded couplings for the food industry are intended to be used with stainless steel tubes specified in ISO 2037.

2 Normative references

The following standards contain provisions which, through reference in this text, constitute provisions of this International Standard. At the time of publication, the editions indicated were valid. All standards are subject to revision, and parties to agreements based on this International Standard are encouraged to investigate the possibility of applying the most recent editions of the standards indicated below. Members of IEC and ISO maintain registers of currently valid International Standards.

ISO 48:1979, *Vulcanized rubbers — Determination of hardness (Hardness between 30 and 85 IRHD)*.

ISO 286-2:1988, *ISO system of limits and fits — Part 2: Tables of standard tolerance grades and limit deviations for holes and shafts*.

ISO 2037:1992, *Stainless steel tubes for the food industry*.

ISO 2604-1:1975, *Steel products for pressure purposes — Quality requirements — Part 1: Forgings*.

ISO 6506:1981, *Metallic materials — Hardness test — Brinell test*.

ISO 6507-1:1982, *Metallic materials — Hardness test — Vickers test — Part 1: HV 5 to HV 100*.

ISO 6508:1986, *Metallic materials — Hardness test — Rockwell test (scales A - B - C - D - E - F - G - H - K)*.

3 Symbols

A	allowance of male part thread
B_1	inside diameter of support ring
B_2	outside diameter of support ring
C_1	spigot diameter of expanded-type male part and liner
C_2	spigot diameter of welded-type male part and liner
C_3	inside diameter of hexagon or round nut
C_4	inside diameter of gasket
C_5	inside diameter of expanded-type male part and liner
C_6	inside diameter of welded-type male part and liner
C_7	outside diameter of expanded- or welded-type liner
C_8	outside diameter of round nut
C_9	centring inside diameter of nut
C_{10}	outside diameter of neck of welded-type male part and liner
d	major diameter of male part thread
d_1	minor diameter of male part thread

d_2	pitch diameter of male part thread
D	major diameter of nut thread
D_1	minor diameter of nut thread
D_2	pitch diameter of nut thread
E	inside diameter of gasket lip
F_1	total length of expanded-type male part
F_2	total length of welded-type male part and liner
F_3	total length of expanded-type liner
F_4	total length of hexagon or round nut
F_5	inside width of support ring
G_1	length of external thread of expanded- and welded-type male part
G_2	length of internal thread of hexagon or round nut
H	height of fundamental triangle of thread
J	chamfer diameter of round nut
K	length of spigot of expanded- and welded-type male part and liner
L_1	flange thickness of expanded- and welded-type liner
L_2	inside flange thickness of hexagon or round nut
M_1	outside diameter of lip of gasket to be used with support ring
M_2	outside diameter of lip of gasket to be used without support ring
N_1	width across slots of round nut
N_2	width across flats of hexagon nut
O	width of slot of round nut
p	pitch of thread
R_1	fillet radius of welded-type male part
R_2	fillet radius of welded-type liner
S	outside diameter of gasket (lip excluded) to be used with support ring
T_2	length of lip of gasket to be used with support ring
T_3	wall thickness of support ring
U	total thickness of gasket
V	compression thickness of gasket
w	root width of male part threads on GO side profile

W	root width of nut threads on GO side profile
X_1	lock ring groove diameter
X_2	lock ring outside diameter
α_1	angle of chamfer of round nut
α_2	angle of neck of support ring

4 Dimensions and tolerances

4.1 Expanded-type male part

The dimensions and tolerances, in millimetres, and the tolerance classes (see ISO 286-2) are given in figure 1 and table 1.

4.2 Expanded-type liner

The dimensions and tolerances, in millimetres, and the tolerance classes (see ISO 286-2) are given in figure 2 and table 2.

4.3 Welded-type male part

The dimensions and tolerances, in millimetres, and the tolerance classes (see ISO 286-2) are given in figure 3 and table 3.

4.4 Welded-type liner

The dimensions and tolerances, in millimetres, and the tolerance classes (see ISO 286-2) are given in figure 4 and table 4.

4.5 Hexagon nut

The dimensions and tolerances, in millimetres, and the tolerance classes (see ISO 286-2) are given in figure 5 and table 5.

4.6 Round nut

The dimensions and tolerances, in millimetres, and the tolerance classes (see ISO 286-2) are given in figure 6 and table 6.

4.7 Gasket

The dimensions and tolerances, in millimetres, are given in figure 7 and table 7.

For the specifications of the gasket, see annex C.

4.8 Support ring

The dimensions and tolerances, in millimetres, are given in figure 8 and table 8.

5 Assembling

5.1 Welding

Welded-type male parts and liners shall be attached to the pipe ends by butt welding.

5.2 Expanding

Expanded-type male parts and liners shall be attached to the pipe ends by expanding. A method for carrying out the expansion is described in annex F. This method can be applied to nominal sizes up to and including 101,6 mm.

6 Hygienic requirements

6.1 All surfaces of the coupling in contact with the foodstuff shall be easily accessible for cleaning, either by cleaning in place methods or by manual cleaning when disassembled. Removable parts shall be readily demountable.

6.2 The interior surface of welded-type male parts and liners shall be clean and smooth. It shall be free from surface defects and inclusions.

6.3 The gasket shall be made of a material compatible with the material of the fitting, with the foodstuffs and with the cleaning fluids utilized. It shall not, for example, impart an odour or taste to the foodstuff.

7 Surface roughness

The surface roughness of expanded- and welded-type male parts and liners, nuts and support rings, in accordance with the specifications of ISO 468, shall be, for finely finished surfaces, $R_a \leq 1 \mu\text{m}$.

8 Materials

8.1 Male parts, liners, nuts and support rings.

Austenitic stainless steel shall be selected from ISO 2604-1.

Generally the steel types F47 and F62 are suitable (similar to the types recommended for tubes in ISO 2037).

8.2 Gaskets

The gaskets shall be of natural or synthetic rubber with a hardness from 75 IRHD to 85 IRHD in accordance with ISO 48. The material shall meet the hygienic requirements and have a reasonable life expectancy.

ITeC STANDARD PREVIEW
(standards.itec.ai)
ISO 2853:1993
<https://standards.itec.ai/catalog/standards/sist/cd6fe634-27e5-4a35-8a7a-d648ff9190e8/iso-2853-1993>

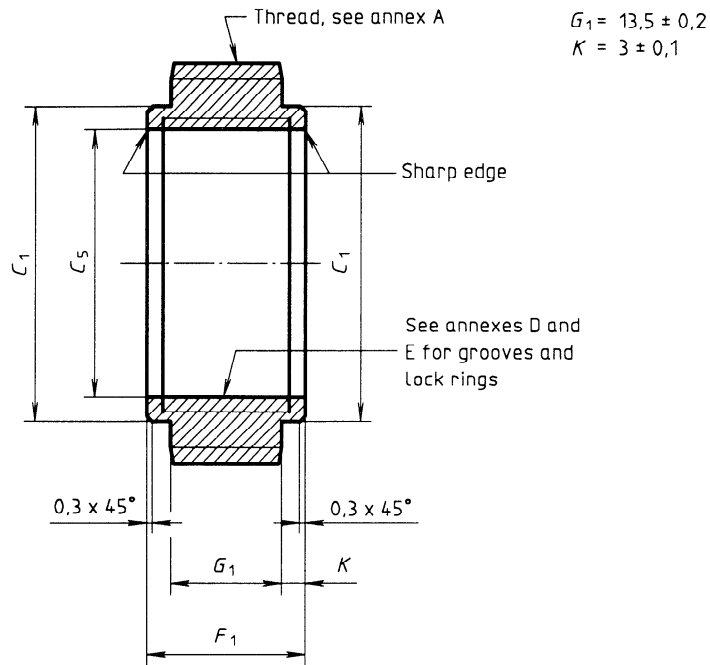

Figure 1
 iTeh STANDARD PREVIEW
 (standards.iteh.ai)

ISO 2853:1993
Table 1

Nominal size	C_1 h10	C_5 A10	F_1 $\pm 0,2$
12	15	12	17
12,7	15	12,7	17
17,2	21,2	17,2	17
21,3	25,4	21,3	17
25	29	25	17
33,7	38	33,7	20
38	42,5	38	20
40	44,5	40	20
51	56	51	20
63,5	69,7	63,5	25
70	76,2	70	25
76,1	82,3	76,1	30

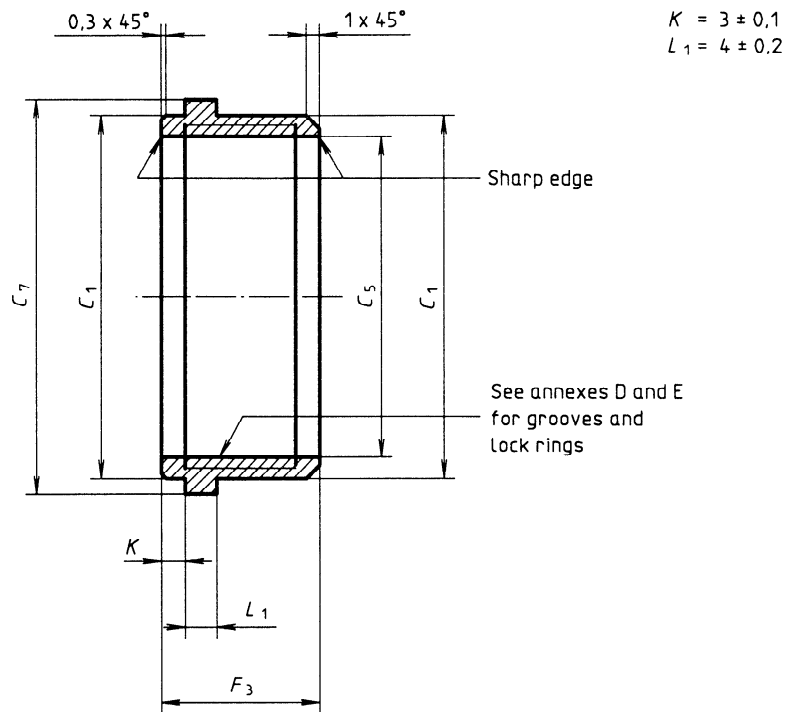

Figure 2
 iTeh STANDARD PREVIEW
 (standards.iteh.ai)

ISO 2853:1993
Table 2

Nominal size	C_1 h10	C_5 A10	C_7 h10	F_3 $\pm 0,2$
12	15	12	19,6	16
12,7	15	12,7	19,6	16
17,2	21,2	17,2	25,8	18
21,3	25,4	21,3	30	20
25	29	25	33,8	20
33,7	38	33,7	42,5	20
38	42,5	38	47	20
40	44,5	40	49	20
51	56	51	60,5	25
63,5	69,7	63,5	74	30
70	76,2	70	80,9	30
76,1	82,3	76,1	87,5	30

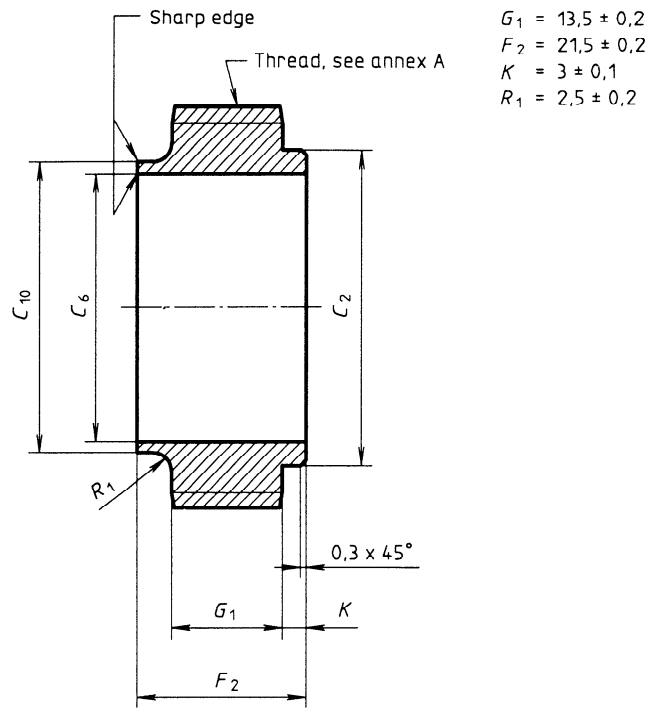

Figure 3
iTeh STANDARD PREVIEW
(standards.iteh.ai)

Table 3

Nominal size	C_2 h10	C_6 N11	C_{10} h11
25	29,2	22,6	25,6
33,7	38,2	31,3	34,3
38	42,7	35,6	38,6
40	44,7	37,6	40,6
51	56,2	48,6	51,6
63,5	69,9	60,3	64,1
70	76,4	66,8	70,6
76,1	82,6	72,9	76,7

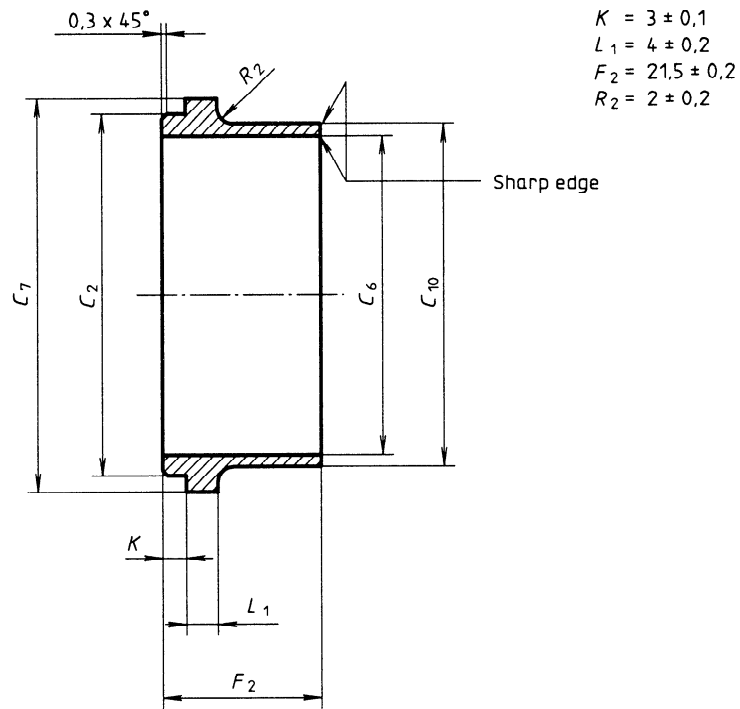

Figure 4
iTeh STANDARD PREVIEW
(standards.iteh.ai)

Table 4

Nominal size	C_2 h10	C_6 N11	C_7 h10	C_{10} h11
25	29,2	22,6	33,8	25,6
33,7	38,2	31,3	42,5	34,3
38	42,7	35,6	47	38,6
40	44,7	37,6	49	40,6
51	56,2	48,6	60,5	51,6
63,5	69,9	60,3	74	64,1
70	76,4	66,8	80,9	70,6
76,1	82,6	72,9	87,5	76,7
88,9	95,7	84,9	101	89,8
101,6	108,7	97,6	114,1	102,5