



# Standard Test Method for Air Permeance of Building Materials<sup>1</sup>

This standard is issued under the fixed designation E2178; the number immediately following the designation indicates the year of original adoption or, in the case of revision, the year of last revision. A number in parentheses indicates the year of last reapproval. A superscript epsilon ( $\epsilon$ ) indicates an editorial change since the last revision or reapproval.

## 1. Scope

1.1 This test method is to determine the air permeance of building materials at various pressure differentials with the intent of determining an assigned air permeance rate of the material at the reference pressure difference ( $\Delta P$ ) of 75 Pa.

1.2 The method is intended to assess flexible sheet or rigid panel-type materials using a 1 m  $\times$  1 m specimen size.

1.3 The values stated in SI units are to be regarded as standard. No other units of measurements are included in this standard.

1.4 *This standard does not purport to address all of the safety concerns, if any, associated with its use. It is the responsibility of the user of this standard to establish appropriate safety and health practices and determine the applicability of regulatory limitations prior to use.*

## 2. Referenced Documents

2.1 *ASTM Standards:*<sup>2</sup>

E283 [Test Method for Determining Rate of Air Leakage Through Exterior Windows, Curtain Walls, and Doors Under Specified Pressure Differences Across the Specimen](#)

E631 [Terminology of Building Constructions](#)

E1677 [Specification for Air Barrier \(AB\) Material or System for Low-Rise Framed Building Walls](#)

## 3. Terminology

3.1 *Definitions:*

~~3.1.1~~

3.1.1 For definitions of general terms related to building construction used in this test method, refer to Terminology E631.

3.2 *Definitions of Terms Specific to This Standard:*

3.2.1 air permeance—the rate of air flow (L/s), per unit area (m<sup>2</sup>) and per unit static pressure differential (Pa).

## 4. Significance and Use

4.1 The purpose of this test is to measure the air permeance of flexible sheet or rigid panel-type materials. The results of this test may be useful in determining suitability of that material as a component of an air retarder system.

4.2 This method does not address the installed air leakage performance of building materials. The installed performance of air retarder materials and air retarder systems in low-rise framed wall construction is addressed in Specification E1677.

## 5. Sampling

5.1 The number of specimens to be tested shall be suitable to establish an air leakage rate which is representative of the product. In no case shall less than five specimens be tested.

NOTE 1—Because of the variability in the manufacture of a product, the number of specimens to be tested may vary from product to product. Certain materials may have standard methods for sampling that shall be used to sample these materials.

## 6. Test Apparatus

6.1 A schematic of the air leakage test apparatus is presented in Fig. 1.

6.1.1 *Airtight Test Chamber*—The airtight test chamber shall be at least 320 mm deep and capable of receiving a 1 m by 1 m

<sup>1</sup> This test method is under the jurisdiction of ASTM Committee E06 on Performance of Buildings and is the direct responsibility of Subcommittee E06.41 on Air Leakage and Ventilation Performance.

Current edition approved Aug. 10, 2003. Published October 2003. Originally approved in 2001. Last previous edition approved in 2001 as E2178-01. DOI: 10.1520/E2178-03.

Current edition approved Nov. 1, 2011. Published December 2011. Originally approved in 2001. Last previous edition approved in 2003 as E2178-03. DOI: 10.1520/E2178-11.

<sup>2</sup> For referenced ASTM standards, visit the ASTM website, www.astm.org, or contact ASTM Customer Service at service@astm.org. For Annual Book of ASTM Standards volume information, refer to the standard's Document Summary page on the ASTM website.

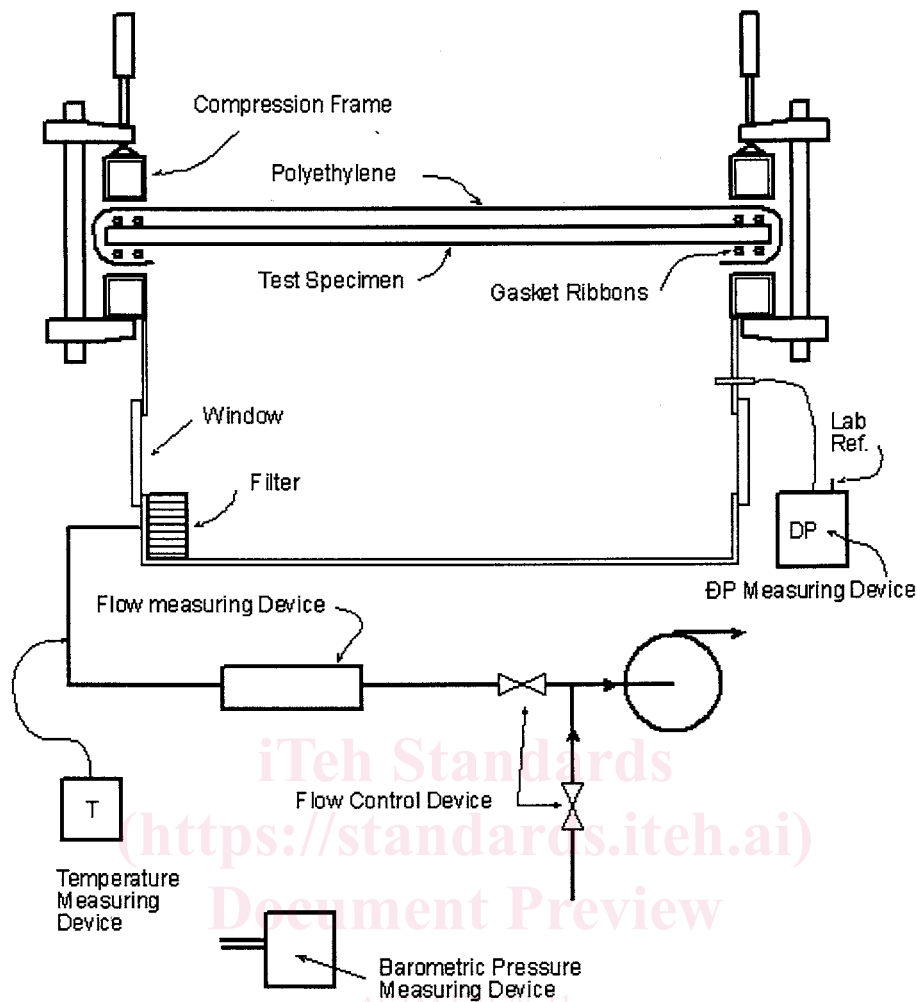

FIG. 1 General Configuration of Test Apparatus

test specimen, anchored to the test chamber by means of a compression frame and clamping devices. The test chamber and compression frame shall be stiff enough to limit deflection within the operating flexibility of the gaskets used to seal the test specimen to the chamber. Two parallel ribbons of self-adhesive gasket material shall be applied at all sealing points of the apparatus/test specimen assembly. The gasket ribbons shall be made of medium-density gasket material that can be fused or glued at joints. The test apparatus shall contain an over-pressure control device and windows to verify the specimen installation.

6.1.2 *Flow Measuring Devices*—The flow measuring devices used to gage the air flow through the test specimen shall be capable of measuring air flow rate from  $1 \times 10^{-6} \text{ m}^3/\text{s}$  (.001 L/s) up to  $1.88 \times 10^{-2} \text{ m}^3/\text{s}$  (18.8 L/s), with an accuracy of  $\pm 3 \%$  of the reading.

6.1.3 *Pressure Measuring Devices*—The static pressure differential across the test specimen shall be measured by pressure measuring devices with an accuracy of  $\pm 0.5 \%$  of the pressure reading. The laboratory barometric pressure shall be measured with a device capable of measuring barometric pressure within  $\pm 3 \%$  of the reading.

6.1.4 *Piping*—The piping connecting the flow measuring devices and the vacuum blower shall be airtight and contain flow control devices to regulate the static pressure across the test specimen within  $\pm 0.5 \%$  of the pressure reading. The pipe connection to the test chamber shall contain an air filter to prevent dust or particulate matter from affecting the flow measuring device reading. The piping downstream and upstream of the flow measuring device shall be designed so the flow regime does not affect the device's accuracy. The piping shall contain a temperature measuring device capable of measuring air temperature within  $\pm 0.5^\circ\text{C}$  to convert all flow rate measurement to STP.

6.1.5 *Vacuum Blower*—The blower used to create a vacuum in the test chamber shall be able to produce static pressure differential across the test specimen within  $\pm 0.5 \%$  of the pressure reading.

## 7. Specimen Preparation

7.1 *Conditioning for Tests*—Unless otherwise stated, all specimens to be tested shall be conditioned for a minimum period of seven days at  $21 \pm 1^\circ\text{C}$  and  $40 \pm 5 \%$  RH.

7.2 *Flexible Sheet Materials*—Due to lack of rigidity, flexible materials shall be tested over a rigid support having an air permeance much greater than the test specimen. An open grill or wire mesh/screen, fabricated with welded wire having a minimum of 25 mm × 25-mm-square grid (or an alternative means that provides an equivalent degree of support and air permeance) shall be used for this purpose. The wire mesh portion of the support shall be welded or otherwise mechanically secured to a solid metal frame which shall be gasketed and compressed within the test frame. A detailed description of the support grill, including the gage wire used, shall be included in the test report. Fig. 2 shows the preparation for a typical flexible sheet material. The following procedure shall be used to seal the perimeter of the specimen:

7.2.1 Apply a self-adhesive gasket ribbon over the frame of the wire mesh/screen around the entire perimeter of the test area under investigation (1 m × 1 m);

7.2.2 Apply a second self-adhesive gasket ribbon along the perimeter of the first ribbon in 7.2.1;

7.2.3 All joints in the gasket ribbons shall be fused or glued;

7.2.4 Cut the flexible sheet material specimen to 1100 mm × 1100 mm;

7.2.5 Upon removal of the protective paper over the self-adhesive gasket, install the specimen over the wire mesh/screen;

7.2.6 Apply the self-adhesive gasket over the specimen so it lines up with the first ribbon in 7.2.1, and then apply a second self-adhesive gasket along its perimeter;

7.2.7 All joints in the gasket ribbons shall be fused or glued;

7.2.8 Cut polyethylene film (0.15 mm (6 mils)) to 1400 mm × 1400 mm;

7.2.9 Upon removal of the protective paper over the ribbon, cover the specimen with the polyethylene film;

7.2.10 Cut the polyethylene film at each corner as per Fig. 3;

7.2.11 Apply two self-adhesive gaskets to the underside of the wire mesh/screen support (the gaskets shall line up below the first ribbon installed in 7.2.1);

7.2.12 Upon removal of the protective paper over the gasket, fold and tape each corner of the film with construction tape to ensure complete airtightness as per Fig. 4;

7.2.13 From the interior line of the adhesive gasket, cut and remove all the excess polyethylene film.

7.3 *Rigid Panel-Type Materials*—Fig. 5 shows the preparation for a typical rigid panel-type material. The following procedure shall be used to seal the perimeter of the specimen:

7.3.1 Apply a self-adhesive gasket ribbon over the rigid panel-type test specimen around the entire perimeter of the area under investigation (1 m × 1 m);

7.3.2 All joints in the gasket ribbons shall be fused or glued;

7.3.3 Cut polyethylene film (0.15 mm (6 mils)) to 1400 mm × 1400 mm;

7.3.4 Upon removal of the protective paper over the self-adhesive gasket ribbon, cover the specimen with the polyethylene film;

7.3.5 Cut the polyethylene film at each corner as per Fig. 3;

7.3.6 Apply a second self-adhesive gasket ribbon to the underside of the specimen (the ribbon shall be applied directly below the first ribbon installed in 7.3.1), and seal corner junctions by fusing or gluing;

<https://standards.iteh.ai/catalog/standards/sist/3374f155-b9db-4944-8dc7-cff2cc5f978b/astm-e2178-11>

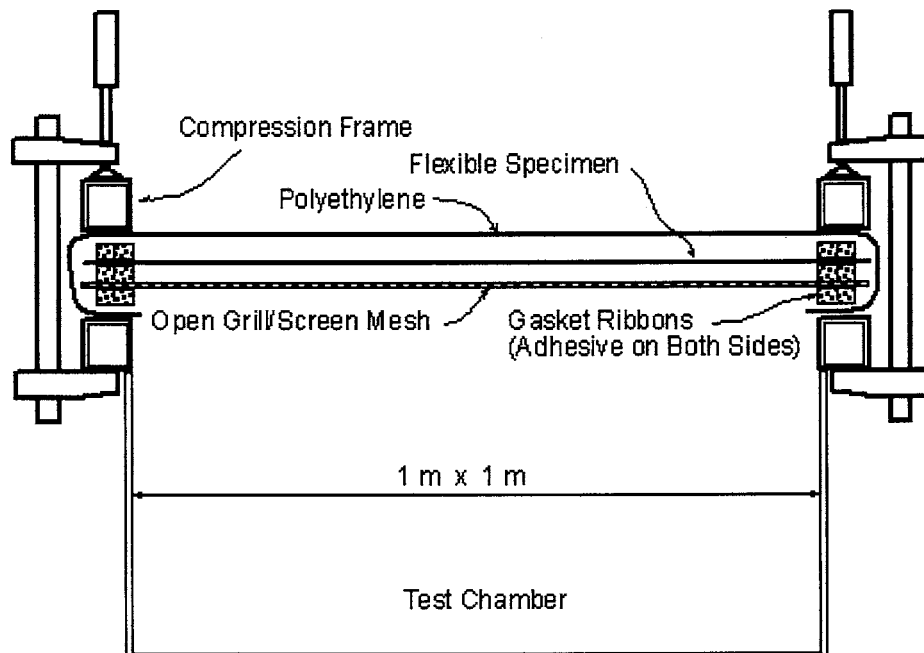

FIG. 2 Flexible Sheet Test Specimen

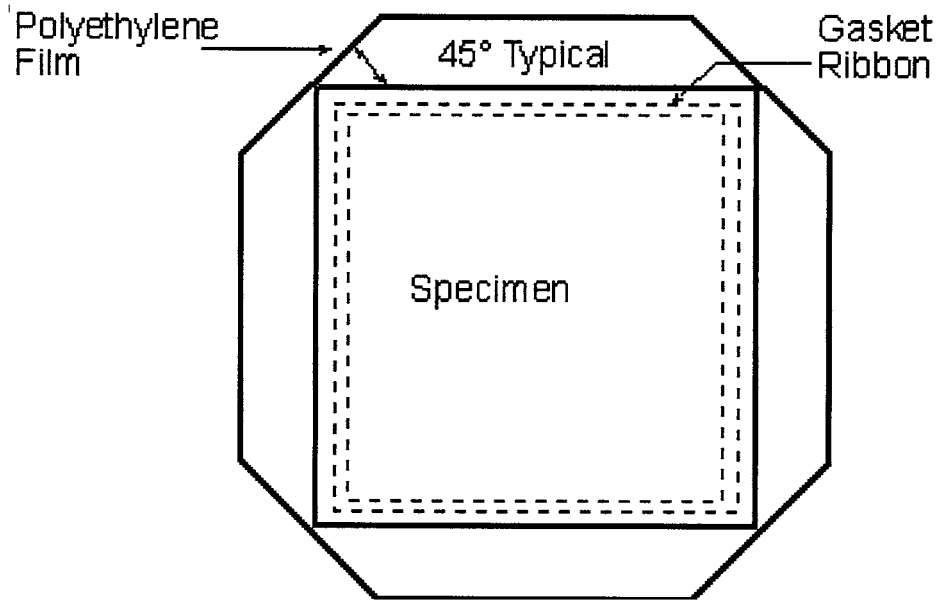

FIG. 3 Top View of Polyethylene Placement Over Specimen with Double Perimeter Gaskets

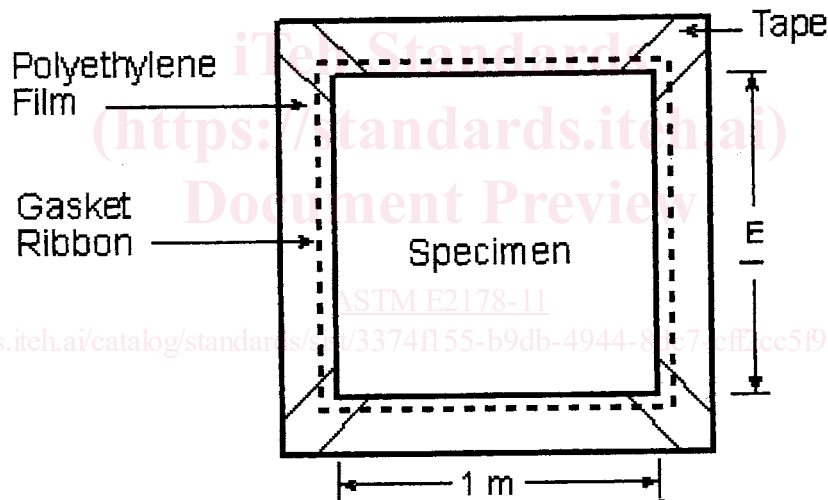

FIG. 4 Bottom View of Polyethylene Seal at Double-Perimeter Gaskets on Underside of Rigid Panel-Type Specimen or Open Mesh/Screen for Flexible Sheet Specimen Set-up

7.3.7 Upon removal of the protective paper over the self-adhesive gasket ribbon, fold and tape each corner of the film with construction tape to ensure complete airtightness as per Fig. 4;

7.3.8 From the interior line of the self-adhesive gasket ribbon, cut and remove all the excess polyethylene film.

## 8. Test Procedure

8.1 *Control Tests*—The laboratory shall confirm the integrity and accuracy of the apparatus by verifying the following:

8.1.1 The impact of the open mesh/screen on the air leakage rate measurements shall be assessed. If not negligible, it shall be taken into account when calculating the air permeance.

8.1.2 The air leakage rate across one specimen of a 12.5-mm-thick regular gypsum board shall be determined in accordance with procedures outlined in 7.3, for a rigid panel-type material. The air leakage rate of the regular gypsum board shall not exceed  $0.02 \text{ L}/(\text{s} \cdot \text{m}^2)$  at a pressure differential of 75 Pa.

8.2 *Specimen Testing*—The testing on each specimen shall be conducted as follows:

8.2.1 Install the sealed test specimen on the test chamber;

8.2.2 Install the compression frame over the specimen;

8.2.3 Check through the window if the specimen is properly placed;