



Designation: ~~E1414/E1414M-11~~ Designation: E1414/E1414M – 11a

Standard Test Method for Airborne Sound Attenuation Between Rooms Sharing a Common Ceiling Plenum¹

This standard is issued under the fixed designation E1414/E1414M; the number immediately following the designation indicates the year of original adoption or, in the case of revision, the year of last revision. A number in parentheses indicates the year of last reapproval. A superscript epsilon (ϵ) indicates an editorial change since the last revision or reapproval.

INTRODUCTION

This test method is designed to measure the sound attenuation provided by a suspended ceiling in the presence of a continuous plenum space under prescribed laboratory test conditions. The test method is an adaptation of AMA 1-II-1967 Method of Test. This modified test method may give results differing from the AMA-1-II procedure.

1. Scope

1.1 This test method utilizes a laboratory space so arranged that it simulates a pair of horizontally adjacent small offices or rooms separated by a partition and sharing a common plenum space. The partition either extends to the underside of a common plenum space or penetrates through it. In the prescribed configuration, special design features of the facility ensure that the only significant sound transmission path is by way of the ceiling and the plenum space

1.2 Within the limitations outlined in the significance statement, the primary quantity measured by this test method is the ceiling attenuation of a suspended ceiling installed in a laboratory environment. By accounting for receiving room sound absorption, the normalized ceiling attenuation may be determined.

1.3 The test method may also be used to evaluate the attenuation of composite ceiling systems comprised of the ceiling material and other components such as luminaires and ventilating systems.

1.4 The field performance of a ceiling system may differ significantly from the results obtained by this test method (see Section 5, Significance and Use, and Test Method E336).

1.5 The procedures may also be used to study the additional sound insulation that may be achieved by other attenuation measures. This would include materials used either as plenum barriers or as backing for all or part of the ceiling.

1.6 The facility may also be used to study the performance of an integrated system comprising plenum, ceiling, and partition, tested as a single assembly.

1.7 The values stated in either SI units or inch-pound units are to be regarded separately as standard. The values stated in each system may not be exact equivalents; therefore, each system shall be used independently of the other. Combining values from the two systems may result in non-conformance with the standard.

1.8 *This standard does not purport to address all of the safety concerns, if any, associated with its use. It is the responsibility of the user of this standard to establish appropriate safety and health practices and determine the applicability of regulatory limitations prior to use.*

2. Referenced Documents

2.1 ASTM Standards:²

C423 [Test Method for Sound Absorption and Sound Absorption Coefficients by the Reverberation Room Method](#)

C634 [Terminology Relating to Building and Environmental Acoustics](#)

C636 [Practice for Installation of Metal Ceiling Suspension Systems for Acoustical Tile and Lay-In Panels](#)

E90 [Test Method for Laboratory Measurement of Airborne Sound Transmission Loss of Building Partitions and Elements](#)

E177 [Practice for Use of the Terms Precision and Bias in ASTM Test Methods](#)

E336 [Test Method for Measurement of Airborne Sound Attenuation between Rooms in Buildings](#)

¹ This test method is under the jurisdiction of ASTM Committee E33 on Building and Environmental Acoustics and is the direct responsibility of Subcommittee E33.03 on Sound Transmission.

Current edition approved April 1, 2011. Published May 2011. Originally approved in 1991. Last previous edition approved in 2006 as E1414-06-E1414-11. DOI: 10.1520/E1414_E1414M-11A.

² For referenced ASTM standards, visit the ASTM website, www.astm.org, or contact ASTM Customer Service at service@astm.org. For *Annual Book of ASTM Standards* volume information, refer to the standard's Document Summary page on the ASTM website.

E413 Classification for Rating Sound Insulation E548 Guide for General Criteria Used for Evaluating Laboratory Competence
 E691 Practice for Conducting an Interlaboratory Study to Determine the Precision of a Test Method

2.2 *ANSI Standards:*

S1.11 Specification for Octave-Band and Fractional-Octave Band Analog and Digital Filters³

2.3 *Other Standards:*

AMA 1-II-1967 Method of Test, Standard Specification for Ceiling Sound Transmission Test by Two Room Method⁴

3. Terminology

3.1 *Definitions*—For definitions of terms used in this test method see Terminology C634.

3.2 *Definitions of Terms Specific to This Standard:*

3.2.1 *ceiling attenuation* (D_c)—the noise reduction between the source and receiving rooms where flanking transmission by all paths are at least 10 decibels lower than the path through the ceiling and plenum.

$$D_c = \bar{L}_1 - \bar{L}_2 \quad (1)$$

where \bar{L}_1 is the average one-third octave band sound pressure level in the source room; \bar{L}_2 is the average one-third octave band sound pressure level in the receiving room.

3.2.2 *normalized ceiling attenuation* ($D_{n,c}$)—the ceiling attenuation adjusted to account for receiving room absorption.

$$D_{n,c} = D_c + N_f \quad (2)$$

where N_f is the normalization term defined in 3.2.3.

3.2.3 *normalization term* (N_f)—the adjustment term determined in 9.3 which normalizes the ceiling attenuation to account for receiving room absorption.

3.2.4 *ceiling attenuation class* (CAC)—a single figure rating derived from the normalized ceiling attenuation values in accordance with Classification E413, except that the resultant rating shall be designated *ceiling attenuation class*.

3.2.5 *plenum space*—the whole of the void above the suspended ceilings in both rooms. Its dimensions are to be measured, discounting the thickness of any sound absorbing material either adhered to walls or laid on the back of the test ceiling.

3.2.6 *direct sound field*—the sound that results from an acoustical source without reflection from boundaries.

3.2.7 *reverberant sound field*—the sound in an enclosed or partially enclosed space that has been reflected repeatedly from the enclosure boundaries.

4. Summary of Test Method

4.1 The laboratory test facility consists of an outer shell divided into two rooms by a partition and a suspended ceiling (the test specimen). The partition between the two rooms may extend up to, or through, the suspended ceiling, depending upon whether the specific test specimen is designed to be continuous or interrupted at the partition line. The rooms are built so that the only significant sound transmission path between them is that provided by the test specimen and the ceiling plenum. All other sound transmission paths must be negligible. The ceiling attenuation is determined in each of the test frequency bands, by placing a sound source in one room and then calculating the difference of the average sound pressure levels in both rooms. For the purposes of this test method, the room containing the sound source is designated the *source room* and the other, the *receiving room*.

4.2 The measurement of a normalized ceiling attenuation requires that the value of a normalization term dependent upon the amount of sound absorption present in the receiving room be known. Two alternate methods are used for the determination of this normalization term.

5. Significance and Use

5.1 Modern offices and other multipurpose buildings commonly have suspended acoustical ceilings installed over room dividing partitions. The test facility prescribed in this test method is useful for providing ceiling attenuation data on the relevant ceiling/partition elements and systems, to ensure that the transmission of sound through the ceiling and plenum space, or through the combination of ceiling, plenum space, and partition systems, provides a suitable degree of acoustical isolation.

5.2 This test method is useful for rating and specifying, under standardized conditions, the sound attenuation performance of ceiling materials when mounted in a specified suspension system.

5.3 This test method may be useful for selecting a wall-ceiling system for probable compliance with a performance specification for overall sound isolation between rooms. However, the actual field performance may differ significantly, particularly if the field plenum depth is not within the limits specified in this test method or if the plenum space contains large ducts, beams, etc., or both. (See Test Method E336.)

³ Available from American National Standards Institute (ANSI), 25 W. 43rd St., 4th Floor, New York, NY 10036, <http://www.ansi.org>.

⁴ Method of the American Board Products Assoc., (formerly Acoustical Materials Assoc.) available from Ceiling and Interior Systems Contracting Assoc., 1800 Pickwick Ave., Glenview, IL 60025.

5.4 The flexibility inherent in the test facility enables evaluation of the effects of penetrations, induced leakage paths, luminaire, and air diffuser installations and discontinuities in the ceiling suspension system at the partition line, including penetration of the partition into the ceiling plenum. The effect of installing plenum barriers at the partition line may also be investigated.

5.5 With the concentration of sound absorbent area offered by a suspended sound absorbent ceiling installed in a room, it is not possible to obtain a good approximation to a diffuse sound field in that room. The plenum dimensions prevent the maintenance of a diffuse sound field above the test specimen. These factors affect the values of the measured ceiling sound attenuation and thus the measurements are not a fundamental property of the ceiling. The test method measures the acoustical properties attainable under the prescribed test conditions, which have been arbitrarily selected. The conditions must be adhered to in every test facility so that the measured results will be consistent. Two methods for obtaining *A*, the receiving room absorption, are given without preference. One method, known as the steady state method, has been used to obtain an estimate for *A* in the AMA 1-II-1967 standard. The other method follows the procedures used in Test Methods E90 and C423; justification for the use of this method may be found in reference (1)⁵. Persons wishing to further investigate the limitations imposed by this test method are advised to read references (2), (3), (4) and (5).

5.6 Notwithstanding the above limitations, this type of test method has been used successfully for a number of years to rank order commercial ceiling systems and the test results are commonly used for this purpose.

6. Test Signal

6.1 *Signal Spectrum*— The sound signal used for this test shall constitute a band or bands of random noise with a continuous distribution of frequencies over each test band.

6.2 *Bandwidth*—The measurement bandwidth shall be one-third octave. Specifically the overall frequency response of the filter or filters, in the source and microphone amplifiers, shall conform to ANSI Specification S 1.11-2004 (R2009) for class 1, 1/3 octave band filters.

6.3 *Standard Test Frequencies*—The minimum frequency range shall be a series of contiguous one-third octave bands with geometric center frequencies from 125 to 4000 Hz.

7. Test Arrangement

7.1 The essential features of the test facility are given below.

7.1.1 *Room Construction*—The rooms shall be rectangular in shape and cross-section. The walls, floor, doors, and roof should provide sufficient acoustical isolation to reduce external noise levels to at least 10 dB below the lowest test signal level. The sound absorption in each of the rooms should be made as low as possible in order to achieve the best possible diffuse field condition. The average sound absorption coefficients of the floor and all vertical surfaces below the test ceiling should not exceed 0.1 at any of the octave band center frequencies given in 7.1.5.1. It is recommended that a structural discontinuity be provided close to the mid-point between the rooms to minimize flanking sound transmission, allowing high values of ceiling attenuation to be measured. The total length of each side wall, including the vibration break (if any), shall be 25 ± 5 ft [7.5 ± 1.5 m] and the width of the room shall be 15.25 ± 0.75 ft [4.65 ± 0.23 m]. The overall height shall be 12 ± 0.5 ft [3.65 ± 0.15 m]. All dimensions shall be measured internally. Fig. 1 shows the major dimensions of the test rooms.

7.1.2 *Separating Wall*— The separating wall shall be of such design that the sound power transmitted through it is at least 10 dB less than the total sound power transmitted through the ceiling specimen. This requirement may be checked by measuring the *D_c* with the calibration ceiling referenced in A1.2, in an interrupted configuration, and an effective gypsum board plenum closure above the partition. All of the separating wall exterior surfaces shall be acoustically reflective. The wall shall be tapered at its upper extremity so that its overall thickness at the top, with the cap installed, is 73 ± 0.1 in. [6 ± 2.5 mm]. The taper angle shall be not less than 45° from the ceiling plane. The height of the wall shall be such that the top exactly meets the lower surface of the ceiling specimen. In the case of interrupted ceiling systems a $50 \pm 2 \pm 0.1$ in. by 3 ± 0.1 in. [2.5 mm by 75 ± 2.5 mm] wooden adaptor cap shall be installed. The length of the adaptor cap shall be identical to the width of the wall. The capping should be designed to simulate a practical header condition typical of the type used for the ceiling being tested. The wall shall be installed near the mid-point of the test room so that two rooms are formed. The two rooms shall not differ in length by more than 15 %.

⁵ The boldface numbers in parentheses refer to the list of references at the end of this standard.

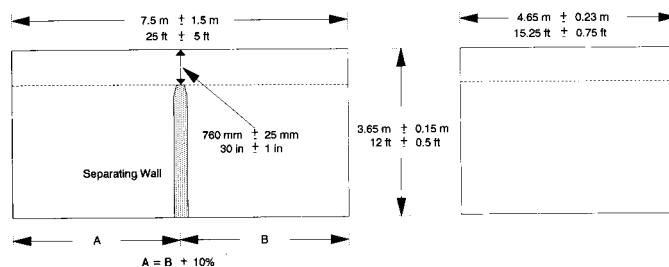

FIG. 1 General Dimensions of the Test Room

NOTE 1—One wall design which has been found to be effective is shown in Fig. 2.

7.1.3 *Plenum Depth*— The plenum depth shall be 30 ± 1 in. [760 ± 25 mm] at the separating wall. At other places within the room, the plenum depth tolerance may be relaxed to ± 2.5 in. [± 64 mm].

7.1.4 *Plenum Width*— The plenum width shall be 14.1 ± 0.1 ft [4.3 ± 0.02 m] at the separating wall (Fig. 3). At other points in the room, the plenum width should be the same as the full room width (see 3.2.5). The restriction in plenum width at the separating wall may be achieved by means of suitable pilasters installed either from floor to roof or from the level of the ceiling underside to the roof.

7.1.5 *Plenum Lining*:

7.1.5.1 All side walls of the plenum shall be lined with suitable sound absorbing material not less than 76 mm (3 in.) thick. This material, shall when tested in accordance with Test Method C423 in a Type A mounting, have random incidence sound absorption coefficients not less than those shown below:

Octave Band Center Frequency, Hz	125	250	500	1000	2000	4000
Absorption Coefficient	0.65	0.80	0.80	0.80	0.80	0.80

NOTE 2—A suitable plenum lining has been found to be a 6-in. thick glass fiber bat with a thin impervious membrane at a depth of 1½ in. below the exposed face.

7.1.5.2 A ledge or shelf, as wide as the plenum lining but not extending beyond the pilaster, may be constructed at ceiling height around the perimeter of both test rooms to support the plenum lining. For the upper surface of the plenum, the sound absorption coefficients measured in accordance with Test Method C423 shall be less than 0.10 at all the above frequencies.

7.1.6 *Diffusers*—A sufficiently diffuse sound field, to meet the precision requirements of 11.3, shall be established. This may be achieved by installing obliquely oriented stationary sound reflecting diffusers, or by the introduction of rotating vane diffusers. It is recommended that three stationary diffusers with a total single side area of at least 85 ft^2 [8 m^2], each diffuser having a minimum width of 2.3 ft [0.7 m], be installed in each room half. Alternately, one rotating vane diffuser having a minimum single side area of 43 ft^2 [4 m^2] and minimum width of 5 ft [1.5 m] may be substituted for each set of three stationary diffusers. Care should be taken to ensure that placement of the diffusers does not shield the ceiling specimen or the sound source. Background noise from rotating vane apparatus together with other noise sources shall be at least 10 dB below the test signal when each are measured in the receiving half of the room.

8. Test Specimen

8.1 Installation of the ceiling specimen should conform with recommended practice for the product. The test ceiling suspension system should be installed in accordance with the provisions of Practice C636. In cases where the normal practice would result in custom fit pieces of ceiling panels smaller than 4 in. [10 cm] in length installed between the supporting ledge on a wall opposite the partition and the adjacent parallel grid member, a filler material that has a higher TL than the specimen may be substituted. Filler materials may only be used at the laboratory end walls farthest from the common partition. No filler materials may be used in grid areas adjacent to the side walls or the common partition.

NOTE 3—Small custom fitted pieces of ceiling panels around the perimeter of the test room may not load the grid properly, allowing excess leakage of sound between the plenum and the test room. Such situations can be avoided along the side walls of the test rooms by shifting the grid system parallel

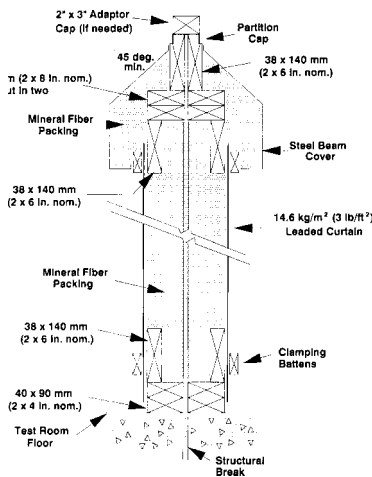

NOTE 1—Except for the adaptor cap, all English units are standard lumber dimensions.

FIG. 2 Vertical Section Through a Partition Found to Satisfy the Requirements of 7.2

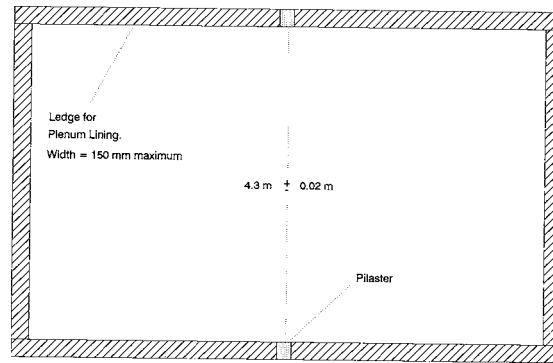

FIG. 3 Horizontal Section Through the Test Rooms at the Ceiling Level

to the partition. Along the end walls of the test rooms it may not be possible to avoid small custom fitted pieces. In this case it may be appropriate to use a filler such as gypsum board to fill these small sections of the ceiling.

8.2 The area of the ceiling system under test shall equal the area formed by the room's length and width, less the following areas:

- 8.2.1 The area of the supporting ledge around the perimeter,
- 8.2.2 The area of the adapter cap when the ceiling is interrupted, and
- 8.2.3 the area of any fillers as described in 8.1.

9. Procedure

9.1 *Test Signal*—The test signal shall satisfy the requirements of Section 6.

9.1.1 The sound pressure level of the test signal shall be sufficient so that the resultant averaged sound pressure level in the receiving room is at least 10 dB above the background noise in any test frequency band.

9.1.2 If more than one sound source is used, each source shall be powered by a separate random noise generator. Multiple drivers in a single loudspeaker enclosure are permitted, provided the drivers are in phase. The maximum volume of each loudspeaker enclosure shall not exceed 1 % of the source room volume.

9.2 *Measurement of Average Sound Pressure Levels \bar{L}_1 and \bar{L}_2* :

9.2.1 One of the two measurement procedures implied by Eq 1 is the determination of the average sound pressure levels \bar{L}_1 and \bar{L}_2 produced in the two rooms by the sound source in the source room. Various systems of data collection and data processing are possible. These include a single microphone placed in sequence at several measurement positions or several microphones switched by a multiplexer. Summing the electrical signal output of several microphones is not permitted. The system adopted shall meet the precision requirements of Section 11. To achieve this end, the points discussed in 9.2.2-9.2.6 should be considered.

9.2.2 *Location of Microphone Positions*—Microphone positions shall be located so as to sample adequately the sound field in each room space, with the following restrictions:

9.2.2.1 The perpendicular distance from any microphone position to any major extended surface shall be no less than 2.5 ft [0.75 m]. This restriction applies to any fixed diffuser, or any possible position of a rotating diffuser.

9.2.2.2 No microphone shall be closer than 5.0 ft [1.5 m] to the sound source, to minimize any effect from the direct sound field.

9.2.2.3 If a microphone on a continuously rotating boom is used to measure the space average sound pressure level, the minimum boom radius shall be 2.5 ft [0.75 m]. If fixed microphone positions are used, they shall be spaced at least 2.5 ft [0.75 m] apart.

9.2.3 *Averaging Time*—For each sampling position, the averaging time shall be sufficient to yield an accurate estimate of the space-time average level. If a rotating diffuser is used, the averaging interval shall be equal in time to at least one rotation of the diffuser.

9.2.4 *Background Noise*—Background noise levels shall routinely be evaluated to ensure that the test signal is in compliance with 9.1.1. Extraneous sound such as flanking transmission, electrical noise in the measurement system, or electrical cross-talk between source and receiving systems is a component of the background noise. Electrical cross-talk should be evaluated by replacing the microphone with an equivalent passive impedance.

9.2.5 *Microphone Calibration*—Each microphone shall be calibrated at regular intervals and a record shall be kept of the dates of such calibration. If multiple microphones are used, their adjusted sensitivities shall be matched within 0.5 dB in any of the specified frequency bands. Calibration over the whole range of test frequencies shall be done periodically, and calibration checks for at least one frequency shall be made prior to each test.

9.2.6 *Determination of Space-Time Average Levels*—Following the procedures of 9.2.2 and 9.2.3, at least two sets of sound pressure data shall be obtained. The space-time average level corresponding to each set is given by

$$\bar{L} = 10 \log \left(\frac{1}{n} \sum_{i=1}^n 10^{L_i/10} \right) \quad (3)$$

where L_i is one set of time-average levels taken at n locations.

NOTE 4—If the range of values L_i is no more than 4 dB, an arithmetic mean value may be used.

9.2.6.1 *Number and Precision of Measurements*—The number of measurements of \bar{L}_1 and \bar{L}_2 shall be sufficient to satisfy the precision requirements of Section 11.

9.2.7 A single microphone continuously moving along a defined traverse may be used instead of stationary microphone positions, provided that the restrictions given in 9.2.2 are met. To estimate the precision of measurements using a moving microphone, divide the traverse path into segments 2.5 ft [0.75 m] apart. Then use the sound pressure measured by averaging over each segment to calculate mean values as in 9.2.6 and to make the precision calculations as in Section 11. Additional information on precision when using a moving microphone may be found in Ref (6).

9.3 Normalization Term:

9.3.1 The normalization term of Eq 2 may be obtained by using the direct method of measuring the receiving room absorption by the sound decay methods described in Test Methods E90 and C423, or from an estimate derived by the steady state method described in 9.3.1.2.

9.3.1.1 If the direct method is used, the normalization term is given by the formula:

$$N_f = 10 \log (A_o/A) \quad (4)$$

where:

A_o = 129 sabin [12 m²], and

A = sound absorption of the receiving room in sabin [m²] measured by the decay method.

The requirements of 9.2.2 regarding the location of microphone positions shall have precedence over the microphone position requirements in Test Methods E90 or C423.

9.3.1.2 The normalization term of Eq 2 may alternately be obtained from estimating the receiving room absorption by a steady-state method. An auxiliary sound source, consisting of a single small loudspeaker in an enclosure, is introduced into a trihedral corner of the receiving room. The auxiliary source is excited with a stable test signal and measurements of the one-third octave band sound pressure levels are measured close to the auxiliary sound source and at distances where the reverberant sound field predominates. The normalization term is then computed from the formula:

$$N_f = \Delta L_r - \Delta L + 10 \log (A_o/A_r) \quad (5)$$

where:

A_o = 129 sabin [12 m²],

ΔL = difference in dB between the direct-field sound pressure level of the auxiliary sound source and the average reverberant field sound pressure level within the receiving room with the test ceiling in place,

ΔL_r = calibration difference (dB) obtained using the procedure of Annex A1 and a calibration ceiling, and

A_r = sound absorption of the receiving room obtained using the procedure of Annex A1.

9.3.2 The normalized ceiling attenuation ($D_{n,c}$) shall be computed for each one-third octave band according to Eq 2.

9.4 *Determination of the Ceiling Attenuation Class (CAC)*—The CAC shall be determined using Classification E413 using values of normalized ceiling attenuation.

10. Report

10.1 Report the following information:

10.1.1 A statement, if true in every respect, that the tests were conducted in accordance with the provisions of this test method.

10.1.2 A full description of the test specimen. The description shall be sufficiently detailed to identify the specimen, at least in terms of the elements that may affect its acoustical performance. The description shall include, but not be limited to; tile or panel size, thickness and weight per unit area, whether the tile or panel perimeter is face rabbeted or otherwise machined, description and designation of additional elements such as luminaires, air handling units, etc., the suspension system including the manufacturer and designation of the grid elements, whether hold-down clips or any other means are used to clamp or seal the ceiling to the grid, whether the ceiling is continuous or interrupted at the partition cap, any overlay or other backing on the plenum side of the test specimen, any acoustical obstruction in the plenum space, such as a plenum barrier, ductwork, etc. A designation and description, including drawings, furnished by the sponsor of the test may be included in the report provided they are attributed to the sponsor.

10.1.3 A full description of the partition, if the test specimen is a combined partition and ceiling installation. The description shall be in equivalent detail to that required for the ceiling.

10.1.4 *Designate* the type of suspension system using the following format:

10.1.4.1 *First Letter*—“C” or “I” for continuous or interrupted at the partition.