



Designation: ~~A962/A962M-11~~ Designation: A962/A962M - 11a

Standard Specification for Common Requirements for Bolting Intended for Use at Any Temperature from Cryogenic to the Creep Range¹

This standard is issued under the fixed designation A962/A962M; the number immediately following the designation indicates the year of original adoption or, in the case of revision, the year of last revision. A number in parentheses indicates the year of last reapproval. A superscript epsilon (ϵ) indicates an editorial change since the last revision or reapproval.

1. Scope*

1.1 This specification covers a group of common requirements that shall apply to carbon, alloy, stainless steel, and nickel alloy bolting under any of the following ASTM Specifications (or under any other ASTM Specifications that invoke this specification or portions thereof):

Title of Specifications	ASTM Designation
Alloy-Steel and Stainless Steel Bolting Materials for High-Temperature Service	A193/A193M
Carbon and Alloy Steel Nuts for Bolts for High Pressure and High-Temperature Service	A194/A194M
Alloy Steel Bolting Materials for Low-Temperature Service	A320/A320M
Alloy-Steel Turbine-Type Bolting Material Specially Heat Treated for High-Temperature Service	A437/A437M
High-Temperature Bolting Materials With Expansion Coefficients Comparable to Austenitic Stainless Steels	A453/A453M
Alloy-Steel Bolting Materials for Special Applications Precipitation-Hardening Bolting Material (UNS N07718) for High Temperature Service	A540/A540M A1014/A1014M

1.2 In case of conflict the requirements of the individual product specification shall prevail over those of this specification.

1.3 Additional requirements may be specified by mutual agreement between the purchaser and supplier.

1.4 Supplementary requirements are provided for use at the option of the purchaser. The supplementary requirements only apply when specified individually by the purchaser in the purchase order or contract.

1.5 This specification is expressed in both inch-pound units and in SI units; however, unless the purchase order or contract specifies the applicable "M" specification designation (SI units) the inch-pound units shall apply. The values stated in either SI units or inch-pound units are to be regarded separately as standard. Within the text, the SI units are shown in brackets. The values stated in each system may not be exact equivalents; therefore, each system shall be used independently of the other. Combining values from the two systems may result in nonconformance with the specification.

2. Referenced Documents

The following documents shall form a part of this specification to the extent specified. The latest issue shall apply unless otherwise specified.

2.1 ASTM Standards:²

A29/A29M [Specification for Steel Bars, Carbon and Alloy, Hot-Wrought, General Requirements for](#)

A193/A193M [Specification for Alloy-Steel and Stainless Steel Bolting for High Temperature or High Pressure Service and Other Special Purpose Applications](#)

A194/A194M [Specification for Carbon and Alloy Steel Nuts for Bolts for High Pressure or High Temperature Service, or Both](#)

A320/A320M [Specification for Alloy-Steel and Stainless Steel Bolting for Low-Temperature Service](#)

A370 [Test Methods and Definitions for Mechanical Testing of Steel Products](#)

A437/A437M [Specification for Stainless and Alloy-Steel Turbine-Type Bolting Specially Heat Treated for High-Temperature Service](#)

¹ This specification is under the jurisdiction of ASTM Committee A01 on Steel, Stainless Steel and Related Alloys and is the direct responsibility of Subcommittee A01.22 on Steel Forgings and Wrought Fittings for Piping Applications and Bolting Materials for Piping and Special Purpose Applications.

Current edition approved ~~May~~Nov. 1, 2011. Published ~~June~~December 2011. Originally approved in 1997. Last previous edition approved in 2010 as A962/A962M-10¹. DOI: 10.1520/A0962_A0962M-11a.

² For referenced ASTM standards, visit the ASTM website, www.astm.org, or contact ASTM Customer Service at service@astm.org. For *Annual Book of ASTM Standards* volume information, refer to the standard's Document Summary page on the ASTM website.

*A Summary of Changes section appears at the end of this standard.

- A453/A453M Specification for High-Temperature Bolting, with Expansion Coefficients Comparable to Austenitic Stainless Steels
- A484/A484M Specification for General Requirements for Stainless Steel Bars, Billets, and Forgings
- A540/A540M Specification for Alloy-Steel Bolting for Special Applications
- A700 Practices for Packaging, Marking, and Loading Methods for Steel Products for Shipment
- A751 Test Methods, Practices, and Terminology for Chemical Analysis of Steel Products
- A788/A788M Specification for Steel Forgings, General Requirements
- A941 Terminology Relating to Steel, Stainless Steel, Related Alloys, and Ferroalloys
- A1014/A1014M Specification for Precipitation-Hardening Bolting (UNS N07718) for High Temperature Service
- E3 Guide for Preparation of Metallographic Specimens
- E381 Method of Macroetch Testing Steel Bars, Billets, Blooms, and Forgings
- E384 Test Method for Knoop and Vickers Hardness of Materials
- E1417 Practice for Liquid Penetrant Testing
- E1444 Practice for Magnetic Particle Testing
- E1916 Guide for Identification of Mixed Lots of Metals
- F788/F788M Specification for Surface Discontinuities of Bolts, Screws, and Studs, Inch and Metric Series
- F2328 Test Method for Determining Decarburization and Carburization in Hardened and Tempered Threaded Steel Bolts, Screws and Studs
- F2328M Test Method for Determining Decarburization and Carburization in Hardened and Tempered Threaded Steel Bolts, Screws and Studs (Metric)
- 2.2 AIAG Standard:³
- AIAG B-5 02.00 Primary Metals Identification Tag Application Standard
- 2.3 ASME Standards:⁴
- B1.1 Screw Threads
- B1.13M Metric Screw Threads – M Profile
- B1.2 Gages and Gaging for Unified Screw Threads
- B1.3M Screw Thread Gaging Systems for Dimensional Acceptability of Metric Screw Threads
- B18.2.1 Square and Hex Bolts and Screws
- B18.2.3.6M Metric Heavy Bolts
- B18.3 Hexagon Socket and Spline Socket Screws
- 2.4 Other Documents:
- ASNT Recommended Practice No. SNT-TC-1A ⁵

3. Terminology

- 3.1 Definitions of Terms Specific to This Standard:
- 3.1.1 *bar*—a solid rolled or forged section that is long in relationship to its cross-sectional dimensions with a relatively constant cross section throughout its length. See Specification A29/A29M for definitions relating to the production of hot wrought and cold finished bars.
- 3.1.2 *bolting*—bolting material (rolled or forged bars or blanks, wire, rod, threaded bar, rotary pierced or extruded seamless tubes, bored bars, or forged hollows from forged or rolled bar segments, to be manufactured into fasteners and fastener bolting components including but not limited to connectors, pins, restraining device components, and shafts) shafts and fasteners themselves (bolts, nuts, screws, studs, and washers).
- 3.1.3 *certifying organization*—the company or association responsible for the conformance and marking of the product to the specification requirements.
- 3.1.4 *class*—a term used to differentiate between different heat treatment conditions or strength levels, or both, often within the same grade but sometimes within the same family of materials. May also apply to work hardened condition or strength level, or both.
- 3.1.5 *grade*—an alloy described individually and identified by its own designation in a table of chemical requirements within any specification.
- 3.1.6 *length, fasteners subject to full size testing*—that portion of the fastener whose body diameter is approximately the same as the nominal thread size.
- 3.1.7 *lot*—unless otherwise specified, a lot shall consist of:
- 3.1.7.1 *bolting, heat treated in batch type furnaces*—all material of the same heat or cast of material, condition, finish, and size subjected to the same heat treatment in one tempering charge and submitted for inspection at the same time.

³ Available from Automotive Industry Action Group (AIAG), 26200 Lahser Rd., Suite 200, Southfield, MI 48033, <http://www.aiag.org>.

⁴ Available from American Society of Mechanical Engineers (ASME), ASME International Headquarters, Three Park Ave., New York, NY 10016-5990, <http://www.asme.org>.

⁵ Available from American Society for Nondestructive Testing (ASNT), P.O. Box 28518, 1711 Arlington Ln., Columbus, OH 43228-0518, <http://www.asnt.org>.

3.1.7.2 *bolting, heat treated in continuous type furnaces*—all material of the same heat or cast of material, condition, finish, and size heat treated without interruption in a continuous type furnace during an eight hour period.

3.1.7.3 *bolting, non heat treated (strain hardened)*—all material of the same heat or cast of material, condition, reduction (cold work), finish and size.

3.1.7.4 *fasteners, machined from bolting material*—all fasteners machined from the same lot of material defined as outlined in either 3.1.7.1 or 3.1.7.2, above without any subsequent heat treatment or hot or cold forming.

3.1.7.5 *fasteners, heat treated in batch type furnaces*—all items produced by any technique (forming, machining, etc.) from the same heat or cast of material, of the same prior condition, the same size, and subjected to the same heat treatment in one tempering charge.

3.1.7.6 *fasteners, heat treated in continuous type furnaces*—all items produced by any technique (forming, machining, etc.) from the same heat or cast of material, of the same prior condition, of the same size, subjected to the same heat treatment in a four hour period and in one tempering charge.

3.1.7.7 *fasteners, non heat treated (strain hardened)*—all fasteners of the same heat or cast of material, condition, reduction (cold work), finish and size.

3.1.7.8 *strain hardened material*—austenitic stainless steel material which has been subjected to cold working sufficient to cause a significant increase in strength.

3.2 *Definitions*—For definitions of other terms used in this specification, refer to Terminology A941.

4. Ordering Information

4.1 It is the purchaser's responsibility to specify in the purchase order all information necessary to purchase the needed material. Examples of such information include, but are not limited, to the following:

4.1.1 Quantity and size,

4.1.2 Product specification number with grade, class, type, as applicable, and including the product specification year date,

4.1.3 Any additional information required by the individual product specification,

4.1.4 Supplementary requirements,

4.1.5 Additional requirements (see 5.2, 5.4, 5.5, 6.1, 7.4, 13.1, 13.3.1, 13.3.3, 13.5.2, 13.6, 15.8, and 19.1).

4.1.6 Additional ordering options provided in the individual product specification, and

4.1.7 Dimensions (diameter, length of point, overall length, finish, shape, threads, etc.).

5. Melting Process

5.1 Unless otherwise specified in the individual product specification, the steel shall be fully killed. Use of the basic oxygen process shall be limited to grades containing less than 6 % chromium.

5.2 If a specific type of melting is required by the purchaser, it shall be stated on the purchase order.

5.3 The primary melting may incorporate separate degassing or refining and may be followed by secondary melting such as electroslag remelting or vacuum remelting. If secondary melting is employed, the heat shall be defined as all of the ingot remelted from a single primary heat.

5.4 Steel may be cast in ingots or may be continuously cast. When steel of different grades is continuously cast identification of the resultant transition material is required. The steel producer shall remove the transition material by an established procedure that positively separates the grades. Should the purchaser deem it necessary to have the transition zone of two heats of the same grade which are continuously cast discarded, the purchaser shall invoke Supplementary Requirement S53.

5.5 *Quality*—The steel producer quality control procedures shall provide sufficient testing of carbon and alloy steels in accordance with Method E381 or other suitable method as agreed upon between the purchaser and the producer to assure the internal quality of the product.

5.5.1 *Ingot Cast Product*—Visual examination of transverse sections shall show no imperfections worse than the macrographs of Method E381 S2-R2-C3 or equivalent as agreed upon.

5.5.2 *Strand Cast Product*—Visual examination of transverse sections in accordance with Method E381 shall reveal none of the conditions shown in macrographs 1-5, 7,12-18 of Plate III. Conditions 6, 8-11 shall not be present to a degree greater than the macrographs of Plates I and II, S2-R2-C3.

6. Materials and Manufacture

6.1 Bars shall be produced in accordance with Specifications A29/A29M or A484/A484M as applicable. Finish (hot or cold, ground, rough turned, drawn, etc.) shall be at the option of the manufacturer unless otherwise specified.

6.2 Fasteners shall be produced in accordance with the product specification.

7. Chemical Composition

7.1 *Chemical Analysis*—Heat or product chemical analysis shall be in accordance with Test Methods, Practices, and Terminology A751.

7.2 *Heat Analysis*—An analysis of each heat of steel shall be made by the steel manufacturer to determine the percentages of those elements specified in the individual product specification. If secondary melting processes are employed, the heat analysis

shall be obtained from one remelted ingot or the product of one remelted ingot of each primary melt. The chemical analysis thus determined shall conform to the requirements of the individual product specification. Product analysis (check analysis) tolerances shall not be applied to heat analysis requirements.

7.3 *Product Analysis*—When performed, by manufacturer, purchaser, end user, and so forth, samples for analysis shall be taken from midway between center and surface of solid parts, midway between inner and outer surfaces of hollow parts, midway between center and surface of full-size prolongations or from broken mechanical test specimens. The chemical composition thus determined shall conform to the limits of the product specification, within the permissible tolerances found in Tables 5 and 6 of Specification A29/A29M and Table 1 of Specification A484/A484M as appropriate for the grade being supplied. When multiple samples are taken from the same lot for product analysis individual elements shall not vary both above and below the specified range.

7.4 For continuous cast materials the requirements of 8.2 or 8.3, as appropriate, of Specification A788/A788M shall be met.

7.5 Steels with intentional additions of lead, bismuth, or tellurium shall not be supplied or used. Steels with intentional additions of selenium may only be supplied or used when specifically called out in the product specification.

7.6 The starting material shall not contain any unspecified elements, other than nitrogen in austenitic stainless steels, for the ordered grade(s) to the extent that it then conforms to the requirements of another grade for which that element is a specified element having a required minimum content.

8. Mechanical Properties

8.1 *Method of Mechanical Tests*—All tests shall be conducted in accordance with Test Methods and Definitions A370 unless otherwise specified.

8.2 For the purpose of determining conformance to the product specification requirements, specimens shall be obtained from the production material, or, in the case of forgings, from separately forged test blanks prepared from the stock used to make the finished product. Heat treatment shall be completed prior to removal of material for mechanical testing.

8.3 If separately forged test blanks are used, they shall be of the same heat of steel, be subjected to substantially the same reduction and working as the production forging they represent, be heat treated in the same furnace charge and under the same conditions as the production forging, and be of the same nominal thickness as the maximum heat treated thickness of the production forging.

8.4 *Bars*—Tension and impact tests representing bar stock shall be taken in accordance with the requirements of Annex A1 of Test Methods and Definitions A370. Impact tests are not required on bars $\frac{1}{2}$ in. and under in diameter.

8.5 *Fasteners, Machined from Heat Treated Bar*—Mechanical properties of fasteners machined from heat treated bar shall be represented by the tests run on the bar in accordance with 8.4.

8.6 *Fasteners, All Classes—Produced by other methods*—When fasteners have been produced by forming, when they have been subjected to heat treatment, or when the nominal thread size falls into a different diameter range than that of the starting bar as shown in the applicable specifications, then tests shall be run on material taken from those fasteners.

8.6.1 Tension test specimens taken from finished fasteners shall be machined to the form and dimensions and from the positions shown in Annex A3 of Test Methods and Definitions A370. Impact tests are not required on material from externally threaded fasteners when the thread diameter is $\frac{1}{2}$ in. and under.

9. Hardness Requirements

9.1 The material shall conform to the hardness requirements prescribed in the product specification. Hardness testing shall be performed in accordance with Test Methods and Definitions A370.

9.2 Tensile tests prevail over hardness tests in the event a conflict exists relative to minimum strength unless otherwise specified in the product specification.

10. Tensile Requirements

10.1 *Bars and Specimens Machined From Fasteners*—The material shall conform to the tensile property requirements prescribed in the product specification.

10.1.1 When the dimensions of the material to be tested will permit, the tension test specimens shall be machined to the form and dimensions of the standard 2-in. [50-mm] gage length tension test specimen described in Test Methods and Definitions A370.

10.1.2 When the dimensions of the material to be tested do not permit full size samples, small size specimens meeting the requirements of Test Methods and Definitions A370 shall be used.

11. Proof Load and Cone Proof Requirements

11.1 *Proof Load Test*—Nuts shall be assembled on a threaded mandrel or a test bolt as illustrated in Fig. 1(a) Tension Method or (b) Compression Method. The minimum proof load required by the product specification shall be applied using a free running cross head speed of 1.0 in [25 mm] per minute maximum and shall be held for at least 10 s. The nut shall resist this load without stripping or rupture, and shall be removable by hand, without use of tooling, after the load is released. A wrench may be used to loosen the nut one-half turn maximum to start it in motion. The test shall be discarded if the threads of the mandrel or test bolt are damaged during the test.

11.1.1 Mandrels shall have a hardness of 45 HRC minimum with threads of the appropriate series and conforming to the requirements of ASME B1.1 Class 3A or ASME B1.13M tolerance 4H except that the maximum major diameter shall be the

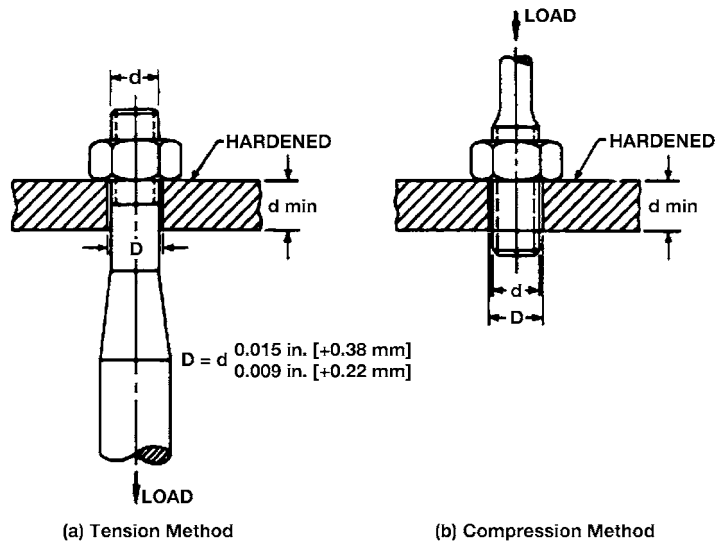

FIG. 1 Proof Load Testing—Nuts

minimum major diameter plus 0.25 times the major diameter tolerance.

11.1.2 The test bolt shall have threads appropriate to the standard specified for the nut being tested and shall have a yield strength in excess of the specified proof load of the nut being tested.

11.1.3 The mandrel/tension method shall be used when arbitration is required.

11.2 *Cone Proof Load Test*—This test is performed when visible surface discontinuities become a matter of issue. The test uses a conical washer and threaded mandrel to determine the load-carrying ability of hardened steel nuts through 1½ in. [36 mm] in diameter assembled as shown in Fig. 2. The minimum cone proof load required by the product specification shall be applied using a free running cross head speed of 0.12 in. [3 mm] per minute maximum and shall be held for at least 10 s. The nut shall support its specified cone proof load without stripping or rupture.

11.2.1 Mandrels shall conform to the requirements of 11.1.1.

11.2.2 Conical washers shall have a hardness of 57 HRC minimum and a hole diameter equivalent to the nominal diameter of the mandrel +0.002, -0.000 in. [+0.05 and -0.00 mm].

11.2.3 The contact point of the cone shall be sharp for nut sizes ½ in. [12 mm] or less. For sizes over ½ in. [12 mm], the point shall be flat and 0.015 ± 0.001 in. [0.38 + 0.03 mm] in width.

11.2.4 Cone proof loads may be determined as shown in Tables 1 and 2 when they are not specified in the product specification.

12. Impact Requirements

12.1 The material shall conform to the impact requirements prescribed in the product specification.

12.2 Sampling for impact testing shall conform to the product specification.

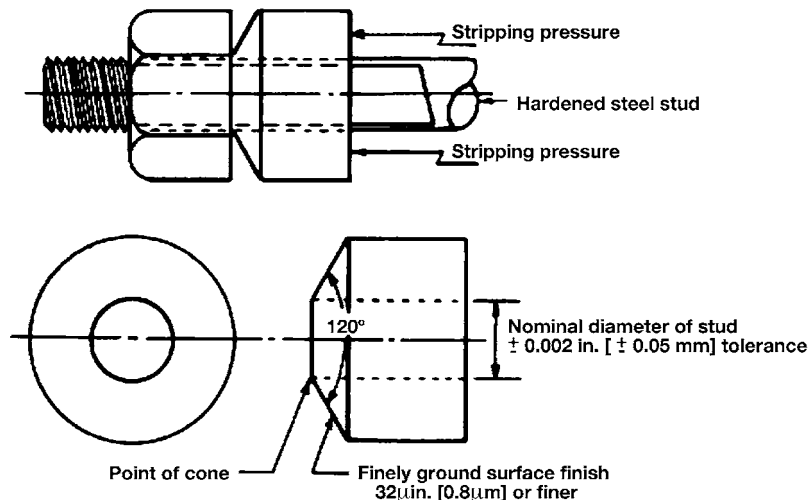

FIG. 2 Cone-Proof Test

TABLE 1 Cone Proof Load Using 120° Hardened Steel Cone—Inch^A

Nominal Threads Size, in.	Stress per inch Area, in. ²	Cone Proof Load, lbf					
		Based on Proof Stress, psi, Shown in Column Header Below					
		120 000	130 000	135 000	150 000	175 000	
¼	28	0.0364	4050	4375	4550	5050	5900
¼	20	0.0318	3525	3825	3975	4400	5150
⅝	24	0.0580	6300	6825	7100	7875	9200
⅝	18	0.0524	5700	6175	6400	7125	8300
¾	24	0.0878	9350	10 125	10 525	11 700	13 625
¾	16	0.0775	8250	8950	9300	10 300	12 050
⅞	20	0.1187	12 350	13 400	13 900	15 450	18 050
⅞	14	0.1063	11 100	12 000	12 450	13 850	16 150
1	20	0.1599	16 300	17 650	18 350	20 400	23 800
1	13	0.1419	14 500	15 700	16 300	18 100	21 100
1 ⅛	18	0.203	20 200	21 900	22 800	25 300	29 500
1 ⅛	12	0.182	18 200	19 700	20 400	22 700	26 500
1 ¼	18	0.256	25 000	27 000	28 100	31 200	36 400
1 ¼	11	0.226	22 000	23 900	24 800	27 500	32 100
1 ½	16	0.373	34 700	37 600	39 000	43 400	50 600
1 ½	10	0.334	31 000	33 600	35 000	38 800	45 200
1 ¾	14	0.509	45 000	48 800	50 600	56 400	65 600
1 ¾	9	0.462	40 800	44 200	46 000	51 200	59 600
2	12	0.663	55 600	60 400	62 600	69 600	81 200
2	8	0.606	51 000	55 200	57 200	63 600	74 200
2 ⅛	12	0.856	68 000	73 800	76 600	85 000	99 200
2 ⅛	8	0.790	62 800	68 000	70 600	78 600	91 600
2 ¼	7	0.763	60 750	65 750	68 250	75 750	88 500
2 ¼	12	1.073	80 500	87 250	90 500	100 500	117 250
2 ½	8	1.000	75 000	81 250	84 250	93 750	109 250
2 ¾	7	0.969	72 750	78 750	81 750	90 750	106 000
3	12	1.315	92 750	100 500	104 250	116 000	135 250
3	8	1.233	87 000	94 250	98 000	108 750	126 750
3 ⅛	6	1.155	81 500	88 250	91 500	101 750	118 750
3 ½	12	1.581	104 250	113 000	117 500	130 500	152 250
3 ½	8	1.492	98 500	106 750	110 750	123 000	143 500
4	6	1.405	92 750	100 500	104 250	116 000	135 250

^ABased upon the following equation (this equation should not be used for extrapolating values beyond the size ranges listed in this table) and rounded to nearest ½ ksi equivalent:

$$CPL = (1 - 0.30D) \times f \times As \text{ A0962_A0962M-11A_1}$$

where:

- CPL = cone stripping proof load, lbf.,
D = nominal diameter of nut, in.,
f = minimum proof stress of nut, psi.,
As = tensile stress area of nut, in² = 0.7854 [D - 0.9743/n]², and
n = threads per inch.

12.3 The impact test specimen shall have the form and dimensions shown in Fig. 10 of Test Methods and Definitions A370 for the Charpy V-notch specimen, Type A. The longitudinal axis of the specimen shall be parallel to the direction of rolling or, in the case of forgings, to the longest axis of the component the test bar represents. The notch shall be located on the test specimen surface which most closely approaches a radial direction. The base of the notch shall be as nearly as practicable perpendicular to the longest axis of the component.

13. Workmanship, Finish, and Appearance

13.1 The parts shall conform to the dimensions, tolerances and finish as specified on the purchaser's order or in the individual product specification.

13.2 *Bars*—Bars shall meet the dimensional requirements of Specifications A29/A29M or A484/A484M as applicable.

13.3 *Bolts, Screws, Studs, and Stud Bolts*—Fastener points shall be flat and chamfered or rounded at the option of the manufacturer. The length of the point on studs and stud bolts shall be not less than one nor more than two complete threads as measured from the extreme end parallel to the axis. Length of studs and stud bolts shall be measured from first thread to first thread. Bolts, studs, and bolting material shall be capable of passing inspection in accordance with Specification F788/F788M.

13.3.1 *Hex Bolts*—Unless otherwise specified in the purchase order heads shall be in accordance with the dimensions of ASME B18.2.1 or B18.2.3.6M and the Heavy Hex screw series, should be used, except the maximum body diameter and radius of fillets may be the same as for the heavy hex bolt series. The body diameter and head fillet radius for sizes of heavy hex cap screws and bolts that are not shown in their respective tables in the ASME specifications may be that shown in the corresponding hex cap screw and bolt tables respectively.