



Designation: D1586 – 11

# Standard Test Method for Standard Penetration Test (SPT) and Split-Barrel Sampling of Soils<sup>1</sup>

This standard is issued under the fixed designation D1586; the number immediately following the designation indicates the year of original adoption or, in the case of revision, the year of last revision. A number in parentheses indicates the year of last reapproval. A superscript epsilon ( $\epsilon$ ) indicates an editorial change since the last revision or reapproval.

*This standard has been approved for use by agencies of the U.S. Department of Defense.*

## 1. Scope\*

1.1 This test method describes the procedure, generally known as the Standard Penetration Test (SPT), for driving a split-barrel sampler to obtain a representative disturbed soil sample for identification purposes, and measure the resistance of the soil to penetration of the sampler. Another method (Test Method [D3550](#)) to drive a split-barrel sampler to obtain a representative soil sample is available but the hammer energy is not standardized.

1.2 Practice [D6066](#) gives a guide to determining the normalized penetration resistance of sands for energy adjustments of N-value to a constant energy level for evaluating liquefaction potential.

1.3 Test results and identification information are used to estimate subsurface conditions for foundation design.

1.4 Penetration resistance testing is typically performed at 5-ft depth intervals or when a significant change of materials is observed during drilling, unless otherwise specified.

1.5 This test method is limited to use in nonlithified soils and soils whose maximum particle size is approximately less than one-half of the sampler diameter.

1.6 This test method involves use of rotary drilling equipment (Guide [D5783](#), Practice [D6151](#)). Other drilling and sampling procedures (Guide [D6286](#), Guide [D6169](#)) are available and may be more appropriate. Considerations for hand driving or shallow sampling without boreholes are not addressed. Subsurface investigations should be recorded in accordance with Practice [D5434](#). Samples should be preserved

and transported in accordance with Practice [D4220](#) using Group B. Soil samples should be identified by group name and symbol in accordance with Practice [D2488](#).

1.7 All observed and calculated values shall conform to the guidelines for significant digits and rounding established in Practice [D6026](#), unless superseded by this test method.

1.8 The values stated in inch-pound units are to be regarded as standard, except as noted below. The values given in parentheses are mathematical conversions to SI units, which are provided for information only and are not considered standard.

1.8.1 The gravitational system of inch-pound units is used when dealing with inch-pound units. In this system, the pound (lbf) represents a unit of force (weight), while the unit for mass is slugs.

1.9 Penetration resistance measurements often will involve safety planning, administration, and documentation. This test method does not purport to address all aspects of exploration and site safety. *This standard does not purport to address all of the safety concerns, if any, associated with its use. It is the responsibility of the user of this standard to establish appropriate safety and health practices and determine the applicability of regulatory limitations prior to use.* Performance of the test usually involves use of a drill rig; therefore, safety requirements as outlined in applicable safety standards (for example, OSHA regulations,<sup>2</sup> NDA Drilling Safety Guide,<sup>3</sup> drilling safety manuals, and other applicable state and local regulations) must be observed.

1.10 *This international standard was developed in accordance with internationally recognized principles on standardization established in the Decision on Principles for the*

<sup>1</sup> This method is under the jurisdiction of ASTM Committee [D18](#) on Soil and Rock and is the direct responsibility of Subcommittee [D18.02](#) on Sampling and Related Field Testing for Soil Evaluations.

Current edition approved Nov. 1, 2011. Published December 2011. Originally approved in 1958. Last previous edition approved in 2008 as D1586 – 08a. DOI: 10.1520/D1586-11.

<sup>2</sup> Available from Occupational Safety and Health Administration (OSHA), 200 Constitution Ave., NW, Washington, DC 20210, <http://www.osha.gov>.

<sup>3</sup> Available from the National Drilling Association, 3511 Center Rd., Suite 8, Brunswick, OH 44212, <http://www.nda4u.com>.

\*A Summary of Changes section appears at the end of this standard

*Development of International Standards, Guides and Recommendations issued by the World Trade Organization Technical Barriers to Trade (TBT) Committee.*

## 2. Referenced Documents

### 2.1 ASTM Standards:<sup>4</sup>

- D653** Terminology Relating to Soil, Rock, and Contained Fluids
- D854** Test Methods for Specific Gravity of Soil Solids by Water Pycnometer
- D1587** Practice for Thin-Walled Tube Sampling of Fine-Grained Soils for Geotechnical Purposes
- D2216** Test Methods for Laboratory Determination of Water (Moisture) Content of Soil and Rock by Mass
- D2487** Practice for Classification of Soils for Engineering Purposes (Unified Soil Classification System)
- D2488** Practice for Description and Identification of Soils (Visual-Manual Procedure)
- D3550** Practice for Thick Wall, Ring-Lined, Split Barrel, Drive Sampling of Soils
- D3740** Practice for Minimum Requirements for Agencies Engaged in Testing and/or Inspection of Soil and Rock as Used in Engineering Design and Construction
- D4220** Practices for Preserving and Transporting Soil Samples
- D4633** Test Method for Energy Measurement for Dynamic Penetrometers
- D5434** Guide for Field Logging of Subsurface Explorations of Soil and Rock
- D5783** Guide for Use of Direct Rotary Drilling with Water-Based Drilling Fluid for Geoenvironmental Exploration and the Installation of Subsurface Water-Quality Monitoring Devices
- D6026** Practice for Using Significant Digits in Geotechnical Data
- D6066** Practice for Determining the Normalized Penetration Resistance of Sands for Evaluation of Liquefaction Potential
- D6151** Practice for Using Hollow-Stem Augers for Geotechnical Exploration and Soil Sampling
- D6169** Guide for Selection of Soil and Rock Sampling Devices Used With Drill Rigs for Environmental Investigations
- D6286** Guide for Selection of Drilling Methods for Environmental Site Characterization
- D6913** Test Methods for Particle-Size Distribution (Gradation) of Soils Using Sieve Analysis

## 3. Terminology

### 3.1 Definitions:

3.1.1 Definitions of terms included in Terminology **D653** specific to this practice are:

3.1.2 *cathead*, *n*—the rotating drum or windlass in the rope-cathead lift system around which the operator wraps a

rope to lift and drop the hammer by successively tightening and loosening the rope turns around the drum.

3.1.3 *drill rods*, *n*—rods used to transmit downward force and torque to the drill bit while drilling a borehole.

3.1.4 *N-value*, *n*—the blow count representation of the penetration resistance of the soil. The *N-value*, reported in blows per foot, equals the sum of the number of blows (*N*) required to drive the sampler over the depth interval of 6 to 18 in. (150 to 450 mm) (see **7.3**).

3.1.5 *Standard Penetration Test (SPT)*, *n*—a test process in the bottom of the borehole where a split-barrel sampler having an inside diameter of either 1-1/2-in. (38.1 mm) or 1-3/8-in. (34.9 mm) (see **Note 2**) is driven a given distance of 1.0 ft (0.30 m) after a seating interval of 0.5 ft (0.15 m) using a hammer weighing approximately 140-lbf (623-N) falling  $30 \pm 1.0$  in. ( $0.76 \text{ m} \pm 0.030 \text{ m}$ ) for each hammer blow.

### 3.2 Definitions of Terms Specific to This Standard:

3.2.1 *anvil*, *n*—that portion of the drive-weight assembly which the hammer strikes and through which the hammer energy passes into the drill rods.

3.2.2 *drive weight assembly*, *n*—an assembly that consists of the hammer, anvil, hammer fall guide system, drill rod attachment system, and any hammer drop system hoisting attachments.

3.2.3 *hammer*, *n*—that portion of the drive-weight assembly consisting of the  $140 \pm 2$  lbf ( $623 \pm 9$  N) impact weight which is successively lifted and dropped to provide the energy that accomplishes the sampling and penetration.

3.2.4 *hammer drop system*, *n*—that portion of the drive-weight assembly by which the operator or automatic system accomplishes the lifting and dropping of the hammer to produce the blow.

3.2.5 *hammer fall guide*, *n*—that part of the drive-weight assembly used to guide the fall of the hammer.

3.2.6 *number of rope turns*, *n*—the total contact angle between the rope and the cathead at the beginning of the operator's rope slackening to drop the hammer, divided by  $360^\circ$  (see **Fig. 1**).

3.2.7 *sampling rods*, *n*—rods that connect the drive-weight assembly to the sampler. Drill rods are often used for this purpose.

## 4. Significance and Use

4.1 This test method provides a disturbed soil sample for moisture content determination, for identification and classification (Practices **D2487** and **D2488**) purposes, and for laboratory tests appropriate for soil obtained from a sampler that will produce large shear strain disturbance in the sample such as Test Methods **D854**, **D2216**, and **D6913**. Soil deposits containing gravels, cobbles, or boulders typically result in penetration refusal and damage to the equipment.

4.2 This test method provides a disturbed soil sample for moisture content determination and laboratory identification. Sample quality is generally not suitable for advanced laboratory testing for engineering properties. The process of driving

<sup>4</sup> For referenced ASTM standards, visit the ASTM website, [www.astm.org](http://www.astm.org), or contact ASTM Customer Service at [service@astm.org](mailto:service@astm.org). For *Annual Book of ASTM Standards* volume information, refer to the standard's Document Summary page on the ASTM website.

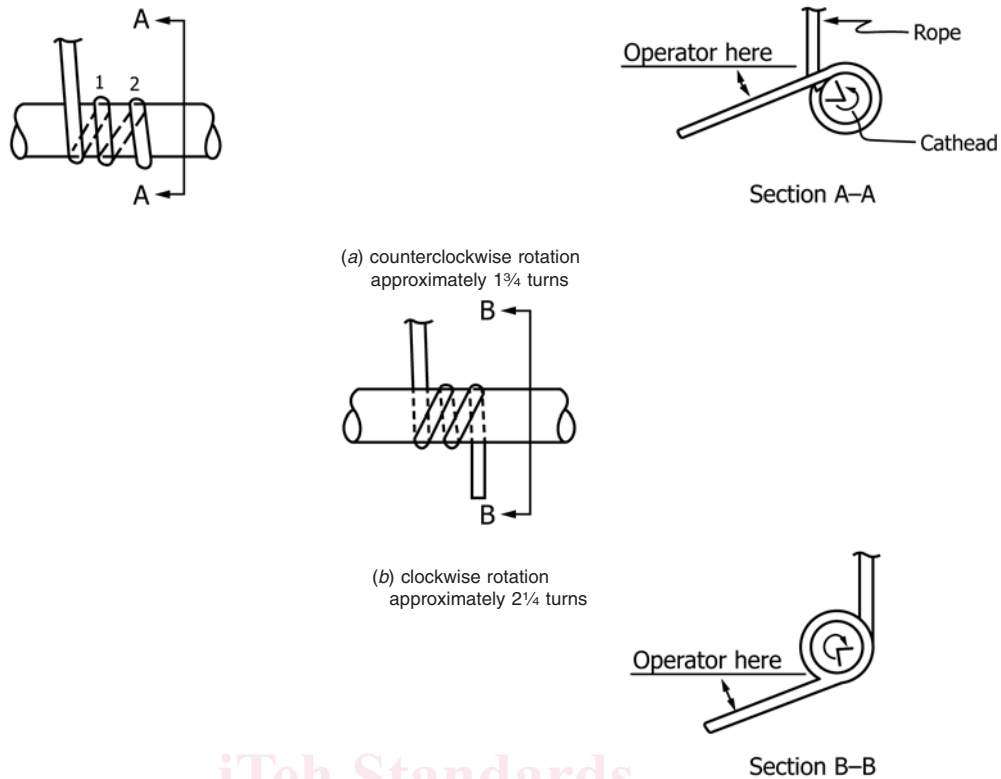

FIG. 1 Definitions of the Number of Rope Turns and the Angle for (a) Counterclockwise Rotation and (b) Clockwise Rotation of the Cat-head

the sampler will cause disturbance of the soil and change the engineering properties. Use of the thin wall tube sampler (Practice D1587) may result in less disturbance in soft soils. Coring techniques may result in less disturbance than SPT sampling for harder soils, but it is not always the case, that is, some cemented soils may become loosened by water action during coring; see Practice D6151, and Guide D6169.

4.3 This test method is used extensively in a great variety of geotechnical exploration projects. Many local correlations and widely published correlations which relate blow count, or  $N$ -value, and the engineering behavior of earthworks and foundations are available. For evaluating the liquefaction potential of sands during an earthquake event, the  $N$ -value should be normalized to a standard overburden stress level. Practice D6066 provides methods to obtain a record of normalized resistance of sands to the penetration of a standard sampler driven by a standard energy. The penetration resistance is adjusted to drill rod energy ratio of 60 % by using a hammer system with either an estimated energy delivery or directly measuring drill rod stress wave energy using Test Method D4633.

NOTE 1—The reliability of data and interpretations generated by this practice is dependent on the competence of the personnel performing it and the suitability of the equipment and facilities used. Agencies that meet the criteria of Practice D3740 generally are considered capable of competent testing. Users of this practice are cautioned that compliance with Practice D3740 does not assure reliable testing. Reliable testing

depends on several factors and Practice D3740 provides a means of evaluating some of these factors. Practice D3740 was developed for agencies engaged in the testing, inspection, or both, of soils and rock. As such, it is not totally applicable to agencies performing this practice. Users of this test method should recognize that the framework of Practice D3740 is appropriate for evaluating the quality of an agency performing this test method. Currently, there is no known qualifying national authority that inspects agencies that perform this test method.

## 5. Apparatus

5.1 *Drilling Equipment*—Any drilling equipment that provides at the time of sampling a suitable borehole before insertion of the sampler and ensures that the penetration test is performed on intact soil shall be acceptable. The following pieces of equipment have proven to be suitable for advancing a borehole in some subsurface conditions:

5.1.1 *Drag, Chopping, and Fishtail Bits*, less than  $6\frac{1}{2}$  in. (165 mm) and greater than  $2\frac{1}{4}$  in. (57 mm) in diameter may be used in conjunction with open-hole rotary drilling or casing-advancement drilling methods. To avoid disturbance of the underlying soil, bottom discharge bits are not permitted; only side discharge bits are permitted.

5.1.2 *Roller-Cone Bits*, less than  $6\frac{1}{2}$  in. (165 mm) and greater than  $2\frac{1}{4}$  in. (57 mm) in diameter may be used in conjunction with open-hole rotary drilling or casing-advancement drilling methods if the drilling fluid discharge is deflected.

5.1.3 *Hollow-Stem Continuous Flight Augers*, with or without a center bit assembly, may be used to drill the borehole. The inside diameter of the hollow-stem augers shall be less than 6½ in. (165 mm) and not less than 2¼ in. (57 mm).

5.1.4 *Solid, Continuous Flight, Bucket and Hand Augers*, less than 6½ in. (165 mm) and not less than 2¼ in. (57 mm) in diameter may be used if the soil on the side of the borehole does not cave onto the sampler or sampling rods during sampling.

5.2 *Sampling Rods*—Flush-joint steel drill rods shall be used to connect the split-barrel sampler to the drive-weight assembly. The sampling rod shall have a stiffness (moment of inertia) equal to or greater than that of parallel wall “A” rod (a steel rod that has an outside diameter of 1-5/8 in. (41.3 mm) and an inside diameter of 1-1/8 in. (28.5 mm)).

5.3 *Split-Barrel Sampler*—The standard sampler dimensions are shown in Fig. 2. The sampler has an outside diameter of 2.00 in. (50.8 mm). The inside diameter of the of the split-barrel (dimension D in Fig. 2) can be either 1½-in. (38.1 mm) or 1⅜-in. (34.9 mm) (see Note 2). A 16-gauge liner can be used inside the 1½-in. (38.1 mm) split barrel sampler. The driving shoe shall be of hardened steel and shall be replaced or repaired when it becomes dented or distorted. The penetrating end of the drive shoe may be slightly rounded. The split-barrel sampler must be equipped with a ball check and vent. Metal or plastic baskets may be used to retain soil samples.

NOTE 2—Both theory and available test data suggest that *N*-values may differ as much as 10 to 30 % between a constant inside diameter sampler and upset wall sampler. If it is necessary to correct for the upset wall sampler refer to Practice D6066. In North America, it is now common

practice to use an upset wall sampler with an inside diameter of 1½ in. At one time, liners were used but practice evolved to use the upset wall sampler without liners. Use of an upset wall sampler allows for use of retainers if needed, reduces inside friction, and improves recovery. Many other countries still use a constant ID split-barrel sampler, which was the original standard and still acceptable within this standard.

5.4 *Drive-Weight Assembly:*

5.4.1 *Hammer and Anvil*—The hammer shall weigh 140 ± 2 lbf (623 ± 9 N) and shall be a rigid metallic mass. The hammer shall strike the anvil and make steel on steel contact when it is dropped. A hammer fall guide permitting an unimpeded fall shall be used. Fig. 3 shows a schematic of such hammers. Hammers used with the cathead and rope method shall have an unimpeded over lift capacity of at least 4 in. (100 mm). For safety reasons, the use of a hammer assembly with an internal anvil is encouraged as shown in Fig. 3. The total mass of the hammer assembly bearing on the drill rods should not be more than 250 ± 10 lbf (113 ± 5 kg).

NOTE 3—It is suggested that the hammer fall guide be permanently marked to enable the operator or inspector to judge the hammer drop height.

5.4.2 *Hammer Drop System*—Rope-cathead, trip, semi-automatic or automatic hammer drop systems may be used, providing the lifting apparatus will not cause penetration of the sampler while re-engaging and lifting the hammer.

5.5 *Accessory Equipment*—Accessories such as labels, sample containers, data sheets, and groundwater level measuring devices shall be provided in accordance with the requirements of the project and other ASTM standards.

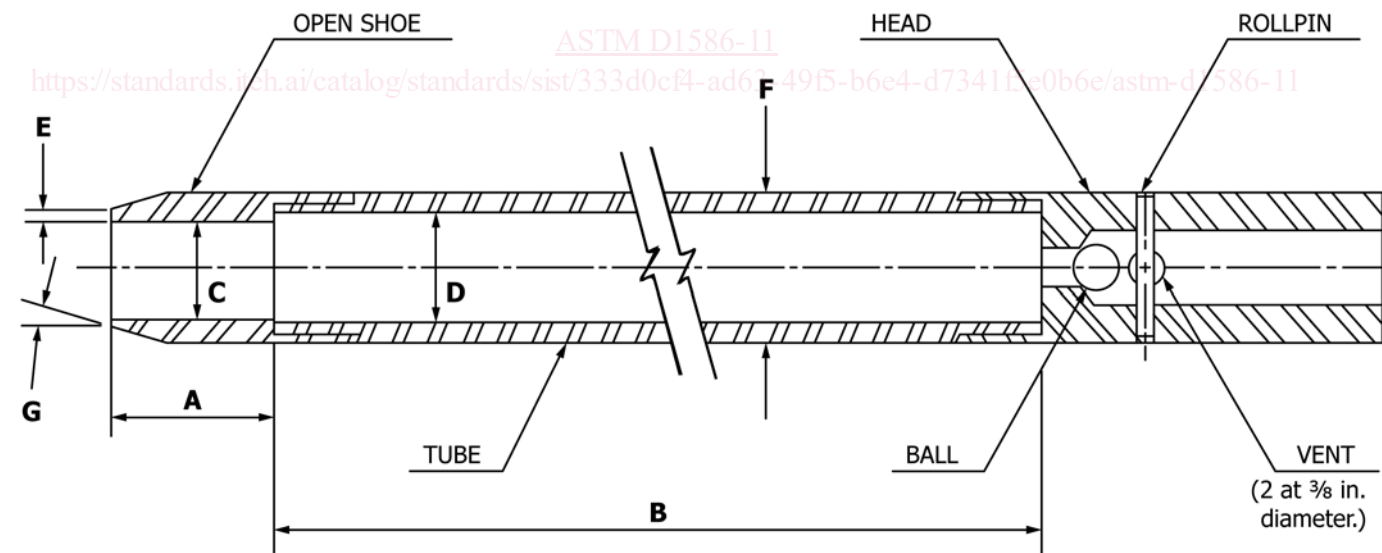

- A = 1.0 to 2.0 in. (25 to 50 mm)
- B = 18.0 to 30.0 in. (0.457 to 0.762 m)
- C = 1.375 ± 0.005 in. (34.93 ± 0.13 mm)
- D = 1.50 ± 0.05 - 0.00 in. (38.1 ± 1.3 - 0.0 mm)
- E = 0.10 ± 0.02 in. (2.54 ± 0.25 mm)
- F = 2.00 ± 0.05 - 0.00 in. (50.8 ± 1.3 - 0.0 mm)
- G = 16.0° to 23.0°

FIG. 2 Split-Barrel Sampler