**Fasteners — Hexalobular socket
countersunk flat head screws
(common head style) with reduced
loadability**

*Fixations — Vis à tête fraisée (tête commune) à six lobes internes à
capacité de charge réduite*

iTeh STANDARD PREVIEW
(standards.iteh.ai)

ISO 14581:2022

<https://standards.iteh.ai/catalog/standards/sist/d166b5e1-c09c-4bed-9681-e9a10c36ea2f/iso-14581-2022>



iTeh STANDARD PREVIEW
(standards.iteh.ai)

ISO 14581:2022

<https://standards.iteh.ai/catalog/standards/sist/d166b5e1-c09c-4bed-9681-e9a10c36ea2f/iso-14581-2022>



COPYRIGHT PROTECTED DOCUMENT

© ISO 2022

All rights reserved. Unless otherwise specified, or required in the context of its implementation, no part of this publication may be reproduced or utilized otherwise in any form or by any means, electronic or mechanical, including photocopying, or posting on the internet or an intranet, without prior written permission. Permission can be requested from either ISO at the address below or ISO's member body in the country of the requester.

ISO copyright office
CP 401 • Ch. de Blandonnet 8
CH-1214 Vernier, Geneva
Phone: +41 22 749 01 11
Email: copyright@iso.org
Website: www.iso.org

Published in Switzerland

Contents

	Page
Foreword.....	iv
1 Scope	1
2 Normative references	1
3 Terms and definitions	2
4 Dimensions and gauging of the head	2
4.1 Dimensions.....	2
4.2 Gauging of head.....	7
5 Requirements and reference International Standards	7
6 Marking and labelling	8
6.1 Marking on product.....	8
6.2 Labelling on package.....	8
7 Designation	9
Annex A (informative) Minimum ultimate tensile loads for screws M2 and M2,5 with full loadability	10
Bibliography	11

iTeh STANDARD PREVIEW
(standards.iteh.ai)

ISO 14581:2022

<https://standards.iteh.ai/catalog/standards/sist/d166b5e1-c09c-4bed-9681-e9a10c36ea2f/iso-14581-2022>

Foreword

ISO (the International Organization for Standardization) is a worldwide federation of national standards bodies (ISO member bodies). The work of preparing International Standards is normally carried out through ISO technical committees. Each member body interested in a subject for which a technical committee has been established has the right to be represented on that committee. International organizations, governmental and non-governmental, in liaison with ISO, also take part in the work. ISO collaborates closely with the International Electrotechnical Commission (IEC) on all matters of electrotechnical standardization.

The procedures used to develop this document and those intended for its further maintenance are described in the ISO/IEC Directives, Part 1. In particular, the different approval criteria needed for the different types of ISO documents should be noted. This document was drafted in accordance with the editorial rules of the ISO/IEC Directives, Part 2 (see www.iso.org/directives).

Attention is drawn to the possibility that some of the elements of this document may be the subject of patent rights. ISO shall not be held responsible for identifying any or all such patent rights. Details of any patent rights identified during the development of the document will be in the Introduction and/or on the ISO list of patent declarations received (see www.iso.org/patents).

Any trade name used in this document is information given for the convenience of users and does not constitute an endorsement.

For an explanation of the voluntary nature of standards, the meaning of ISO specific terms and expressions related to conformity assessment, as well as information about ISO's adherence to the World Trade Organization (WTO) principles in the Technical Barriers to Trade (TBT), see www.iso.org/iso/foreword.html.

This document was prepared by Technical Committee ISO/TC 2, *Fasteners*, Subcommittee SC 11, *Fasteners with metric external thread*, in collaboration with the European Committee for Standardization (CEN) Technical Committee CEN/TC 185, *Fasteners*, in accordance with the Agreement on technical cooperation between ISO and CEN (Vienna Agreement).

This second edition cancels and replaces the first edition (ISO 14581:2013), which has been technically revised.

The main changes are as follows:

- the whole standard (including title) has been improved to clearly point out that these hexalobular socket countersunk flat head screws with common head style have reduced loadability because of their head design (head dimensions and penetration of the hexalobular socket);
- for M2 to M4, partially threaded screws without underhead reinforcement (formerly designated as “shoulder”) and normative reference to ISO 3508 for x_{\max} (see figure footnote e) have been added (see [Figure 1 b](#));
- for M5 to M10, underhead reinforcement has been modified from a radius to a conical shape as adjustment to manufacturing conditions and normative reference to ISO 3508 for x_{\max} (see figure footnote e) has been added (see [Figure 2 b](#));
- detailed head configuration has been added (see [Figure 3](#));
- shank diameter d_s has been added in [Table 1](#);
- minimum head height k_{\min} has been added as reference dimension in [Table 1](#);
- radius r has been specified for all head configurations (see [Figures 1 and 2](#)), and r_{\min} has been added in [Table 1](#);
- shortest standard lengths l_{nom} have been increased in [Table 1](#);

- calculations for M2 and M2,5 have been added in [Table 3](#) for steel screws; as their minimum ultimate tensile loads for full loadability are not specified in ISO 898-1 and ISO 3506-1, they have been calculated with the same formulae accordingly (see [Table A.1](#), [Annex A](#));
- the minimum ultimate tensile loads were recalculated and have been changed to more precise values for steel screws with property classes 4.8 (M3 and M6), 8.8 (M5), and for stainless steel screws with property classes 50 (M3, M6 and M8) and 70 (M3, M6, M8 and M10); see [Table 3](#);
- property class 10.9 has been added (see [Table 2](#));
- specifications for labelling have been added as new [subclause 6.2](#);
- reference to ISO 15065 for countersinks has been added.

Any feedback or questions on this document should be directed to the user's national standards body. A complete listing of these bodies can be found at www.iso.org/members.html.

iTeh STANDARD PREVIEW (standards.iteh.ai)

[ISO 14581:2022](#)

<https://standards.iteh.ai/catalog/standards/sist/d166b5e1-c09c-4bed-9681-e9a10c36ea2f/iso-14581-2022>

Fasteners — Hexalobular socket countersunk flat head screws (common head style) with reduced loadability

1 Scope

This document specifies the characteristics of hexalobular socket countersunk flat head screws with reduced loadability due to head design, in steel and stainless steel, with metric coarse pitch threads M2 to M10, and with product grade A.

If in certain cases other specifications are requested, stainless steel grades can be selected from ISO 3506-1, and dimensional options from ISO 888 or ISO 4753.

NOTE 1 The reduced loadability (related to the countersunk head dimensions in combination with penetration of the hexalobular socket specified in this document) implies a limitation of ultimate tensile load shown by a specific marking (property class preceded by a zero). The loadability in the head is assumed to be 80 % of that in the thread for all sizes and all property classes; see [Table 3](#).

NOTE 2 Hexalobular socket countersunk head screws (high head), with full loadability are specified in ISO 14582, but these products are not interchangeable, because of different head heights.

NOTE 3 Particular attention is needed to ensure alignment of the countersunk head with the bearing surface of the countersink in the assembly.

2 Normative references

The following documents are referred to in the text in such a way that some or all of their content constitutes requirements of this document. For dated references, only the edition cited applies. For undated references, the latest edition of the referenced document (including any amendments) applies.

ISO 225, *Fasteners — Bolts, screws, studs and nuts — Symbols and descriptions of dimensions*

ISO 888, *Fasteners — Bolts, screws and studs — Nominal lengths and thread lengths*

ISO 898-1, *Mechanical properties of fasteners made of carbon steel and alloy steel — Part 1: Bolts, screws and studs with specified property classes — Coarse thread and fine pitch thread*

ISO 965-1, *ISO general purpose metric screw threads — Tolerances — Part 1: Principles and basic data*

ISO 1891-4, *Fasteners — Vocabulary — Part 4: Control, inspection, delivery, acceptance and quality*

ISO 3269, *Fasteners — Acceptance inspection*

ISO 3506-1, *Fasteners — Mechanical properties of corrosion-resistant stainless steel fasteners — Part 1: Bolts, screws and studs with specified grades and property classes*

ISO 3508, *Thread run-outs for fasteners with thread in accordance with ISO 261 and ISO 262*

ISO 4042, *Fasteners — Electroplated coating systems*

ISO 4753, *Fasteners — Ends of parts with external ISO metric thread*

ISO 4759-1, *Tolerances for fasteners — Part 1: Bolts, screws, studs and nuts — Product grades A, B and C*

ISO 6157-1, *Fasteners — Surface discontinuities — Part 1: Bolts, screws and studs for general requirements*

ISO 7721, *Countersunk head screws — Head configuration and gauging*

ISO 8991, *Designation system for fasteners*

ISO 14581:2022(E)

ISO 8992, *Fasteners — General requirements for bolts, screws, studs and nuts*

ISO 10664, *Hexalobular internal driving feature for bolts and screws*

ISO 10683, *Fasteners — Non-electrolytically applied zinc flake coating systems*

3 Terms and definitions

No terms and definitions are listed in this document.

ISO and IEC maintain terminology databases for use in standardization at the following addresses:

- ISO Online browsing platform: available at <https://www.iso.org/obp>
- IEC Electropedia: available at <https://www.electropedia.org/>

4 Dimensions and gauging of the head

4.1 Dimensions

Dimensions shall be in accordance with [Figures 1](#) to [3](#) and with [Table 1](#).

Symbols and descriptions of dimensions are specified in ISO 225.

iTeh STANDARD PREVIEW
(standards.iteh.ai)

<https://standards.iteh.ai/catalog/standards/sist/d166b5e1-c09c-4bed-9681-e9a10c36ea2f/iso-14581-2022>

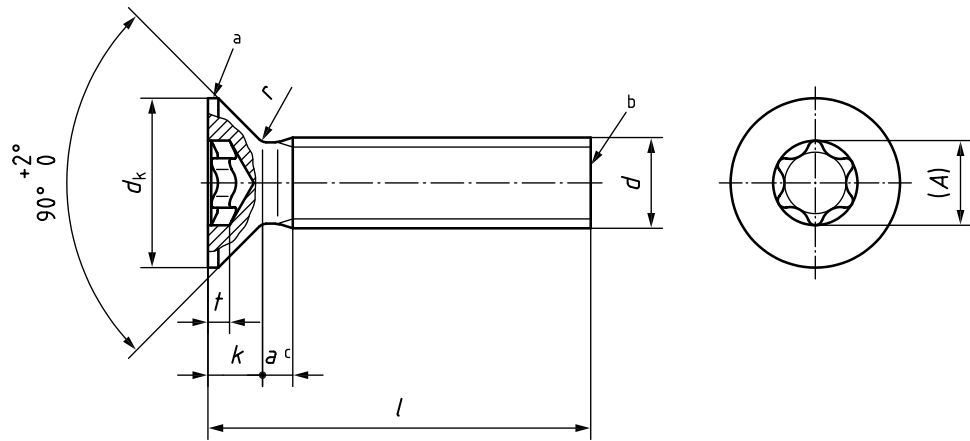

a) Fully threaded screws

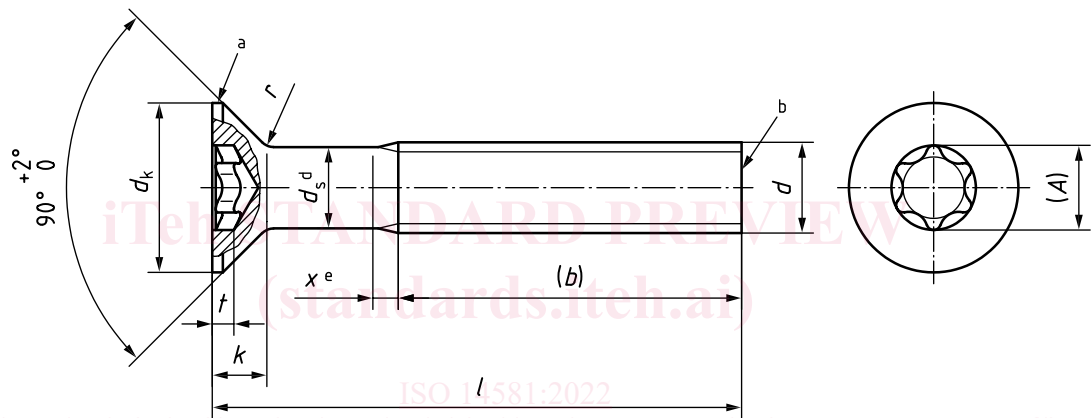

b) Partially threaded screws

- a Contour of the head flat or rounded.
- b As-rolled end (RL) in accordance with ISO 4753.
- c $a_{\max} \leq 2P$ for screws without underhead reinforcement.
- d Shank diameter d_s is approximately equal to the pitch diameter.
- e $x_{\max} \approx 2,5P$, as specified in ISO 3508.

Figure 1 — Screws M2 to M4, without underhead reinforcement

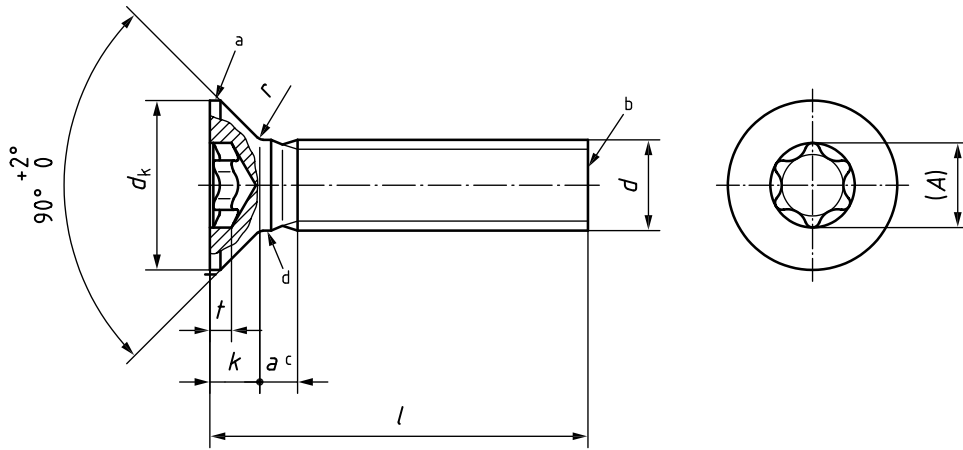

a) Fully threaded screws

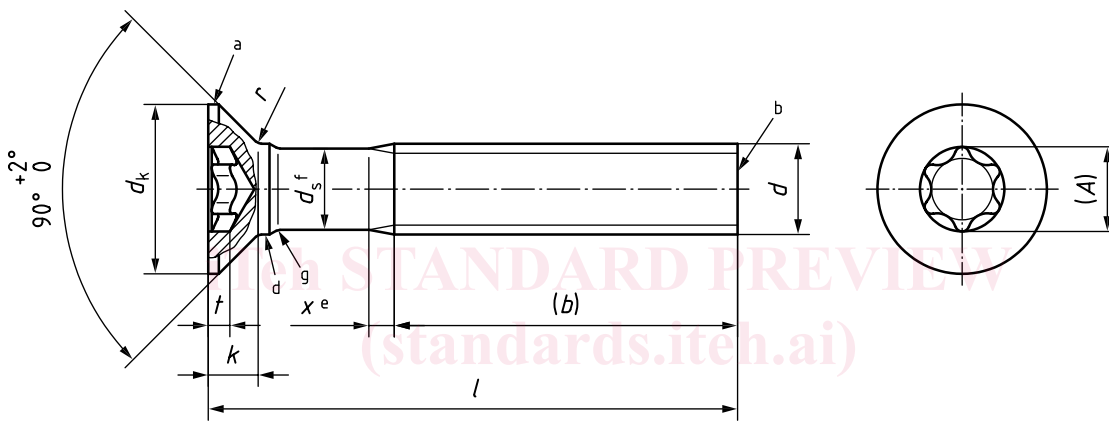

b) Partially threaded screws

- a Contour of the head flat or rounded.
- b As-rolled end (RL) in accordance with ISO 4753.
- c $a_{\max} \leq 2,5P$ for screws with underhead reinforcement.
- d Any shape of the underhead reinforcement is at the discretion of the manufacturer, but it shall not exceed diameter d .
- e $x_{\max} \approx 2,5P$, as specified in ISO 3508.
- f Shank diameter d_s is approximately equal to the pitch diameter.
- g Smooth transition between underhead reinforcement and the shank at the discretion of the manufacturer.

Figure 2 — Screws M5 to M10, with underhead reinforcement