



Designation: ~~D3527-07~~^{ε1} Designation: D3527 - 11

Standard Test Method for Life Performance of Automotive Wheel Bearing Grease¹

This standard is issued under the fixed designation D3527; the number immediately following the designation indicates the year of original adoption or, in the case of revision, the year of last revision. A number in parentheses indicates the year of last reapproval. A superscript epsilon (ϵ) indicates an editorial change since the last revision or reapproval.

~~ε¹Note—Added Note 5 editorially in January 2009.~~

1. Scope*

1.1 This test method covers a laboratory procedure for evaluating the high-temperature life performance of wheel bearing greases when tested under prescribed conditions.

NOTE 1—Changes to this test method in the 1985 revision increased test severity. Results will not be comparable with data from earlier procedures.

1.2 The values stated in SI units are to be regarded as standard. No other units of measurement are included in this standard.

1.2.1 *Exception*—Apparatus dimensions in inches are to be regarded as the standard.

1.3 *This standard does not purport to address all of the safety concerns, if any, associated with its use. It is the responsibility of the user of this standard to establish appropriate safety and health practices and determine the applicability of regulatory limitations prior to use.* For specific warning statements, see 8.1-8.4.

2. Referenced Documents

2.1 *AFBMA Standard:*

AFBMA Standard 19, 1974 (ANSI B. 3.19-1975)²

3. Terminology

3.1 *Definitions:*

3.1.1 *lubricant, n*—any material interposed between two surfaces that reduces the friction or wear between them.

3.1.2 *lubricating grease, n*—a semi-fluid to solid product of a dispersion of a thickener in a liquid lubricant.

3.1.2.1 *Discussion*—The dispersion of the thickener forms a two-phase system and immobilizes the liquid lubricant by surface tension and other physical forces. Other ingredients are commonly included to impart special properties.

3.1.3 *thickener, n*—*in lubricating grease*, a substance composed of finely-divided particles dispersed in a liquid lubricant to form the product's structure.

3.1.3.1 *Discussion*—The solid thickener can be fibers (such as various metallic soaps) or plates or spheres (such as certain non-soap thickeners) which are insoluble or, at the most, only very slightly soluble in the liquid lubricant. The general requirements are that the solid particles be extremely small, uniformly dispersed, and capable of forming a relatively stable, gel-like structure with the liquid lubricant.

3.2 *Definitions of Terms Specific to This Standard:*

3.2.1 *automotive wheel bearing grease, n*—a lubricating grease specifically formulated to lubricate automotive wheel bearings at relatively high grease temperatures and bearing speeds.

3.2.2 *grease life, n*—*of wheel bearing grease*, amount of time operated under prescribed conditions of load, speed, and temperature until preset torque limit is exceeded.

3.2.2.1 *Discussion*—The *off-time*, which is part of the 20 h and 4 h off-cycle, is not recorded and is not included as part of grease life.

4. Summary of Test Method

4.1 The test grease is distributed in the bearings of a modified, automobile front wheel hub-spindle-bearings assembly. While the bearings are thrust-loaded to 111 N, the hub is rotated at 1000 rpm and the spindle temperature maintained at 160°C for 20

¹ This test method is under the jurisdiction of ASTM Committee D02 on Petroleum Products and Lubricants and is the direct responsibility of Subcommittee D02.G0.05 on Functional Tests - Temperature.

Current edition approved July 15, 2007. Published August 2007. Originally approved in 1976. Last previous edition approved in 2002 as D3527-02. DOI: 10.1520/D3527-07E01.

Current edition approved Nov. 1, 2011. Published December 2011. Originally approved in 1976. Last previous edition approved in 2007 as D3527-07 ^{ε1}. DOI: 10.1520/D3527-11.

² Available from American National Standards Institute (ANSI), 25 W. 43rd St., 4th Floor, New York, NY 10036, <http://www.ansi.org>.

*A Summary of Changes section appears at the end of this standard.

h, 4 h off operating cycle. The test is terminated when grease deterioration causes the drive motor torque to exceed a calculated motor cut off value. Grease life is expressed as the accumulated on-cycle hours.

5. Significance and Use

5.1 This test method differentiates among wheel bearing greases having distinctly different high-temperature characteristics. It is not the equivalent of longtime service tests, nor is it intended to distinguish between the products having similar high-temperature performance properties.

5.2 This test method has proven to be helpful in screening greases with respect to life performance for automotive wheel bearing applications.

6. Apparatus

6.1 *Test Assembly* (see Fig. 1 and Fig. 2).

6.1.1 *Custom-made Wheel Hub-Spindle-Bearing Assembly* (Fig. 3).

6.1.2 *Oven*, electrically heated by 4800a 1200 watt heater, thermostatically controlled to maintain spindle temperature at $160 \pm 1.5^\circ\text{C}$.

6.1.3 *Spindle Drive Motor*, 1/4 hp, 120 volts dc with 1725 rpm speed control the hub; motor torque is indicated by a meter equipped with an adjustable, automatic cut-off.

6.1.4 *Fan Drive Motor*, 1/30 hp, 120 v dc, 1550 rpm.

6.2 Motor speed, oven temperature, spindle temperature, time cycles and torque are controlled or monitored, or both, by accessory equipment.

6.3 *Balance* having a minimum capacity of 100 g and minimum sensitivity of 0.1 g.

7. Test Bearings

7.1 Use LM67048-LM67010 and LM11949-LM11910 (AFBMA Standard 19) inboard and outboard bearings,³ respectively.

8. Reagents and Materials

8.1 *n-Heptane*—reagent grade minimum purity (**Warning**—Flammable. Harmful if inhaled.)

8.2 *Isopropyl Alcohol*—reagent grade minimum purity (**Warning**—Flammable.)

8.3 *Penmul L460 (previously called Penetone ECS)*⁴—(**Warning**—Combustible. Vapors can be harmful.)

³The sole source of supply of the test assembly known to the committee at this time is Koehler Instrument Co., Inc., 1595 Sycamore Ave., Bohemia, Long Island, NY 11716. If you are aware of alternative suppliers, please provide this information to ASTM International Headquarters. Your comments will receive careful consideration at a meeting of the responsible technical committee, which you may attend.

³Timken or Bower bearings are suitable.

⁴Timken or Bower bearings are suitable.

⁴The sole source of supply of Penmul L460 (previously called Penetone ECS) known to the committee at this time is Penetone Corp., 74 Hudson Ave., Tenafly, NJ 07670. If you are aware of alternative suppliers, please provide this information to ASTM International Headquarters. Your comments will receive careful consideration at a meeting of the responsible technical committee, which you may attend.

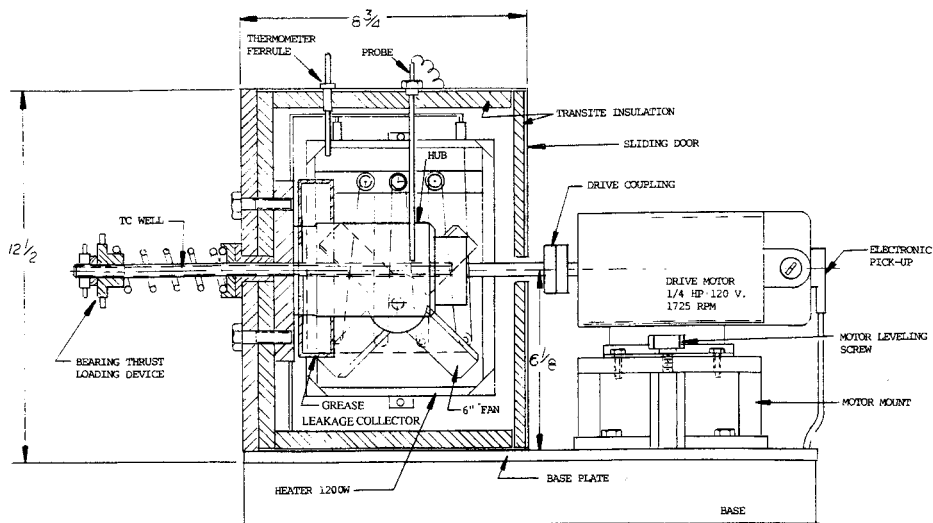

NOTE—Caution should be taken when modifying older units since some may still contain asbestos insulation leading to a possible inhalation hazard.

FIG. 1 Wheel Bearing Lubricant Tester (Elevation View)

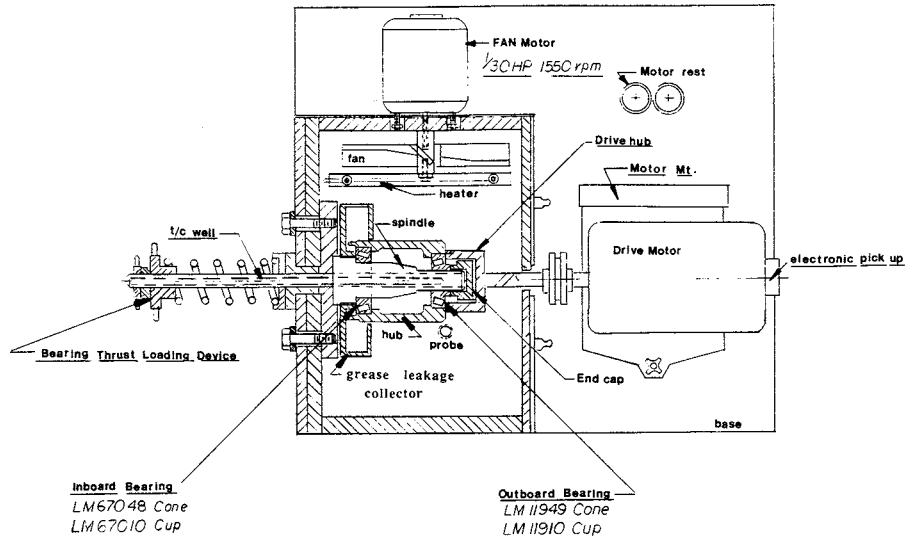

FIG. 2 Wheel Bearing Lubricant Tester (Top View)

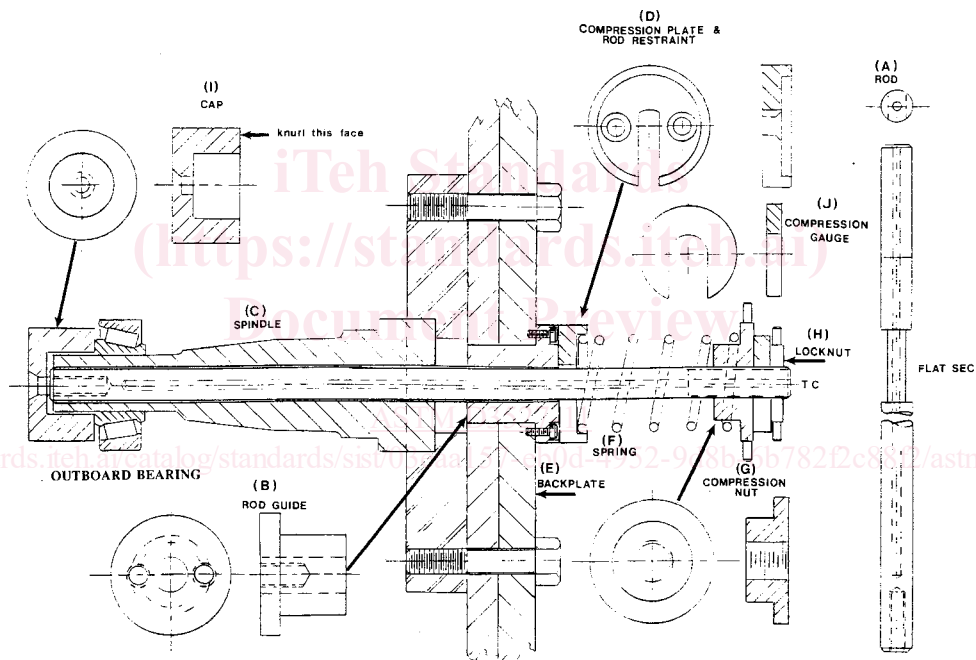

FIG. 3 Spindle and Thrust Rod Components

8.4 Mineral Spirits, Reagent Grade—(Warning—Combustible. Vapors may be harmful.)

8.5 SAE 10W Engine Oil.

8.6 00 Grade Steel Wool.

9. Preparation of Bearings

9.1 Carefully remove new bearings (cups and cones) from their packages and place in a suitable clean container. Wash with *n*-Heptane to remove all rust preventative.

9.2 Repeat washing with *n*-Heptane two additional times to be certain all rust preventative has been removed. Use a clean beaker each time.

9.3 Drain *n*-Heptane from the bearings and set them on a clean, lint-free cloth or towel to air dry.

NOTE 2—Cleaning may be facilitated by the use of a sonic cleaner.

10. Procedure

10.1 Prior to each test, check the freedom of movement of the thrust loading shaft (Fig. 3) in the spindle. If binding is noted, remove and clean both shaft and spindle bore.

10.2 Install the new cups in the cleaned hub in the location shown in Figs. 1 and 2.

10.3 Weigh an inboard and outboard bearing cone to the nearest 0.1 g. Fill the cones with test grease using an extra set of cups and the grease packer shown in Figs. 4 and 5. Use care to avoid moving the rollers or bearing components while removing the cones from the cups and in all subsequent wiping and handling steps. Strike off excess grease flush with the front face of the cone (near small end of rollers) using a small spatula. Wipe all grease from cone bore, cone back face, exterior cage surfaces, and exposed roller surfaces with a clean, lint-free cloth or towel and reweigh. Adjust the grease weight in the inboard cone to 3.0 ± 0.1 g and in the outboard cone to 2.0 ± 0.1 g by wiping or adding grease to the groove between the cage and the cone back face. Apply a thin film of grease on the cups.

10.4 Install the leakage collector, inboard cone, hub, and outboard cone on the spindle (Fig. 2). Lock the components in place with the end cap and screw. Install the spindle connector.

10.5 Referring to Fig. 3, adjust the thrust load as follows: tighten the compression nut *G* until the spring *F* is seated against the back plate *E*, but not compressed. Bring the lock nut *H* up to the compression nut *G*. Without moving *H*, compress *F* by tightening *G* until the compression gage *J* will fit between *H* and *G*. Hold *J* in position and back off *G* until *J* is held firmly between *H* and *G*.

NOTE 3—Compression gage *J* has been machined such that insertion and adjustment of *G* causes spring *F* to compress and apply a 111-N (25-lbf) axial load on the wheel bearings.

10.6 Insert the thermocouple in the spindle thrust rod and position the junction at the center of the outboard bearing position. Close the cabinet and position the motor to operating location. (**Warning**—Do not engage the drive at this point. Start the motor and adjust the speed to 1000 ± 50 rpm. At this point observe and record the unloaded motor current *N*.)

10.7 Turn off the motor, engage the drive coupling and lock in position. Set the timer to begin a 20-h cycle. Restart the motor and again adjust the speed to 1000 ± 50 rpm. Turn on the heaters and adjust the oven temperature to maintain the spindle temperature at $160 \pm 1.5^\circ\text{C}$ ($320 \pm 2.7^\circ\text{F}$). When the spindle temperature has stabilized at the test temperature, make no further adjustment of the oven temperature for the duration of the test.

10.8 A steady-state running torque will develop in the first 2 h of operation as indicated by a stabilized value on the meter. Record this value as steady-state current *T*. Determine the motor cutoff value as follows:

$$C = 8(T - N) + N \tag{1}$$

Document Preview
<https://standards.iteh.ai>
 (https://standards.iteh.ai)

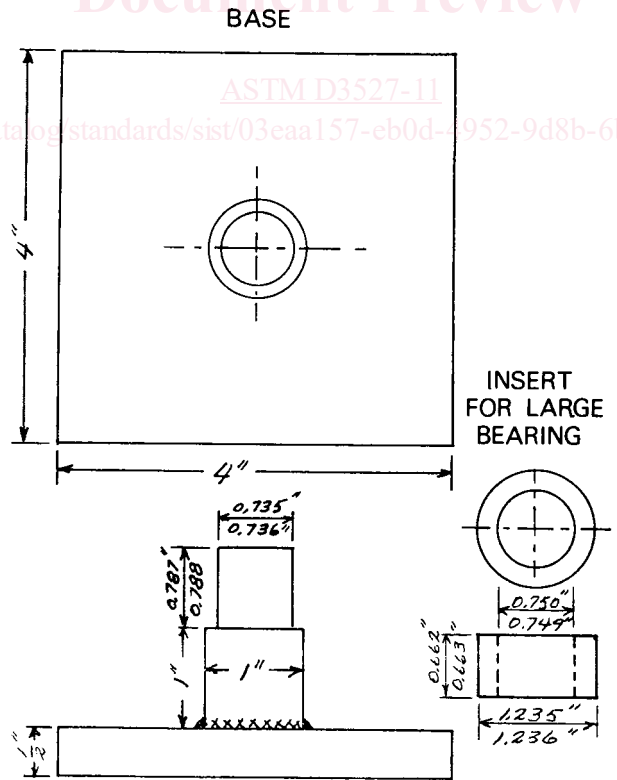

MATL: STAINLESS STEEL
 FIG. 4 Bearing Packer