

---

---

**ISO metric trapezoidal screw  
threads — Basic dimensions**

*Filetages métriques trapézoïdaux ISO — Dimensions de base*

**iTeh STANDARD PREVIEW**  
**(standards.iteh.ai)**

[ISO 2904:2020](https://standards.iteh.ai/catalog/standards/sist/edff30b0-dff9-4765-86be-377641e97636/iso-2904-2020)

<https://standards.iteh.ai/catalog/standards/sist/edff30b0-dff9-4765-86be-377641e97636/iso-2904-2020>



**iTeh STANDARD PREVIEW**  
**(standards.iteh.ai)**

ISO 2904:2020

<https://standards.iteh.ai/catalog/standards/sist/edff30b0-dff9-4765-86be-377641e97636/iso-2904-2020>



**COPYRIGHT PROTECTED DOCUMENT**

© ISO 2020

All rights reserved. Unless otherwise specified, or required in the context of its implementation, no part of this publication may be reproduced or utilized otherwise in any form or by any means, electronic or mechanical, including photocopying, or posting on the internet or an intranet, without prior written permission. Permission can be requested from either ISO at the address below or ISO's member body in the country of the requester.

ISO copyright office  
CP 401 • Ch. de Blandonnet 8  
CH-1214 Vernier, Geneva  
Phone: +41 22 749 01 11  
Fax: +41 22 749 09 47  
Email: [copyright@iso.org](mailto:copyright@iso.org)  
Website: [www.iso.org](http://www.iso.org)

Published in Switzerland

# Contents

	Page
Foreword .....	iv
<b>1 Scope .....</b>	<b>1</b>
<b>2 Normative references .....</b>	<b>1</b>
<b>3 Terms and definitions .....</b>	<b>1</b>
<b>4 Symbols .....</b>	<b>1</b>
<b>5 Basic dimensions .....</b>	<b>2</b>
<b>Bibliography .....</b>	<b>8</b>

## iTeh STANDARD PREVIEW (standards.iteh.ai)

[ISO 2904:2020](https://standards.iteh.ai/catalog/standards/sist/edff30b0-dff9-4765-86be-377641e97636/iso-2904-2020)

<https://standards.iteh.ai/catalog/standards/sist/edff30b0-dff9-4765-86be-377641e97636/iso-2904-2020>

## Foreword

ISO (the International Organization for Standardization) is a worldwide federation of national standards bodies (ISO member bodies). The work of preparing International Standards is normally carried out through ISO technical committees. Each member body interested in a subject for which a technical committee has been established has the right to be represented on that committee. International organizations, governmental and non-governmental, in liaison with ISO, also take part in the work. ISO collaborates closely with the International Electrotechnical Commission (IEC) on all matters of electrotechnical standardization.

The procedures used to develop this document and those intended for its further maintenance are described in the ISO/IEC Directives, Part 1. In particular, the different approval criteria needed for the different types of ISO documents should be noted. This document was drafted in accordance with the editorial rules of the ISO/IEC Directives, Part 2 (see [www.iso.org/directives](http://www.iso.org/directives)).

Attention is drawn to the possibility that some of the elements of this document may be the subject of patent rights. ISO shall not be held responsible for identifying any or all such patent rights. Details of any patent rights identified during the development of the document will be in the Introduction and/or on the ISO list of patent declarations received (see [www.iso.org/patents](http://www.iso.org/patents)).

Any trade name used in this document is information given for the convenience of users and does not constitute an endorsement.

For an explanation of the voluntary nature of standards, the meaning of ISO specific terms and expressions related to conformity assessment, as well as information about ISO's adherence to the World Trade Organization (WTO) principles in the Technical Barriers to Trade (TBT), see [www.iso.org/iso/foreword.html](http://www.iso.org/iso/foreword.html).

This document was prepared by Technical Committee ISO/TC 1, *Screw threads*.

This second edition cancels and replaces the first edition (ISO 2904:1977), which has been technically revised.

The main changes compared to the previous edition are as follows:

- In [Clause 1](#) (Scope) the phrase “basic profiles” has been replaced by “design profiles”.
- In [Clause 1](#) (Scope) the second paragraph has been added.
- [Clause 3](#) (Terms and definitions) has been added.
- “BASIC PROFILES (modified)”, the title of ISO 2904:1977, Clause 4, has been replaced by “Basic dimensions”, the title of ISO 2904:2019, Clause 5.
- Table 1 has been deleted.

Any feedback or questions on this document should be directed to the user's national standards body. A complete listing of these bodies can be found at [www.iso.org/members.html](http://www.iso.org/members.html).

# ISO metric trapezoidal screw threads — Basic dimensions

## 1 Scope

This document specifies the basic dimensions of ISO metric trapezoidal screw threads in accordance with ISO 2902. The values refer to the design profiles in accordance with ISO 2901.

This document is chiefly applicable to traversing threads for traversing motion on machines, tools, etc. It can also be used for fastening threads.

## 2 Normative references

The following documents are referred to in the text in such a way that some or all of their content constitutes requirements of this document. For dated references, only the edition cited applies. For undated references, the latest edition of the referenced document (including any amendments) applies.

ISO 5408, *Screw threads — Vocabulary*

## 3 Terms and definitions

For the purposes of this document, the terms and definitions given in ISO 5408 apply.

ISO and IEC maintain terminological databases for use in standardization at the following addresses:

- ISO Online browsing platform: available at <https://www.iso.org/obp>
- IEC Electropedia: available at <http://www.electropedia.org/>

## 4 Symbols

For the purposes of this document, the following symbols apply.

- $D_1$  basic minor diameter of internal thread
- $D_2$  basic pitch diameter of internal thread
- $D_4$  basic major diameter of internal thread
- $d$  basic major diameter of external thread (nominal diameter)
- $d_2$  basic pitch diameter of external thread
- $d_3$  basic minor diameter of external thread
- $P$  pitch
- $a_c$  clearance at major and minor diameters
- $R_1$  radius on crest corners of external thread on design profile
- $R_2$  radius on root corners of internal and external threads on design profile

### 5 Basic dimensions

Basic dimensions shown in [Figure 1](#) are given in [Table 1](#).

The values of  $D_1$ ,  $D_2$ ,  $D_4$ ,  $d_2$  and  $d_3$ , in [Table 1](#), have been calculated from the following formulae and rounded to the third decimal place.

$$D_1 = d - P$$

$$D_2 = d_2 = d - 0,5 P$$

$$D_4 = d + 2 a_c$$

$$d_3 = d - P - 2 a_c$$

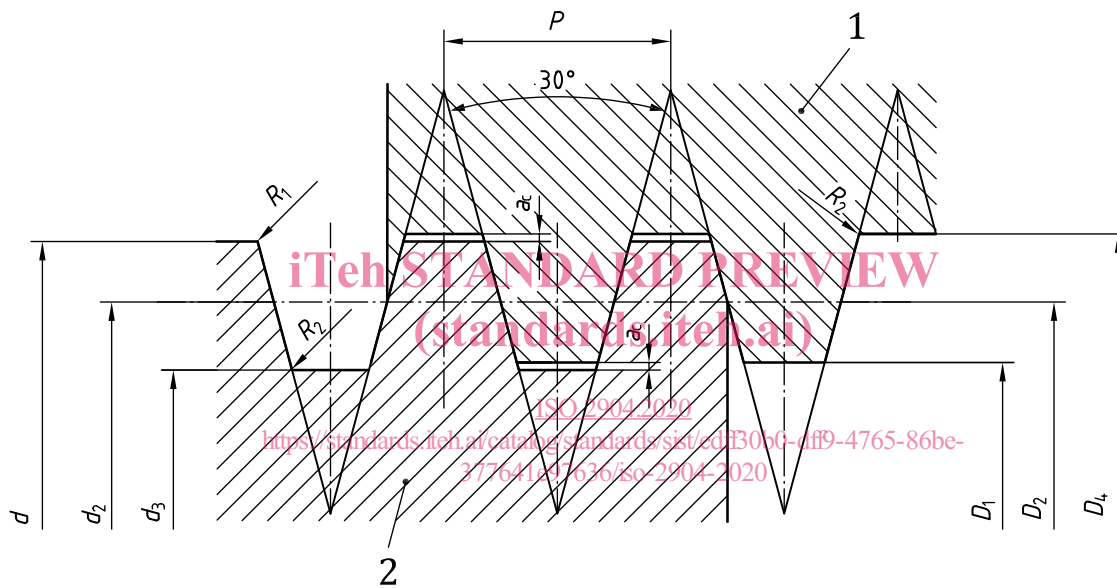

**Key**

- 1 internal thread
- 2 external thread

**Figure 1 — Basic dimensions**

**Table 1 — Basic dimensions**

Dimensions in millimetres

Nominal diameters			Pitch $P$	Pitch diameter $d_2 = D_2$	Major diameter $D_4$	Minor diameter	
column 1	column 2	column 3				$d_3$	$D_1$
8			1,5	7,250	8,300	6,200	6,500
	9		1,5 2	8,250 8,000	9,300 9,500	7,200 6,500	7,500 7,000
10			1,5 2	9,250 9,000	10,300 10,500	8,200 7,500	8,500 8,000
	11		2 3	10,000 9,500	11,500 11,500	8,500 7,500	9,000 8,000

Table 1 (continued)

Nominal diameters			Pitch	Pitch diameter	Major diameter	Minor diameter	
$d$			$P$	$d_2 = D_2$	$D_4$	$d_3$	$D_1$
column 1	column 2	column 3					
12			2	11,000	12,500	9,500	10,000
			3	10,500	12,500	8,500	9,000
	14		2	13,000	14,500	11,500	12,000
			3	12,500	14,500	10,500	11,000
16			2	15,000	16,500	13,500	14,000
			4	14,000	16,500	11,500	12,000
	18		2	17,000	18,500	15,500	16,000
			4	16,000	18,500	13,500	14,000
20			2	19,000	20,500	17,500	18,000
			4	18,000	20,500	15,500	16,000
	22		3	20,500	22,500	18,500	19,000
			5	19,500	22,500	16,500	17,000
			8	18,000	23,000	13,000	14,000
24			3	22,500	24,500	20,500	21,000
			5	21,500	24,500	18,500	19,000
			8	20,000	25,000	15,000	16,000
	26		3	24,500	26,500	22,500	23,000
			5	23,500	26,500	20,500	21,000
			8	22,000	27,000	17,000	18,000
28			3	26,500	28,500	24,500	25,000
			5	25,500	28,500	22,500	23,000
			8	24,000	29,000	19,000	20,000
	30		3	28,500	30,500	26,500	27,000
			6	27,000	31,000	23,000	24,000
			10	25,000	31,000	19,000	20,000
32			3	30,500	32,500	28,500	29,000
			6	29,000	33,000	25,000	26,000
			10	27,000	33,000	21,000	22,000
	34		3	32,500	34,500	30,500	31,000
			6	31,000	35,000	27,000	28,000
			10	29,000	35,000	23,000	24,000
36			3	34,500	36,500	32,500	33,000
			6	33,000	37,000	29,000	30,000
			10	31,000	37,000	25,000	26,000
	38		3	36,500	38,500	34,500	35,000
			7	34,500	39,000	30,000	31,000
			10	33,000	39,000	27,000	28,000
40			3	38,500	40,500	36,500	37,000
			7	36,500	41,000	32,000	33,000
			10	35,000	41,000	29,000	30,000

Table 1 (continued)

Nominal diameters			Pitch <i>P</i>	Pitch diameter $d_2 = D_2$	Major diameter $D_4$	Minor diameter	
<i>d</i> column 1	column 2	column 3				$d_3$	$D_1$
42			3	40,500	42,500	38,500	39,000
			7	38,500	43,000	34,000	35,000
			10	37,000	43,000	31,000	32,000
44			3	42,500	44,500	40,500	41,000
			7	40,500	45,000	36,000	37,000
			12	38,000	45,000	31,000	32,000
46			3	44,500	46,500	42,500	43,000
			8	42,000	47,000	37,000	38,000
			12	40,000	47,000	33,000	34,000
48			3	46,500	48,500	44,500	45,000
			8	44,000	49,000	39,000	40,000
			12	42,000	49,000	35,000	36,000
50			3	48,500	50,500	46,500	47,000
			8	46,000	51,000	41,000	42,000
			12	44,000	51,000	37,000	38,000
52			3	50,500	52,500	48,500	49,000
			8	48,000	53,000	43,000	44,000
			12	46,000	53,000	39,000	40,000
55			3	53,500	55,500	51,500	52,000
			9	50,500	56,000	45,000	46,000
			14	48,000	57,000	39,000	41,000
60			3	58,500	60,500	56,500	57,000
			9	55,500	61,000	50,000	51,000
			14	53,000	62,000	44,000	46,000
65			4	63,000	65,500	60,500	61,000
			10	60,000	66,000	54,000	55,000
			16	57,000	67,000	47,000	49,000
70			4	68,000	70,500	65,500	66,000
			10	65,000	71,000	59,000	60,000
			16	62,000	72,000	52,000	54,000
75			4	73,000	75,500	70,500	71,000
			10	70,000	76,000	64,000	65,000
			16	67,000	77,000	57,000	59,000
80			4	78,000	80,500	75,500	76,000
			10	75,000	81,000	69,000	70,000
			16	72,000	82,000	62,000	64,000
85			4	83,000	85,500	80,500	81,000
			12	79,000	86,000	72,000	73,000
			18	76,000	87,000	65,000	67,000
90			4	88,000	90,500	85,500	86,000
			12	84,000	91,000	77,000	78,000
			18	81,000	92,000	70,000	72,000



Table 1 (continued)

Nominal diameters			Pitch	Pitch diameter	Major diameter	Minor diameter	
$d$			$P$	$d_2 = D_2$	$D_4$	$d_3$	$D_1$
column 1	column 2	column 3					
	95		4	93,000	95,500	90,500	91,000
			12	89,000	96,000	82,000	83,000
			18	86,000	97,000	75,000	77,000
100			4	98,000	100,500	95,500	96,000
			12	94,000	101,000	87,000	88,000
			20	90,000	102,000	78,000	80,000
		105	4	103,000	105,500	100,500	101,000
			12	99,000	106,000	92,000	93,000
			20	95,000	107,000	83,000	85,000
	110		4	108,000	110,500	105,500	106,000
			12	104,000	111,000	97,000	98,000
			20	100,000	112,000	88,000	90,000
		115	6	112,000	116,000	108,000	109,000
			14	108,000	117,000	99,000	101,000
			22	104,000	117,000	91,000	93,000
120			6	117,000	121,000	113,000	114,000
			14	113,000	122,000	104,000	106,000
			22	109,000	122,000	96,000	98,000
		125	6	122,000	126,000	118,000	119,000
			14	118,000	127,000	109,000	111,000
			22	114,000	127,000	101,000	103,000
	130		6	127,000	131,000	123,000	124,000
			14	123,000	132,000	114,000	116,000
			22	119,000	132,000	106,000	108,000
		135	6	132,000	136,000	128,000	129,000
			14	128,000	137,000	119,000	121,000
			24	123,000	137,000	109,000	111,000
140			6	137,000	141,000	133,000	134,000
			14	133,000	142,000	124,000	126,000
			24	128,000	142,000	114,000	116,000
		145	6	142,000	146,000	138,000	139,000
			14	138,000	147,000	129,000	131,000
			24	133,000	147,000	119,000	121,000
	150		6	147,000	151,000	143,000	144,000
			16	142,000	152,000	132,000	134,000
			24	138,000	152,000	124,000	126,000
		155	6	152,000	156,000	148,000	149,000
			16	147,000	157,000	137,000	139,000
			24	143,000	157,000	129,000	131,000
160			6	157,000	161,000	153,000	154,000
			16	152,000	162,000	142,000	144,000
			28	146,000	162,000	130,000	132,000