



Designation: C273/C273M – 11

Standard Test Method for Shear Properties of Sandwich Core Materials¹

This standard is issued under the fixed designation C273/C273M; the number immediately following the designation indicates the year of original adoption or, in the case of revision, the year of last revision. A number in parentheses indicates the year of last reapproval. A superscript epsilon (ϵ) indicates an editorial change since the last revision or reapproval.

This standard has been approved for use by agencies of the U.S. Department of Defense.

1. Scope

1.1 This test method covers the determination of shear properties of sandwich construction core materials associated with shear distortion of planes parallel to the facings. It covers the determination of shear strength parallel to the plane of the sandwich, and the shear modulus associated with strains in a plane normal to the facings. The test may be conducted on core materials bonded directly to the loading plates or the sandwich facings bonded to the plates. Permissible core material forms include those with continuous bonding surfaces (such as balsa wood and foams) as well as those with discontinuous bonding surfaces (such as honeycomb).

1.2 The values stated in either SI units or inch-pound units are to be regarded separately as standard. The values stated in each system may not be exact equivalents; therefore, each system shall be used independently of the other. Combining values from the two systems may result in non-conformance with the standard.

1.2.1 Within the text the inch-pound units are shown in brackets.

1.3 *This standard does not purport to address all of the safety concerns, if any, associated with its use. It is the responsibility of the user of this standard to establish appropriate safety and health practices and determine the applicability of regulatory limitations prior to use.*

2. Referenced Documents

2.1 *ASTM Standards:*²

- [C271/C271M Test Method for Density of Sandwich Core Materials](#)
- [C274 Terminology of Structural Sandwich Constructions](#)
- [C393 Test Method for Flexural Properties of Sandwich Constructions](#)

¹ This test method is under the jurisdiction of ASTM Committee D30 on Composite Materials and is the direct responsibility of Subcommittee D30.09 on Sandwich Construction.

Current edition approved Nov. 15, 2011. Published December 2011. Originally approved in 1951. Last previous edition approved in 2007 as C273 – 07a. DOI: 10.1520/C0273_C0273M-11.

² For referenced ASTM standards, visit the ASTM website, www.astm.org, or contact ASTM Customer Service at service@astm.org. For *Annual Book of ASTM Standards* volume information, refer to the standard's Document Summary page on the ASTM website.

- [D792 Test Methods for Density and Specific Gravity \(Relative Density\) of Plastics by Displacement](#)
- [D883 Terminology Relating to Plastics](#)
- [D2584 Test Method for Ignition Loss of Cured Reinforced Resins](#)
- [D2734 Test Methods for Void Content of Reinforced Plastics](#)
- [D3171 Test Methods for Constituent Content of Composite Materials](#)
- [D3878 Terminology for Composite Materials](#)
- [D5229/D5229M Test Method for Moisture Absorption Properties and Equilibrium Conditioning of Polymer Matrix Composite Materials](#)
- [D5687/D5687M Guide for Preparation of Flat Composite Panels with Processing Guidelines for Specimen Preparation](#)
- [D5961/D5961M Test Method for Bearing Response of Polymer Matrix Composite Laminates](#)
- [E4 Practices for Force Verification of Testing Machines](#)
- [E6 Terminology Relating to Methods of Mechanical Testing](#)
- [E122 Practice for Calculating Sample Size to Estimate, With Specified Precision, the Average for a Characteristic of a Lot or Process](#)
- [E177 Practice for Use of the Terms Precision and Bias in ASTM Test Methods](#)
- [E456 Terminology Relating to Quality and Statistics](#)
- [E1309 Guide for Identification of Fiber-Reinforced Polymer-Matrix Composite Materials in Databases](#)
- [E1434 Guide for Recording Mechanical Test Data of Fiber-Reinforced Composite Materials in Databases](#)
- [E1471 Guide for Identification of Fibers, Fillers, and Core Materials in Computerized Material Property Databases](#)

3. Terminology

3.1 *Definitions*—Terminology [D3878](#) defines terms relating to high-modulus fibers and their composites. Terminology [C274](#) defines terms relating to structural sandwich constructions. Terminology [D883](#) defines terms relating to plastics. Terminology [E6](#) defines terms relating to mechanical testing. Terminology [E456](#) and Practice [E177](#) define terms relating to statistics. In the event of a conflict between terms, Terminology [D3878](#) shall have precedence over the other terminologies.

3.2 Symbols:

b = width of specimen

CV = coefficient of variation statistic of a sample population for a given property (in percent)

G = core shear modulus

L = length of specimen

P = force on specimen

$S = \Delta P / \Delta u$, slope of initial portion of force-deflection curve

S_{n-1} = standard deviation statistic of a sample population for a given property

t = thickness of core

u = displacement of loading plates

x_1 = test result for an individual specimen from the sample population for a given property

\bar{x} = mean or average (estimate of mean) of a sample population for a given property

γ = core engineering shear strain

τ = core shear stress

4. Summary of Test Method

4.1 This test method consists of subjecting a sandwich core or sandwich panel to monotonically increasing shear force parallel to the plane of its faces. The force is transmitted to the specimen through bonded loading plates that are subjected to opposing tensile or compressive displacements that result in a shear force on the sandwich core. Core shear modulus, stress, and strength are reported in terms of the nominal shear area of the core.

4.2 The only acceptable failure mode is shear failure of the core material. Adhesive or cohesive failures, or both, at the core-to-facesheet, facesheet-to-load-plate, or (if no facesheets are used) core-to-load-plate interface are not acceptable failure modes.

5. Significance and Use

5.1 The core shear properties are fundamental properties that are used in the design of sandwich panels. This test method provides information on the force-deflection behavior of sandwich constructions or cores when loaded in shear parallel to the plane of the facings. From a complete force-deflection curve, it is possible to compute core shear stress at any force (such as the shear stress at proportional limit, at yield, or at maximum force) and to compute an effective core shear modulus.

5.2 The test does not produce pure shear, but the specimen length is prescribed so that secondary stresses have a minimum effect. Approximate shear properties can also be obtained from a sandwich flexure test (see Test Method C393).

5.3 This test method provides a standard method of obtaining sandwich core shear data for material specifications, sandwich panel design, research and development applications, and quality assurance.

5.4 Factors that influence core shear strength and shall therefore be reported include the following: facing material, core material, adhesive material, methods of material fabrication, core geometry (density, cell size, orientation, etc.), adhesive thickness, specimen geometry and associated measurement accuracy, specimen preparation, specimen

conditioning, environment of testing, specimen alignment, loading procedure, speed of testing, and adhesive void content. Further, core-to-facing strength may be different between precured/bonded and co-cured facings in sandwich panels with the same core and facing material.

6. Interferences

6.1 *Material and Specimen Preparation*—Poor material fabrication practices, lack of control of fiber alignment, and damage induced by improper specimen machining are known causes of high data scatter in composites in general. Specific material factors that affect sandwich composites include variability in core density and degree of cure of resin in both facing matrix material and core bonding adhesive. Important aspects of sandwich panel specimen preparation that contribute to data scatter are incomplete or nonuniform core bonding to facings, misalignment of core and facing elements, the existence of joints, voids or other core and facing discontinuities, out-of-plane curvature, facing thickness variation, and surface roughness. For this particular core shear test, thickness of the adhesive bond to honeycomb core (adhesive-filled depth into the honeycomb core cells) may affect the core shear strength and modulus values depending on the core thickness.

6.2 *System Alignment*—Unintended loading eccentricities will cause premature failure. Every effort should be made to eliminate undesirable eccentricities from the test system. Such eccentricities may occur as a result of misaligned grips, poor specimen preparation, or poor alignment of the bonded loading plates.

6.3 *Geometry*—Specific geometric factors that affect core shear behavior of sandwich panels includes core cell geometry (shape, density, orientation), core thickness, and adhesive thickness.

6.4 *Environment*—Results are affected by the environmental conditions under which the tests are conducted. Specimens tested in various environments can exhibit significant differences in both static strength and failure mode. Critical environments must be assessed independently for each sandwich construction tested.

7. Apparatus

7.1 *Micrometers*—The micrometer(s) shall use a 4 to 6-mm [0.16 to 0.25-in.] nominal diameter ball-interface on irregular surfaces such as the bag-side of a facing laminate, and a flat anvil interface on core material alone, machined edges, or very smooth-tooled surfaces. The accuracy of the instrument(s) shall be suitable for reading to within 1 % of the sample length, width and thickness. For typical specimen geometries, an instrument with an accuracy of $\pm 25 \mu\text{m}$ [± 0.001 in.] is desirable for thickness, length and width measurement.

7.2 *Test Fixtures*—Either a tensile or compressive loading mode may be used. In either case, the test specimen shall be rigidly supported by means of steel plates bonded to the facings (see Note 1) as shown in Fig. 1. The thickness of the plates may be varied in accordance with the strength of the sandwich (see Note 2), but the plate length shall be such that the line of action of the direct tensile or compressive force shall pass through the

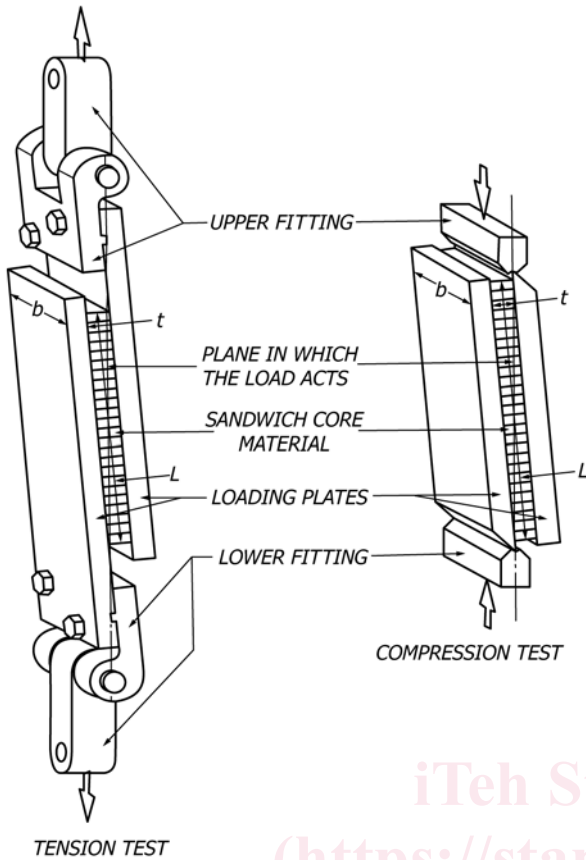

FIG. 1 Plate Shear Specimens, Force Line of Action

diagonally opposite corners of the sandwich as shown in Fig. 1. A correct line of load action may also be obtained by modifying the core length to thickness ratio provided the specimen dimensional requirements noted in 8.2 are fulfilled.

NOTE 1—To ensure a core shear failure on some honeycomb cores, two plies of adhesive must be used to bond the honeycomb to the steel plates. This provides deeper adhesive fillets on the honeycomb cell walls.

NOTE 2—It has been found that loading plates having a bending stiffness per unit width, $D = EI / b$, not less than 2.67 MN · mm²/mm width per millimeter of core thickness (600 000 lb-in.²/in. per inch of core thickness) have performed satisfactorily.

7.2.1 *Tension Loading*—Either pinned or bolted load plate-universal-joint test fixtures, as shown in Fig. 2, may be used. The overall load-train shall be of the suspended, self-aligning type.

7.2.2 *Compression Loading*—Load plates shall taper to a knife-edge and fit into V-notch loading blocks, as shown in Fig. 3. V-notch loading blocks shall be rigidly attached to the test machine and aligned flat and parallel to within ±0.02 mm [±0.001 in.].

7.3 *Testing Machine*—The testing machine shall be in accordance with Practices E4 and shall satisfy the following requirements:

7.3.1 *Testing Machine Configuration*—The testing machine shall have both an essentially stationary head and a movable head.

7.3.2 *Drive Mechanism*—The testing machine drive mechanism shall be capable of imparting to the movable head a

controlled velocity with respect to the stationary head. The velocity of the movable head shall be capable of being regulated in accordance with 11.6.

7.3.3 *Force Indicator*—The testing machine force-sensing device shall be capable of indicating the total force being carried by the test specimen. This device shall be essentially free from inertia lag at the specified rate of testing and shall indicate the force with an accuracy over the force range(s) of interest of within ±1 % of the indicated value.

7.3.4 *Deflectometer, Compressometer, or Extensometer*—The deflection measurement device shall be capable of measuring the displacement with a precision of at least ±1 %.

7.4 *Conditioning Chamber*—When conditioning materials at non-laboratory environments, a temperature/vapor-level controlled environmental conditioning chamber is required that shall be capable of maintaining the required temperature to within ±3°C [±5°F] and the required relative humidity level to within ±3 %. Chamber conditions shall be monitored either on an automated continuous basis or on a manual basis at regular intervals.

7.5 *Environmental Test Chamber*—An environmental test chamber is required for test environments other than ambient testing laboratory conditions. This chamber shall be capable of maintaining the entire test specimen at the required test environment during the mechanical test.

8. Sampling and Test Specimens

8.1 *Sampling*—Test at least five specimens per test condition unless valid results can be gained through the use of fewer specimens, as in the case of a designed experiment. For statistically significant data, consult the procedures outlined in Practice E122. Report the method of sampling.

8.2 *Geometry*—The test specimens shall have a thickness equal to the thickness of the sandwich, a width not less than 50 mm [2.0 in.], and a length not less than twelve times the thickness.

8.3 *Specimen Preparation and Machining*—Guide D5687/D5687M provides recommended specimen preparation practices and should be followed where practical.

8.4 *Labeling*—Label the test specimens so that they will be distinct from each other and traceable back to the panel of origin, and will neither influence the test nor be affected by it.

9. Calibration

9.1 The accuracy of all measuring equipment shall have certified calibrations that are current at the time of use of the equipment.

10. Conditioning

10.1 The recommended pre-test specimen condition is effective moisture equilibrium at a specific relative humidity as established by Test Method D5229/D5229M; however, if the test requester does not explicitly specify a pre-test conditioning environment, conditioning is not required and the test specimens may be tested as prepared.

NOTE 3—The term *moisture*, as used in Test Method D5229/D5229M, includes not only the vapor of a liquid and its condensate, but the liquid