

~~ISO/DIS PRF 23316--5:2022(E)~~

~~ISO-/TC-23/SC-19/AVC-9~~

~~Secretariat:-DIN~~

~~Date: 2022-11-17/2023-08-04~~

**Tractors and machinery for agriculture and forestry — Electrical
~~High Power Interface~~high-power interface 700 V DC / 480 V AC —**

**Part 5:
DC operation mode**

ITeH STANDARD PREVIEW
(standards.iteh.ai)

<https://standards.iteh.ai/catalog/standards/sist/4ce0b81d-36b-4750-9c06-1e8d8c/iso-23316-5>

FDIS stage

~~Edited DIS -
MUST BE USED
FOR FINAL
DRAFT~~

~~Company Use~~

ISO/DISPRF 23316-5:20222023(E)

© ISO 20222023

All rights reserved. Unless otherwise specified, or required in the context of its implementation, no part of this publication may be reproduced or utilized otherwise in any form or by any means, electronic or mechanical, including photocopying, or posting on the internet or an intranet, without prior written permission. Permission can be requested from either ISO at the address below or ISO's member body in the country of the requester.

ISO Copyright Office copyright office
CP 401 • Ch. de Blandonnet 8
CH-1214 Vernier, Geneva
Phone: + 41 22 749 01 11

Email: copyright@iso.org
E-mail: copyright@iso.org
Website: www.iso.org

Published in Switzerland.

iTeh STANDARD PREVIEW (standards.iteh.ai)

ISO 23316-5

<https://standards.iteh.ai/catalog/standards/sist/4ce0b81d-506b-4750-9c06-9265983d0d8c/iso-23316-5>

~~Edited DIS -
MUST BE USED
FOR FINAL
DRAFT~~

Company Use

ii

© ISO 2022 - All rights reserved

ii

© ISO 2023 - All rights reserved

Contents

Foreword vi

Introduction..... vii

1 Scope 1

2 Normative references 1

3 Terms, definitions and symbols 2

3.1 Terms and definitions..... 2

3.2 Symbols..... 2

4 System overview 3

4.1 General..... 3

4.2 Operation with single CS..... 5

4.3 Operation with MCS 5

5 DC specification..... 11

5.1 Voltage form and quality..... 11

5.1.1 System voltage: values and ranges..... 11

5.1.2 Voltage ripple 11

5.1.3 Continuous DC current..... 11

5.1.4 Peak current..... 11

5.1.5 Current specific communication parameters..... 12

5.1.6 Voltage dips and recovery time..... 12

5.1.7 Overvoltage protection..... 12

5.1.8 Overcurrent protection..... 13

5.1.9 System inductance 15

5.1.10 DC link capacitance..... 15

5.1.11 Y-capacitors, parasitic capacitances 16

5.1.12 DC Link pre-charging 16

5.2 DC link discharging procedure..... 19

5.2.1 General..... 19

5.2.2 Connection of MCS..... 19

5.3 Compatibility criteria for PS, HPI and load 19

5.3.1 Block diagram..... 19

5.3.2 Value ranges for system components:..... 21

5.3.3 Limitations on ripple current 21

5.3.4 Test methods..... 23

5.3.5 Ripple current in case of MCS 24

5.3.6 Limited operation of source-load(s) combinations with respect to ripple currents 25

5.3.7 Energy feedback 25

Company Use

5.3.8 Functional requirements — Energy feedback over time25
5.4 Overload protection26
Annex A (informative) Estimation methods for DC link film capacitors27
Annex B (informative) Technical details30
Bibliography45

~~Foreword~~4

~~1 Scope~~5

~~2 Normative references~~6

~~3 Terms and definitions~~7

~~4 System Overview~~12

~~4.1 Operation with single CS~~13

~~4.2 Operation with MCS~~14

~~5 DC specification~~18

~~5.1 Voltage Form and Quality~~18

~~5.1.1 System voltage: values and ranges~~18

~~5.1.2 Voltage Ripple~~19

~~5.1.3 Continuous DC Current~~19

~~5.1.4 Peak Current~~19

~~5.1.5 Current specific communication parameters~~20

~~5.1.6 Voltage dips and Recovery Time~~20

~~5.1.7 Overvoltage Protection~~20

~~5.1.8 Overcurrent Protection~~21

~~5.1.9 System inductance~~23

~~5.1.10 DC link capacitance~~23

~~5.1.11 Y-Capacitors, Parasitic Capacitances~~23

~~5.1.12 DC Link Pre-charging~~23

~~5.2 DC link discharging procedure~~25

~~5.2.1 Connection of MCS~~26

~~5.3 Compatibility Criteria for PS, HPI and Load~~26

~~5.3.1 Block Diagram~~26

~~5.3.2 Value ranges for system components~~27

~~5.3.3 Limitations on ripple current~~28

~~5.3.4 Test methods~~29

~~5.3.5 Ripple current in case of MCS~~30

~~5.3.6 Limited operation of source load(s) combinations with respect to ripple currents~~31

~~5.3.7 Energy feedback~~31

~~Edited DIS -
MUST BE USED
FOR FINAL
DRAFT~~

Company Use

© ISO 2022 - All rights reserved

© ISO 2023 - All rights reserved

FINAL STANDARD PREVIEW
(standards.iteh.ai)

ISO 23316-5

standards.iteh.ai/catalog/standards/sist/4ce0b81d-506b-4750-9c06-9265983d0d8c/iso-23316-5

5.3.8	Functional Requirements – Energy Feedback over Time	32
5.4	Overload protection	32
Annex A (informative) Estimation methods for DC link film capacitors		34
A.1.1	Minimum DC Link System Capacitance	34
A.1.1.1	Minimum DC link capacitance (film capacitors)	34
A.1.2	Minimum DC link capacitance: alternative calculation method	34
Annex B (informative)		36
B.1	Calculation of cable inductance	36
B.2	Reforming of electrolytic capacitors	37
B.3	Example: Pre-charge state machine	38
B.4	Simplified circuit diagrams describing various operational modes	39
B.4.1	Normal Operation (connected, no energy feedback)	39
B.4.2	Operation with Energy Feedback by CS	40
B.4.3	Pre-charge Operation	40
B.4.4	“Normal” Discharge Operation (No Emergency Discharge)	41
B.4.5	“Normal” Discharge Operation (CS only)	42
B.4.6	Diagrams containing EMC measures	42
B.4.7	“Sophisticated Model”	43
B.5	Considerations of Cable Length in a VC-B2 System	44
B.6	DC bus filters	44
B.6.1	Limits on switching frequencies	45
B.7	Using the i_{zt} value for overload protection	45

Company Use

© ISO 2022 – All rights reserved

© ISO 2023 – All rights reserved

Foreword

ISO (the International Organization for Standardization) is a worldwide federation of national standards bodies (ISO member bodies). The work of preparing International Standards is normally carried out through ISO technical committees. Each member body interested in a subject for which a technical committee has been established has the right to be represented on that committee. International organizations, governmental and non-governmental, in liaison with ISO, also take part in the work. ISO collaborates closely with the International Electrotechnical Commission (IEC) on all matters of electrotechnical standardization.

The procedures used to develop this document and those intended for its further maintenance are described in the ISO/IEC Directives, Part-1. In particular, the different approval criteria needed for the different types of ISO documents should be noted. This document was drafted in accordance with the editorial rules of the ISO/IEC Directives, Part-2 (see www.iso.org/directives).

~~Attention is drawn to the possibility that some of the elements of this document may be the subject of a patent rights. ISO takes no position concerning the evidence, validity or applicability of any claimed patent rights in respect thereof. As of the date of publication of this document, ISO had received notice of (a) patent(s) which may be required to implement this document. However, implementers are cautioned that this may not represent the latest information, which may be obtained from the patent database available at www.iso.org/patents. ISO shall not be held responsible for identifying any or all such patent rights. Details of any patent rights identified during the development of the document will be in the Introduction and/or on the ISO list of patent declarations received (see www.iso.org/patents).~~

Any trade name used in this document is information given for the convenience of users and does not constitute an endorsement.

For an explanation of the voluntary nature of standards, the meaning of ISO specific terms and expressions related to conformity assessment, as well as information about ISO's adherence to the World Trade Organization (WTO) principles in the Technical Barriers to Trade (TBT), see www.iso.org/iso/foreword.html.

This document was prepared by Technical Committee ISO/TC 23, *Tractors and machinery for agriculture and forestry*, Subcommittee SC 19, *Agricultural electronics*.

A list of all parts in the ISO 23316 series can be found on the ISO website.

Any feedback or questions on this document should be directed to the user's national standards body. A complete listing of these bodies can be found at www.iso.org/members.html.

Field Code Changed

~~Edited DIS -
MUST BE USED
FOR FINAL
DRAFT~~

Introduction

ISO 23316-1 describes the general purpose and structure of standards in the ISO 23316 series, including common elements and definitions shared within all parts of the ISO 23316 series.

The purpose of the ISO 23316 series is to provide design and application standards covering implementation of electrical high power interface with a nominal voltage of ~~700VDC/480VAC~~ 700 VDC/480 VAC for agricultural and forestry machinery.

The ISO 23316 series specifies physical and logical interface requirements that provide interoperability and cross compatibility for systems and equipment operating at nominal voltages of ~~700VDC/480VAC~~ 700 VDC/480 VAC.

The following are not within the scope of ISO 23316:

- ~~Service~~ service, maintenance, and related diagnostics;
- ~~Functional~~ functional safety;
- ~~Control~~ control strategies for high power sources and loads;
- ~~Application~~ application-specific strategies and operational modes;
- ~~Component~~ component design;
- ~~Energy~~ energy storage systems, e. g. super-capacitors or batteries;
- ~~Multiple~~ multiple electrical power sources supplying a common DC link.

It is permitted for partial systems or components to be compliant to the ISO 23316 series by applying all applicable requirements, e.g. for the plug, receptacle or inverters, on a tractor or implement.

~~Note: e.g. if~~ NOTE If a DC-mode only HPI is provided, it is not necessary to comply with part 4 describing AC-mode, as it is not applicable. If an AC-mode only HPI is provided, it is not necessary to comply with ~~part 5 describing DC-mode~~ part 5 describing DC-mode ~~this document~~, as it is not applicable.

Tractors and machinery for agriculture and forestry — Electrical high-power interface 700 V DC / 480 V AC —

Part 5: DC operation mode

~~IMPORTANT — The electronic file of this document contains colours which are considered to be useful for the correct understanding of the document. Users should therefore consider printing this document using a colour printer~~

4.1 Scope

This document specifies measures applicable to the class B2 voltage DC bus of a supply system which is intended to power detachable electrical CS(s).

- ~~Electrical~~electrical specification of the high power interface
- ~~Operating~~operating modes (e. g. initialization, normal operation, energy feedback, connect/disconnect procedures and disconnect in case of malfunction)
- ~~Communication~~communication parameters (basic framework: signals, ranges, units, states of supply system and CS)

The document contains simplified electrical diagrams showing specific aspects of the required functionality.

5.2 Normative references

The following documents are referred to in the text in such a way that some or all of their content constitutes requirements of this document. For dated references, only the edition cited applies. For undated references, the latest edition of the referenced document (including any amendments) applies.

ISO 16230-1:2015, *Agricultural machinery and tractors — Safety of higher voltage electrical and electronic components and systems — Part 1: General requirements*

ISO 23316-1, *Tractors and machinery for agriculture and forestry — Electrical high-power interface 700 V DC / 480 V AC — Part 1: General description*

ISO 23316-2, *Tractors and machinery for agriculture and forestry — Electrical high power interface 700 V DC / 480 V AC — Part 2: Physical interface*

ISO 23316-3, *Tractors and machinery for agriculture and forestry — Electrical high power interface 700 V DC / 480 V AC — Part 3: Safety requirements*

ISO/DIS 23316-6-1, *Tractors and machinery for agriculture and forestry — Electrical high power interface 700 V DC / 480 V AC — Part 6: Controls communication*

¹ Under preparation. Stage at the date of publication: ISO/DIS 23316-6:2023.

6.3 Terms, definitions and symbols

6.3.1 Terms and definitions

For the purposes of this document, the terms and definitions given in ISO 23316-series-1, ISO/DIS 23316-6:— and the following apply.

ISO and IEC maintain terminology databases for use in standardization at the following addresses:

- ISO Online browsing platform: available at <https://www.iso.org/obp>
- IEC Electropedia: available at <https://www.electropedia.org/>

3.1.1 device under test DUT

single component or combination of components as defined to be tested

[SOURCE: ISO 10605:2008, 3.3]

6.3.2 Symbols

$C_{DC,src}$	DC link capacitance PS
$C_{DC,ld}$	DC link capacitance CS
$C_{y,ld}$	Y-Capacitor CS
$C_{y,src}$	Y-Capacitor PS
L_{cab}	cable inductance
$L_{i,src}$	inner source inductance
$R_{i,src}$	inner source resistance
R_{cab}	cable resistance
R_{cont}	contact resistance

m inverter modulation index representing the amplitude of the fundamental output voltage U_0 normalized by the DC supply voltage U_{DC} , so $m = U_0/U_{DC}$

ΔU voltage ripple

C_{DC} DC link capacitor

I_{pk} peak current

I_{rms} root mean square current

f_{sw} switching frequency

min minimum

STANDARD PREVIEW
(standards.iteh.ai)

ISO 23316-5

standards.iteh.ai/catalog/standards/sist/4ce0b81d-506b-4750-9c06-9265983d0d8c/iso-23316-5

~~Edited DIS -
MUST BE USED
FOR FINAL
DRAFT~~

Company Use

© ISO 2022 - All rights reserved

© ISO 2023 - All rights reserved

7.4 System overview

7.4.1 General

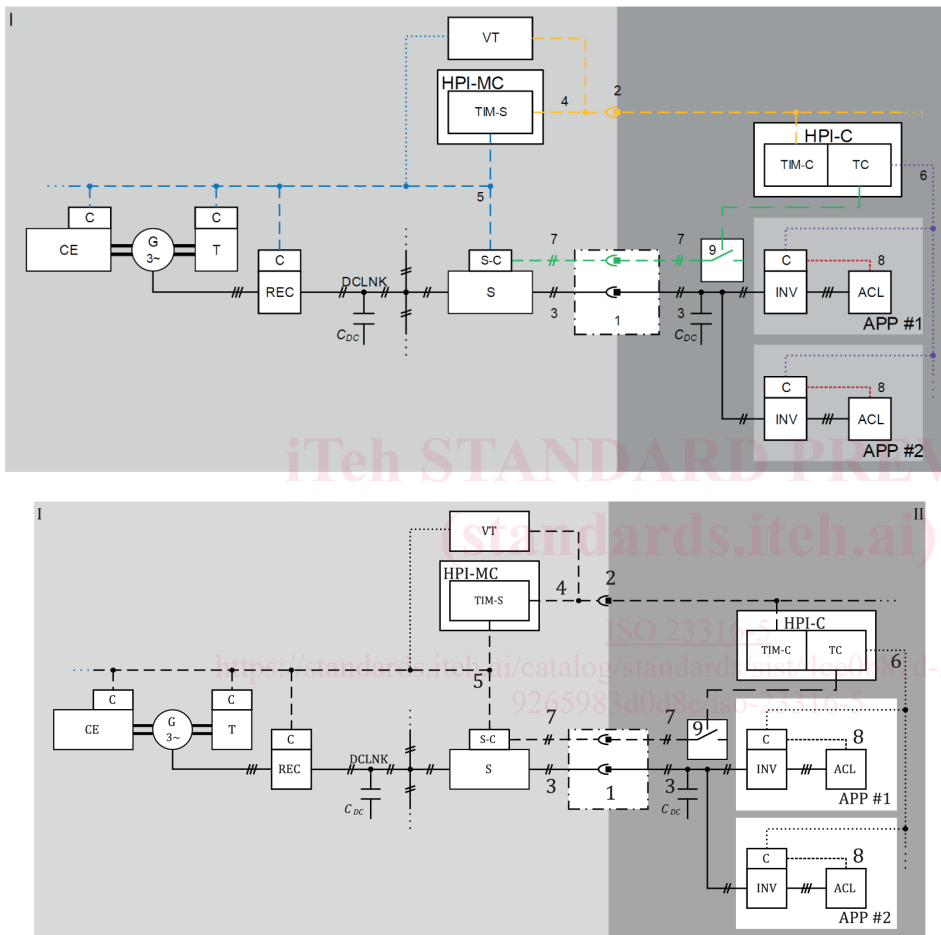

Key	
ACL	AC load (e.g. electric motor)
APP	Application/application
C	Controller/controller of a device
C _{DC}	DC link capacitor
CE	Combustion Engine/combustion engine
DCLNK	DC link
G	Generator/generator (as example of an electric power source)
HPI-C	High Power Interface - Control
HPI-MC	High Power Interface - Master Control

Company Use

© ISO 2022 – All rights reserved

© ISO 2023 – All rights reserved

ISO/DISPRF 23316-5:2022/2023(E)

INV	Inverter inverter (DC/AC converter)
REC	Rectifier rectifier (AC/DC power converter)
S	Switch switch (contactor or solid state switch, including pre- and discharge unit)
S-C	Switch Controller switch controller
T	Transmission transmission
TC	Task Controller task controller
TIM-C	TIM (Tractor Implement Management) Client
TIM-S	TIM Tractor Implement Management Server
VT	Virtual Terminal virtual terminal (user interface, e.g. display)
I	Supply supply system
II	Consumer consumer system
1	high power interface
2	ISOBUS connector
3	power lines
4	ISOBUS
5	supply system communication bus (e.g. tractor bus)
6	consumer system communication bus (e.g. implement bus)
7	interlock signal
8	feedback signal (by e.g. a sensor)
9	interlock signal line breaker

Solid line power connection

Dashed line signal-/bus connection

Dotted line optional connection

Bold solid line defines focus of document

ITeH STANDARD PREVIEW
(standards.iteh.ai)

ISO 23316-5

ps://standards.iteh.ai/catalog/standards/sist/4ce0b81d-506b-4750-9c06-9265983d0d8c/iso-23316-5

Figure 1.— Exemplary system schematics

The system consists at least of an electrical PS with generator and control providing DC power on a DC link and a CS, which is connected by an HPI and communication line in accordance with ISO/DIS 23316-6:—. System schematics are shown in ~~Figure 1.~~Figure 1.

NOTE 1 Depending on design, ~~for implements~~a discharge unit can be needed.~~for implements.~~

The architecture of the load depends upon the specific application and can have any combination of resistive, inductive and capacitive elements. The common base is the voltage provided by the source (and specified in the subsequent chapters) and the communication interface according to ISO/DIS 23316-6:—. A voltage source can have multiple HPIs.

The minimum VC-B2 system consists of at least one PS and one APP. The VC-B2 system is based on an IT system. Each implement may contain many different VC-B2 devices.

NOTE 2 Pre-/Discharge procedures, disconnect devices and filters are described in subsequent sections.

4 ~~Company Use~~ © ISO 2022 – All rights reserved

4 ~~DRAFT~~ © ISO 2023 – All rights reserved

7.4.2 Operation with single CS

At the simplest level, only one CS (e.g. implement) is attached on the supply system (e.g. tractor), where the PS is located. The single CS can contain one or more independent VC-B2 devices. Such a configuration is shown in Figure 2 and is the basis for the following figures with MCS.

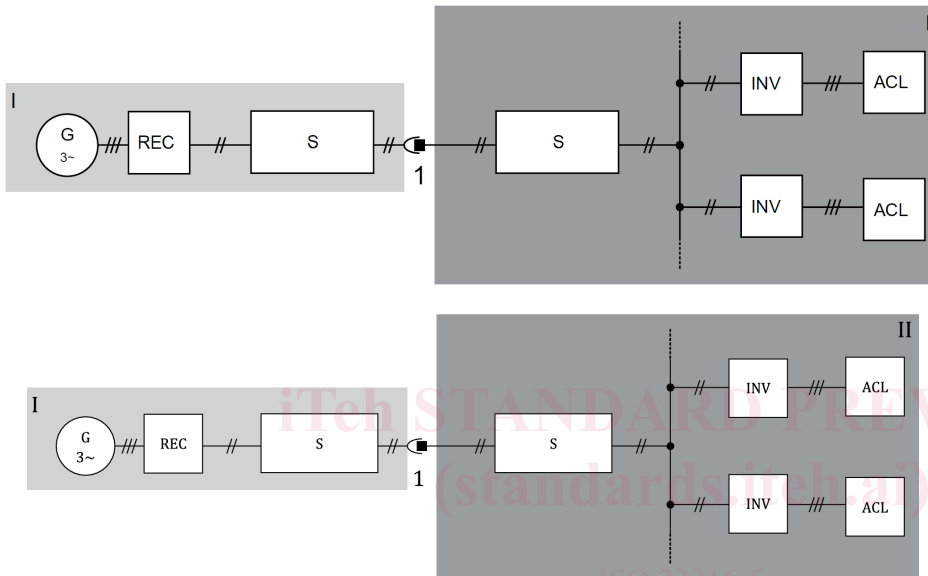

- Key**
- ACL AC Load (e.g. electric motor)
 - G Generator
 - INV Inverter
 - REC Rectifier
 - S Pre- / discharge / disconnecting device
 - I Supply System (e.g. tractor)
 - II Consumer System (e.g. implement)
 - 1 high power interface

Figure 2.— Single implement block diagram

7.4.3 Operation with MCS

It is also possible to attach an MCS to a supply system (e.g. tractor). Each can contain one, or more VC-B2 devices. If an MCS is attached to one supply system, each CS needs its own HPI-C. The following figures show some, but not all possible, configurations.

The first supply system in the topology (typically located on tractor, or a PTO generator) shall provide the sum of the power of the connected CS. In case of power/current restrictions due to higher total demand compared to capabilities, one of these two load balancing options shall be used.

- a) 1) The HPI-MC shall control the power distribution of all other connected combinations.

Company Use

© ISO 2022 – All rights reserved

© ISO 2023 – All rights reserved

- b) ~~2)~~ The HPI-MC shall control the power distribution of the first supply system connected subsystems (which consist of several VC-B2 devices).

~~Figure 3~~ Figure 3 shows a configuration where several CS are attached on supply system, and each has its own HPI (maximum allowed number of implements in accordance with ISO 11783).

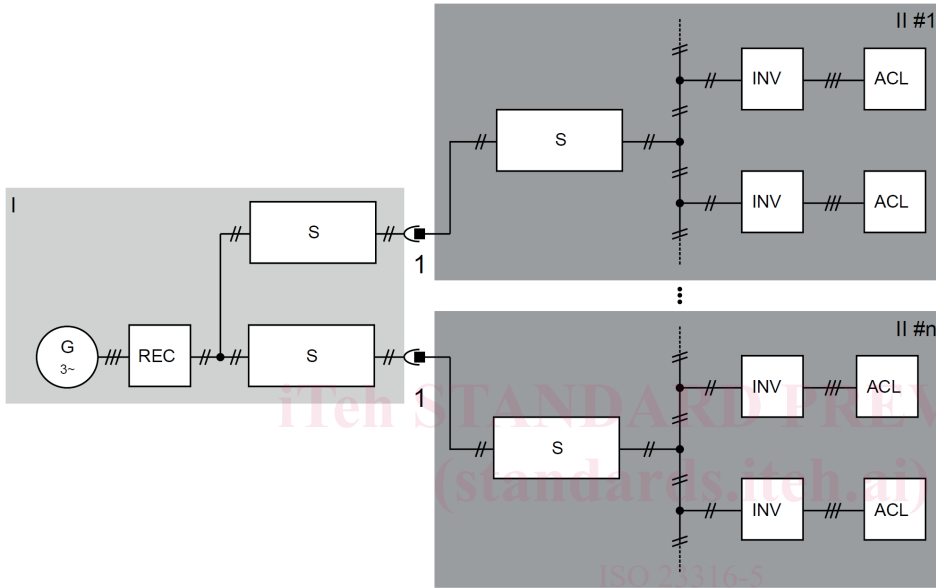

<https://standards.iteh.ai/catalog/standards/sist/4ce0b81d-506b-4750-9c06-9265983d0d8c/iso-23316-5>

~~Edited DIS -
MUST BE USED
FOR FINAL
DRAFT~~

Company Use

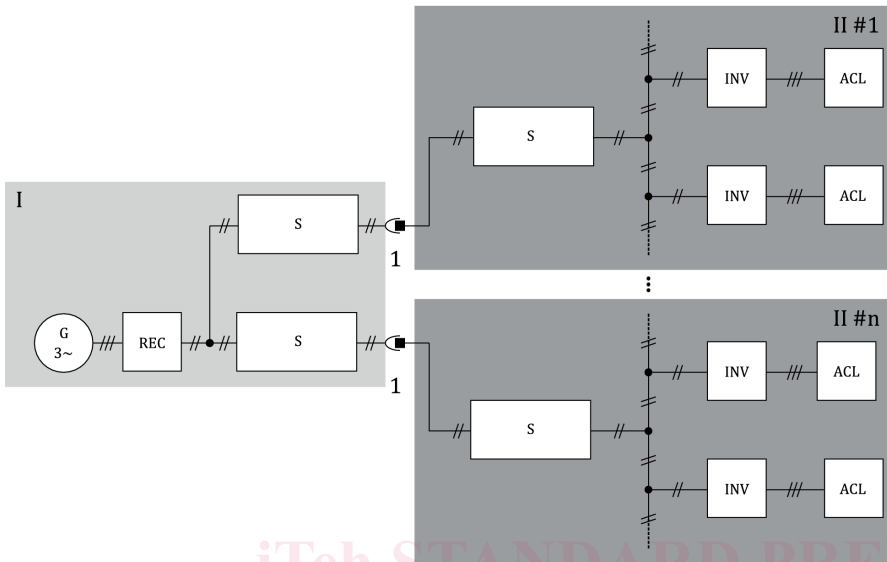

- Key**
- ACL AC Loadload (e.g. electric motor)
 - G Generatorgenerator
 - INV Inverterinverter
 - REC Rectifierrectifier
 - S Pre-/pre-/discharge-/disconnecting device
 - I Supply Systemsupply system (e.g. tractor)
 - II Consumer Systemconsumer system (e.g. implement)
 - 1 high power interface

Figure 3_ — Configuration with several parallel CS each at a separate connector

Figure 4 shows a configuration where a CS is attached on supply system's front and several CS are attached on supply system's rear and each has its own HPI.

Company Use