

Designation: G91 – 11

# Standard Practice for Monitoring Atmospheric SO<sub>2</sub> Deposition Rate for Atmospheric Corrosivity Evaluation<sup>1</sup>

This standard is issued under the fixed designation G91; the number immediately following the designation indicates the year of original adoption or, in the case of revision, the year of last revision. A number in parentheses indicates the year of last reappraisal. A superscript epsilon (ε) indicates an editorial change since the last revision or reappraisal.

## 1. Scope

1.1 This practice covers two methods of monitoring atmospheric sulfur dioxide, SO<sub>2</sub> deposition rates with specific application for estimating or evaluating atmospheric corrosivity as it applies to metals commonly used in buildings, structures, vehicles and devices used in outdoor locations.

1.2 The values stated in SI units are to be regarded as standard. No other units of measurement are included in this standard.

1.3 *This standard does not purport to address all of the safety concerns, if any, associated with its use. It is the responsibility of the user of this standard to establish appropriate safety and health practices and determine the applicability of regulatory limitations prior to use.*

## 2. Referenced Documents

### 2.1 ASTM Standards:<sup>2</sup>

D516 Test Method for Sulfate Ion in Water

D1193 Specification for Reagent Water

D2010/D2010M Test Methods for Evaluation of Total Sulfation Activity in the Atmosphere by the Lead Dioxide Technique

G16 Guide for Applying Statistics to Analysis of Corrosion Data

G84 Practice for Measurement of Time-of-Wetness on Surfaces Exposed to Wetting Conditions as in Atmospheric Corrosion Testing

G140 Test Method for Determining Atmospheric Chloride Deposition Rate by Wet Candle Method

G193 Terminology and Acronyms Relating to Corrosion

### 2.2 ISO Standards:<sup>3</sup>

ISO 9225 Corrosion of metals and alloys- Corrosivity of atmospheres – Measurement of environmental parameters affecting corrosivity of atmospheres

## 3. Terminology

3.1 *Definitions*—The terminology used herein shall be in accordance with Terminology and Acronyms G193.

## 4. Summary of Practice

4.1 Sulfation plates consisting of a lead peroxide reagent in an inverted dish are exposed for 30-day intervals. The plates are recovered and sulfate analyses performed on the contents to determine the extent of sulfur capture. Lead peroxide cylinders are also used for monitoring atmospheric SO<sub>2</sub> in a similar manner. The results are reported in terms of milligrams of SO<sub>2</sub> per square metre per day.

## 5. Significance and Use

5.1 Atmospheric corrosion of metallic materials is a function of many weather and atmospheric variables. The effect of specific corrodants, such as sulfur dioxide, can accelerate the atmospheric corrosion of metals significantly. It is important to have information available for the level of atmospheric SO<sub>2</sub> when many metals are exposed to the atmosphere in order to determine their susceptibility to corrosion damage during their life time in the atmosphere.

5.2 Volumetric analysis of atmospheric SO<sub>2</sub> concentration carried out on a continuous basis is considered by some investigators as the most reliable method of estimating the effects caused by this gas. However, these methods require sophisticated monitoring

<sup>1</sup> This practice is under the jurisdiction of ASTM Committee G01 on Corrosion of Metals and is the direct responsibility of Subcommittee G01.04 on Atmospheric Corrosion.

Current edition approved Nov. 1, 2011. Published December 2011. Originally approved in 1986. Last previous edition approved in 2010 as G91–97(2010). DOI: 10.1520/G0091-11.

<sup>2</sup> For referenced ASTM standards, visit the ASTM website, [www.astm.org](http://www.astm.org), or contact ASTM Customer Service at [service@astm.org](mailto:service@astm.org). For *Annual Book of ASTM Standards* volume information, refer to the standard's Document Summary page on the ASTM website.

<sup>3</sup> Available from International Organization for Standardization (ISO), 1, ch. de la Voie-Creuse, CP 56, CH-1211 Geneva 20, Switzerland, <http://www.iso.org>.

devices together with power supplies and other equipment that make them unsuitable for many exposure sites. These methods are beyond the scope of this practice.

5.3 The sulfation plate method provides a simple technique to independently monitor the level of SO<sub>2</sub> in the atmosphere to yield a weighted average result. The lead peroxide cylinder is similar technique that produces comparable results, and the results are more sensitive to low levels of SO<sub>2</sub>.

5.4 Sulfation plate or lead peroxide cylinder results may be used to characterize atmospheric corrosion test sites regarding the effective average level of SO<sub>2</sub> in the atmosphere at these locations.

5.5 Either sulfation plate or lead peroxide cylinder testing is useful in determining microclimate, seasonal, and long term variations in the effective average level of SO<sub>2</sub>.

5.6 The results of these sulfur dioxide deposition rate tests may be used in correlations of atmospheric corrosion rates with atmospheric data to determine the sensitivity of the corrosion rate to SO<sub>2</sub> level.

5.7 The sulfur dioxide monitoring methods may also be used with other methods, such as Practice G84 for measuring time of wetness and Test Method G140 for atmospheric chloride deposition, to characterize the atmosphere at sites where buildings or other construction is planned in order to determine the extent of protective measures required for metallic materials.

## 6. Interferences

6.1 The lead peroxide reagent used in the sulfation plates or lead peroxide cylinders may convert other sulfur containing compounds such as mercaptans, hydrogen sulfide, and carbonyl sulfide into sulfate.

NOTE 1—Hydrogen sulfide and mercaptans, at concentrations which affect the corrosion of structural metals significantly, are relatively rare in most atmospheric environments, but their effects regarding the corrosion of metals are not equivalent to sulfur dioxide. Therefore, if H<sub>2</sub>S, COS, or mercaptans are present in the atmosphere, that is, the odor of rotten eggs is present, the lead peroxide method must not be used to assess atmospheric corrosivity. It should also be noted that no actual measurements have been made which would establish the correlation between atmospheric H<sub>2</sub>S, COS, or mercaptan level and sulfation as measured by this practice.

6.2 The inverted exposure position of the sulfation plate is intended to minimize capture of sulfuric acid aerosols and sulfur bearing species from precipitation. The lead peroxide cylinder method may be more susceptible to capturing sulfuric acid aerosol particles. However, it should be noted that such aerosols are rare in most natural environments.

## 7. Preparation of SO<sub>2</sub> Deposition Monitoring Devices

7.1 Sulfation plates can be prepared according to the method of Huey.<sup>4</sup> The plate preparation method is given in Appendix X1. Laboratory prepared plates should be exposed within 120 days of preparation.

7.2 Lead peroxide cylinders can be prepared as shown in ISO 9225. The cylinder preparation procedure is also shown in Appendix X2. Lead peroxide cylinders should be exposed within 120 days of their preparation, and if stored they should be kept in a cool dry location.

## 8. Exposure of SO<sub>2</sub> Monitoring Devices

8.1 In general, the level of atmospheric sulfur dioxide varies seasonally during the year so that a minimal exposure program requires four 30-day exposures each year at roughly equal intervals. In order to establish the atmospheric SO<sub>2</sub> level at an atmospheric corrosion test site which has not been monitored previously, a program in which six 30-day exposures per year for a period of 3 years is recommended. More extensive testing may be desirable if large variability is encountered in the results. Thereafter, the location should be monitored with at least four tests in a 1-year period every 3 years. If the subsequent tests are not consistent with the initial testing, then another 3-year program of six tests per year is required. Also, if a major change in the general area occurs in terms of industrial or urban development, then six tests per year for 3 years should again be carried out.

8.2 In monitoring exposure sites, a minimum of four plates or two cylinders shall be used for each exposure period.

8.2.1 Sites which have a significant grade or elevation variation should be monitored with at least two plates or one cylinder at the highest elevation and two plates or one cylinder at the lowest elevation.

8.2.2 Plates and cylinders should be exposed, if possible, at both the highest and lowest level above the ground at which corrosion test specimens are exposed.

8.2.3 Sites larger than 10 000 m<sup>2</sup> shall have at least eight plates or four cylinders exposed for each period. In rectangular sites on level ground, it is desirable to expose two plates or one cylinder at each corner.

NOTE 2—Some investigators have reported significantly higher sulfation results at locations closest to the ground.

### 8.3 Installation:

8.3.1 Brackets shall be used to hold the sulfation plates securely in an inverted position so that the lead peroxide mixture faces downward. The plate shall be horizontal and shall be placed so that it is not protected from normal winds and air currents. The bracket design should include a retaining clip or other provision to hold the plate in the event of strong winds. The retainer clip may be made from stainless steel, spring bronze, hard aluminum alloy (3003H19), or other alloys with sufficient strength and atmospheric corrosion resistance. A typical bracket design is shown in Fig. 1.

<sup>4</sup> Huey, N. A., "The Lead Dioxide Estimation of Sulfur Dioxide Pollution," *Journal of the Air Pollution Control Association*, Vol 18, No. 9, 1968, pp. 610–611.

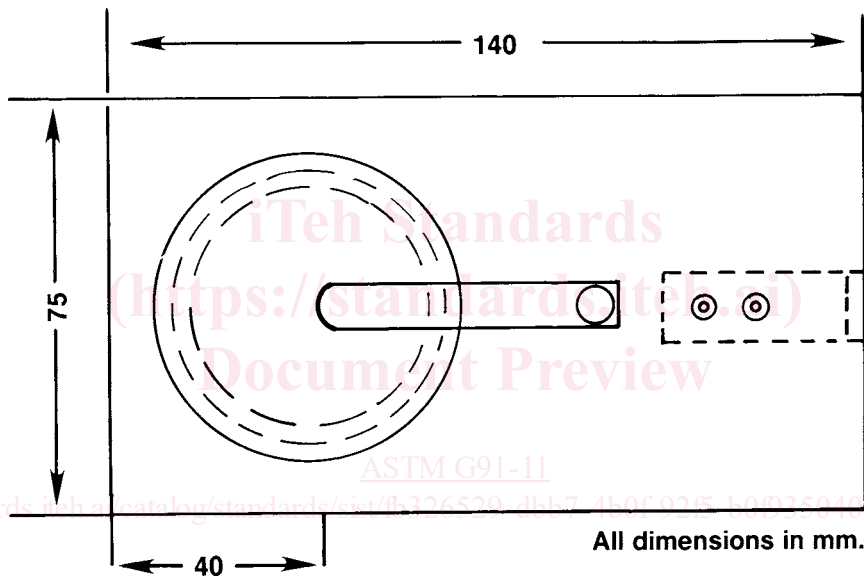
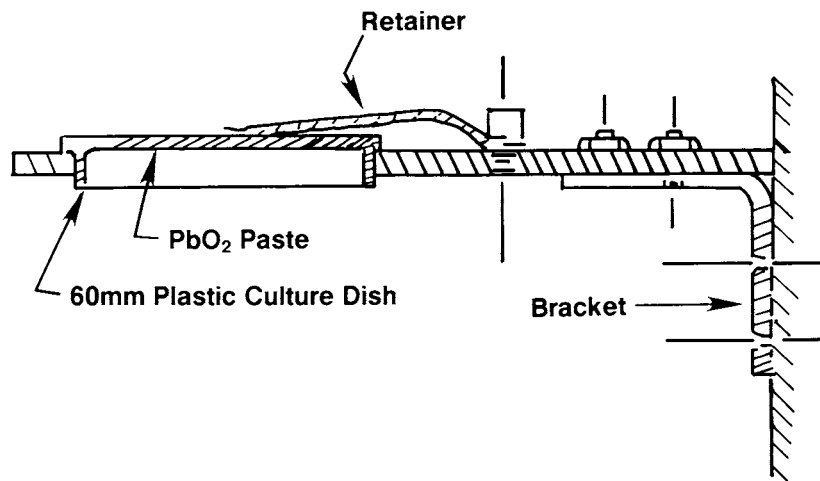

FIG. 1 Sulfation Plate Holder

8.3.2 For lead peroxide cylinders, each device shall be exposed in a support similar to that shown in Test Method G140 for chloride candles. Each cylinder shall be securely mounted in a vertical position with a clamp or other device to hold it securely against wind or other mechanical forces. A cover at least 300 mm in diameter shall be securely mounted above each cylinder with a clearance of 200 mm between the top on the cylinder and the bottom of the cover. The cover may also be rectangular or square with a minimum size of 300 mm for the smallest dimension. The stand and cover assembly should be constructed of materials that are not degraded by atmospheric exposure for the expected duration of their service.

8.4 A  $30 \pm 2$ -day exposure period is recommended for either the plates or cylinders. At the conclusion of this period, the device shall be removed from the bracket or holder and covered tightly to prevent additional sulfation. Analysis of the specimens shall be completed within 60 days of the completion of the exposure. The specimen identification, exposure location, and exposure initiation date should be recorded when the plate exposure is initiated. At the termination of exposure, the completion date should be added to the exposure records.

NOTE 3—The 30-day exposure is not very discriminating in areas of low  $\text{SO}_2$  concentrations. Experience has shown that 60- to 90-day exposure may be necessary to develop a measurable  $\text{SO}_2$  capture on the plate.

8.5 The specimen shall be analyzed for sulfate content using any established quantitative analysis technique.

NOTE 4—In conducting the sulfate analysis, it is necessary to remove the contents of the sulfation plate and solubilize the sulfate, for example, using a solution of sodium carbonate. It has been found that 20 mL of 50 g/L  $\text{Na}_2\text{CO}_3$  (ACS reagent grade) is sufficient to solubilize the sulfate in this test method in a 3-h period. Thereafter, conventional sulfate analysis can be employed, for example, by barium precipitation and either gravimetric or turbidimetric analysis (see Test Method D516).