



Designation: ~~D 3999–91~~(Reapproved 1996) Designation: D3999 – 11

## Standard Test Methods for the Determination of the Modulus and Damping Properties of Soils Using the Cyclic Triaxial Apparatus<sup>1</sup>

This standard is issued under the fixed designation D3999; the number immediately following the designation indicates the year of original adoption or, in the case of revision, the year of last revision. A number in parentheses indicates the year of last reapproval. A superscript epsilon ( $\epsilon$ ) indicates an editorial change since the last revision or reapproval.

### 1. Scope\*

1.1 These test methods cover the determination of the modulus and damping properties of soils in either ~~undisturbed~~ intact or reconstituted states by either load or stroke controlled cyclic triaxial techniques. The standard is focused on determining these properties for soils in hydrostatically consolidated, undrained conditions.

1.2 The cyclic triaxial properties of initially saturated or unsaturated soil specimens are evaluated relative to a number of factors including: strain level, density, number of cycles, material type, ~~saturation,~~ and effective stress.

1.3 These test methods are applicable to both fine-grained and coarse-grained soils as defined by the unified soil classification system or by Classification ~~D 2487~~ D2487. Test specimens may be ~~undisturbed~~ intact or reconstituted by compaction in the laboratory.

1.4 Two test methods are provided for using a cyclic loader to determine the secant Young's modulus ( $E$ ) and damping coefficient ( $D$ ) properties for a soil specimen. The first test method (A) permits the determination of  $E$  and  $D$  using a constant load apparatus. The second test method (B) permits the determination of  $E$  and  $D$  using a constant stroke apparatus. The test methods are as follows:

1.4.1 *Test Method A*—This test method requires the application of a constant cyclic load to the test specimen. It is used for determining the secant Young's modulus and damping coefficient under a constant load condition.

1.4.2 *Test Method B*—This test method requires the application of a constant cyclic deformation to the test specimen. It is used for determining the secant Young's modulus and damping coefficient under a constant stroke condition.

1.5 The development of relationships to aid in interpreting and evaluating test results are left to the engineer or office requesting the test.

1.6 *Limitations*—~~There are certain limitations inherent in using cyclic triaxial tests to simulate the stress and strain conditions of a soil element in the field during an earthquake.~~ There are certain limitations inherent in using cyclic triaxial tests to simulate the stress and strain conditions of a soil element in the field during an earthquake, with several summarized in the following sections. With due consideration for the factors affecting test results, carefully conducted cyclic triaxial tests can provide data on the cyclic behavior of soils with a degree of accuracy adequate for meaningful evaluations of modulus and damping coefficient below a shearing strain level of 0.5 %.

1.6.1 Nonuniform stress conditions within the test specimen are imposed by the specimen end platens.

1.6.2 A 90° change in the direction of the major principal stress occurs during the two halves of the loading cycle on isotropically confined specimens ~~and at certain levels of cyclic stress application on anisotropically confined specimens.~~

1.6.3 The maximum cyclic axial stress that can be applied to a saturated specimen is controlled by the stress conditions at the end of confining stress application and the pore-water pressures generated during ~~testing, undrained compression.~~ For an isotropically confined specimen tested in cyclic compression, the maximum cyclic axial stress that can be applied to the specimen is equal to the effective confining pressure. Since cohesionless soils ~~are not capable of taking cannot resist~~ tension, cyclic axial stresses greater than this value tend to lift the top platen from the soil specimen. Also, as the pore-water pressure increases during tests performed on isotropically confined specimens, the effective confining pressure is reduced, contributing to the tendency of the specimen to neck during the extension portion of the load cycle, invalidating test results beyond that point.

1.6.4 While it is advised that the best possible ~~undisturbed~~ intact specimens be obtained for cyclic testing, it is sometimes necessary to reconstitute soil specimens. It has been shown that different methods of reconstituting specimens to the same density may result in significantly different cyclic behavior. Also, ~~undisturbed~~ intact specimens will almost always be stronger and stiffer than reconstituted specimens of the same density.

<sup>1</sup> These test methods are under the jurisdiction of ASTM Committee ~~D 18~~ D18 on Soil and Rock and are the direct responsibility of Subcommittee ~~D18.09~~ D18.09 on Dynamic Properties of Soils.

Current edition approved August 15, 1991. Published October 1991 on Cyclic and Dynamic Properties of Soils.

Current edition approved Nov. 1, 2011. Published January 2012. Originally approved in 1991. Last previous edition approved in 2003 as D3999–91(2003). DOI: 10.1520/D3999-11.

\*A Summary of Changes section appears at the end of this standard.

1.6.5 The interaction between the specimen, membrane, and confining fluid has an influence on cyclic behavior. Membrane compliance effects cannot be readily accounted for in the test procedure or in interpretation of test results. Changes in pore-water pressure can cause changes in membrane penetration in specimens of cohesionless soils. These changes can significantly influence the test results.

~~1.6.6 Despite these limitations, with due consideration for the factors affecting test results, carefully conducted cyclic triaxial tests can provide data on the cyclic behavior of soils with a degree of accuracy adequate for meaningful evaluations of modulus and damping below a shearing strain level of 0.5%.~~

~~1.7 The values stated in either SI or inch-pound units shall be regarded separately as standard. The values in each system may not be exact equivalents, therefore, each system must be used independently of the other, without combining values in any way.~~

1.7 The values stated in either SI units or inch-pound units [presented in brackets] are to be regarded separately as standard. The values stated in each system may not be exact equivalents; therefore, each system shall be used independently of the other. Combining values from the two systems may result in non-conformance with the standard. Reporting of test results in units other than SI shall not be regarded as nonconformance with this test method.

1.8 All observed and calculated values shall conform to the guide for significant digits and rounding established in Practice D6026. The procedures in Practice D6026 that are used to specify how data are collected, recorded, and calculated are regarded as the industry standard. In addition, they are representative of the significant digits that should generally be retained. The procedures do not consider material variation, purpose for obtaining the data, special purpose studies, or any considerations for the objectives of the user. Increasing or reducing the significant digits of reported data to be commensurate with these considerations is common practice. Consideration of the significant digits to be used in analysis methods for engineering design is beyond the scope of this standard.

1.8.1 The method used to specify how data are collected, calculated, or recorded in this standard is not directly related to the accuracy to which the data can be applied in design or other uses, or both. How one applies the results obtained using this standard is beyond its scope.

1.9 This standard does not purport to address all of the safety concerns, if any, associated with its use. It is the responsibility of the user of this standard to establish appropriate safety and health practices and determine the applicability of regulatory limitations prior to use.

## 2. Referenced Documents

### 2.1 ASTM Standards:<sup>2</sup>

D422 [Test Method for Particle-Size Analysis of Soils](#)

D653 [Terminology Relating to Soil, Rock, and Contained Fluids](#)

D854 [Test Method for Specific Gravity of Soils](#)<sup>2</sup> [Test Methods for Specific Gravity of Soil Solids by Water Pycnometer](#)

D1587 [Practice for Thin-Walled Tube Sampling of Soils for Geotechnical Purposes](#)

D2216 [Test Methods for Laboratory Determination of Water \(Moisture\) Content of Soil and Rock by Mass](#) ~~D3999-11~~

D2435 [Test Method for One-Dimensional Consolidation Properties of Soils](#)<sup>2</sup> [Test Methods for One-Dimensional Consolidation Properties of Soils Using Incremental Loading](#)

D2487 [Practice for Classification of Soils for Engineering Purposes \(Unified Soil Classification System\)](#)

D2488 [Practice for Description and Identification of Soils \(Visual-Manual Procedure\)](#)

D3740 [Practice for Minimum Requirements for Agencies Engaged in the Testing and/or Inspection of Soil and Rock as Used in Engineering Design and Construction](#)

D4220 [Practices for Preserving and Transporting Soil Samples](#)

D4318 [Test Methods for Liquid Limit, Plastic Limit, and Plasticity Index of Soils](#)

~~D4767 Test Method for Consolidated Undrained Triaxial Compression Test on Cohesive Soils~~<sup>2</sup> [Test Method for Consolidated Undrained Triaxial Compression Test for Cohesive Soils](#)

[D6026 Practice for Using Significant Digits in Geotechnical Data](#)

### 2.2 USBR Standard:

USBR 5210 [Practice for Preparing Compacted Soil Specimens for Laboratory Use](#)<sup>3</sup>

## 3. Terminology

### 3.1 Definitions:

3.1.1 The definitions of terms used in these test methods shall be in accordance with Terminology ~~D-653~~D653.

3.1.2 *back pressure*—a pressure applied to the specimen pore-water to cause air in the pore space to pass into solution in the pore-water, that is, to saturate the specimen.

### 3.2 Definitions of Terms Specific to This Standard:

<sup>2</sup> Annual Book of ASTM Standards, Vol 04.08.

<sup>3</sup> Available from U.S. Department of the Interior, Bureau of Reclamation.

3.2.1 *back pressure*—a pressure applied to the specimen pore-water to cause air in the pore space to pass into solution in the pore-water, that is, to saturate the specimen.

3.2.2 *cycle duration*—the time interval between successive applications of a deviator stress.

3.2.3

3.2.2 *deviator stress* [ $FL^{-2}$ ]—the difference between the major and minor principal stresses in a triaxial test.

3.2.4

3.2.3 *effective confining stress*—the confining pressure (the difference between the cell pressure and the pore-water pressure) prior to shearing the specimen.

3.2.5

3.2.4 *effective force, (F)*—the force transmitted through a soil or rock mass by intergranular pressures.

3.2.6

3.2.5 *hysteresis loop*—a trace of load versus deformation resulting from the application of one complete cycle of either a cyclic load or deformation. The area within the resulting loop is due to energy dissipated by the specimen and apparatus, see Fig. 1.

3.2.7

3.2.6 *load duration*—the time interval the specimen is subjected to a cyclic deviator stress.

3.2.8 *principal stress*—the stress normal to one of three mutually perpendicular planes on which the shear stresses at a point in a body are zero.

3.2.9 *Young's modulus (modulus of elasticity)* [ $FL^{-2}$ ]—the ratio of stress to strain for a material under given loading conditions; numerically equal to the slope of the tangent or the secant of a stress-strain curve (same as Terminology D 653D 653).

#### 4. Summary of Test Method

4.1 The cyclic triaxial test consists of imposing either a cyclic axial deviator stress of fixed magnitude (load control) or cyclic axial deformation (stroke control) on a cylindrical, hydrostatically consolidated soil specimen enclosed in a triaxial pressure cell, undrained conditions. The resulting axial strain and axial stress are measured and used to calculate either stress-dependent or stroke-dependent secant modulus and damping coefficient.

#### 5. Significance and Use

5.1 The cyclic triaxial modulus and damping test provides parameters that may be considered for use in dynamic, linear and non-linear analytical methods. These test methods are used for the performance evaluation of both natural and engineered structures under dynamic or cyclic loads such as caused by earthquakes, ocean wave, or blast.

5.2 One of the primary purposes of these test methods is to obtain data that are used to calculate Young's modulus.

5.1 The cyclic triaxial test permits determination of the secant modulus and damping coefficient for cyclic axial loading of a prismatic soil specimen in hydrostatically consolidated, undrained conditions. The secant modulus and damping coefficient from this test may be different from those obtained from a torsional shear type of test on the same material.

5.2 The secant modulus and damping coefficient are important parameters used in dynamic, performance evaluation of both natural and engineered structures under dynamic or cyclic loads such as caused by earthquakes, ocean wave, or blasts. These parameters can be used in dynamic response analyses including, finite elements, finite difference, and linear or non-linear analytical methods.

NOTE 1—The quality of the result produced by this standard is dependent on the competence of the personnel performing it, and the suitability of the equipment and facilities used. Agencies that meet the criteria of Practice D 3740D3740 are generally considered capable of competent and objective testing/sampling/inspection/etc. Users of this standard are cautioned that compliance with Practice D 3740D3740 does not in itself assure reliable results. Reliable results depend on many factors; Practice D 3740D3740 provides a means of evaluating some of those factors.

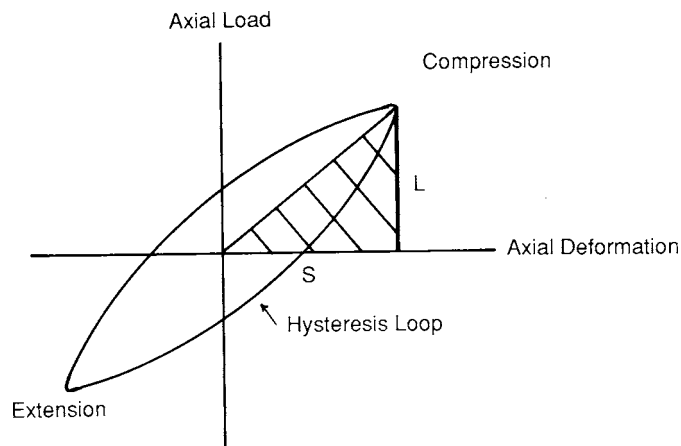

FIG. 1 Schematic of Typical Hysteresis Loop Generated by Cyclic Triaxial Apparatus

6. Apparatus

6.1 *General*—In many ways, triaxial equipment suitable for cyclic triaxial modulus and damping tests is similar to equipment used for the consolidated-undrained triaxial compression test (see Test Method D 4767). However, there are special features described in the following sections that are required to perform acceptable cyclic triaxial tests. A schematic representation of the various components comprising a typical cyclic triaxial modulus and damping test setup is shown in Fig. 2.

6.2 *Triaxial Pressure Cell*—The primary considerations in selecting the cell are tolerances for the piston, top platen, and low friction piston seal, *Cyclic Loading Equipment*:

6.2.1 Cyclic loading equipment used for load controlled cyclic triaxial tests must be capable of applying a uniform sinusoidal load at a frequency within the range of 0.1 to 2 Hz.

6.2.2 The equipment must be able to apply the cyclic load about an initial static load on the loading piston.

6.2.3 The loading device must be able to maintain uniform cyclic loadings to at least 0.5 % of the double amplitude stress, as defined in Fig. 3. The loading pattern used in this standard shall be harmonic, as shown in Fig. 4(a). Unacceptable loading patterns, such as unsymmetrical compression-extension load peaks, nonuniformity of pulse duration, “ringing,” or load fall-off at large strains are illustrated in Fig. 4(b) to Fig. 4(f). The loading pattern shall be compared to the tolerances shown in Fig. 4 to evaluate if it is acceptable for use in this standard.

6.2.4 Cyclic loading equipment used for deformation-controlled cyclic triaxial tests must be capable of applying a uniform sinusoidal deformation at a frequency range of 0.1 to 2 Hz. The equipment must also be able to apply the cyclic deformation about either an initial datum point or follow the specimen as it deforms. The type of apparatus typically employed can range from a simple cam to a closed loop electro-hydraulic system.

6.3 *Triaxial Pressure Cell*—The primary considerations in selecting the cell are tolerances for the piston, top platen, and low friction piston seal, as summarized in Fig. 5.

6.3.1 Two linear ball bushings or similar bearings should be used to guide the load rod loading piston to minimize friction and to maintain alignment.

6.3.2 The loading piston diameter should be large enough to minimize lateral bending. A minimum load rod loading piston diameter of 1/6 the specimen diameter has been used successfully in many laboratories.

6.3.3 The loading piston seal is a critical element in triaxial cell design for cyclic soils testing if an external load cell connected to the loading rod is employed. The seal must exert negligible friction on the load rod loading piston. The maximum acceptable piston friction tolerable without applying load corrections is commonly considered to be ±2 % of the maximum single amplitude cyclic load applied in the test, refer to Fig. 4.3. The use of a seal described in 9.16.4.8 and described by Ladd and Dutko,<sup>4</sup> and Chan and Chan<sup>5</sup> will meet these requirements.

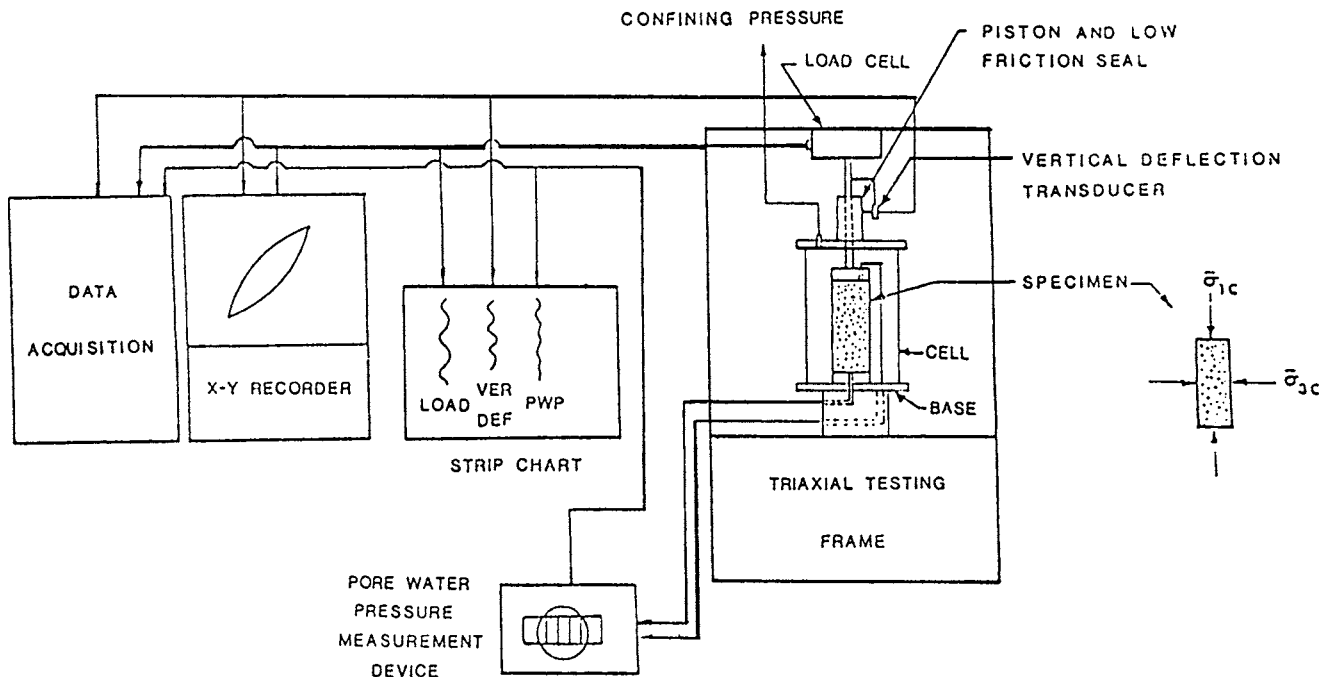
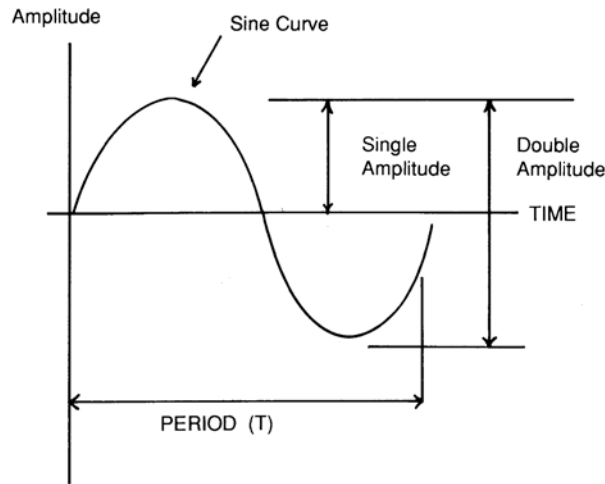

FIG. 2 Schematic Representation of Load or Stroke-Controlled Cyclic Triaxial Test Setup

<sup>4</sup> Ladd, R. S., and Dutko, P., “Small Strain Measurements Using Triaxial Apparatus,” *Advances In The Art of Testing Soils Under Cyclic Conditions*, V. Khosla, ed., American Society of Civil Engineers, 1985.

<sup>5</sup> Chan, C. K., “Low Friction Seal System” *Journal of the Geotechnical Engineering Division*, American Society of Civil Engineers, Vol. 101, GT-9, 1975, pp. 991–995.



**FIG. 3 Definitions Related to Cyclic Loading**  
(Frequency =  $1/\text{PERIOD} = 1/t$ )

6.2.4 Top and bottom platen alignment is critical to avoid increasing a nonuniform state of stress in the specimen. Internal tie-rod triaxial cells have worked well at a number of laboratories. These cells allow the placement of the cell wall after the specimen is in place between the loading platens. Acceptable limits on platen eccentricity and parallelism are shown in Fig. 56.

6.2.5 Since axial loading in cyclic triaxial tests is in extension as well as in compression, the load rod/loading piston shall be rigidly connected to the top platen by a method such as one of those shown in Fig. 67.

6.2.6 There shall be provision for specimen drainage at both the top and bottom platens.

#### 6.3 Cyclic Loading Equipment

6.3.6 There shall be provision for specimen drainage at both the top and bottom platens for saturation and consolidation of the specimen before cyclic loading.

#### 6.4 System Compliance:

6.3.1 Cyclic loading equipment used for load controlled cyclic triaxial tests must be capable of applying a uniform sinusoidal load at a frequency within the range of 0.1 to 2 Hz. The loading device must be able to maintain uniform cyclic loadings to at least 0.5% double amplitude stress, refer to Fig. 4. Unsymmetrical compression-extension load peaks, nonuniformity of pulse duration, “ringing”, or load fall-off at large strains must not exceed tolerances illustrated in

6.4.1 System—The compliance of the loading system, consisting of all parts (top platen, bottom platen, porous stones, connections) between where the specimen deformation shall be determined. This determination shall be under both tension and compressional loading.

6.4.2 Insert a dummy cylindrical specimen of a similar size and length to that being tested into the location normally occupied by the specimen. The secant Young’s modulus of the dummy specimen should be a minimum of ten times the secant modulus of the materials being tested. The ends of the dummy specimen should be flat and meet the tolerances for parallelism as shown in Fig. 6(b). Typical materials used to make dummy specimens are aluminum and steel. The dummy specimen should be rigidly attached to the loading system. This is typically accomplished by cementing the dummy specimen to the porous stones using either epoxy or hydro-cement or their equivalent. Allow cement to thoroughly dry before testing.

6.4.3 Typical top platen connections that have been employed are shown in Fig. 7. The equipment must also be able to apply the cyclic load about an initial static load on the loading rod.

6.3.2 Cyclic loading equipment used for deformation-controlled cyclic triaxial tests must be capable of applying a uniform sinusoidal deformation at a frequency range of 0.1 to 2 Hz. The equipment must also be able to apply the cyclic deformation about either an initial datum point or follow the specimen as it deforms. The type of apparatus typically employed can range from a simple cam to a closed loop electro-hydraulic system.

6.4. The purpose of the connection is to provide a rigid fastening that is easy to assemble. The hard lock systems (see Fig. 7(a)) are necessary for testing stiff materials but require the ability to tighten the nut with a wrench. If it is not possible to employ a wrench or if testing relatively soft materials, then either a magnetic system (see Fig. 7(b)) or vacuum system (see Fig. 7(c)) can be used.

6.4.4 Apply a static load in both tension and compression to the dummy specimen in increments up to two times the expected testing load and note the resulting deformation.

6.4.5 Use the maximum system deformation that occurs at any one load whether in tension or compression.

6.4.6 For any given loading whether in tension or compression, the minimum deformation that can be monitored and reported during an actual test is ten times the corresponding system deformation, see Note 2.

NOTE 2—Example calculation of system measurement compliance. A system deformation of 0.0001 mm is measured at a given load (either tension



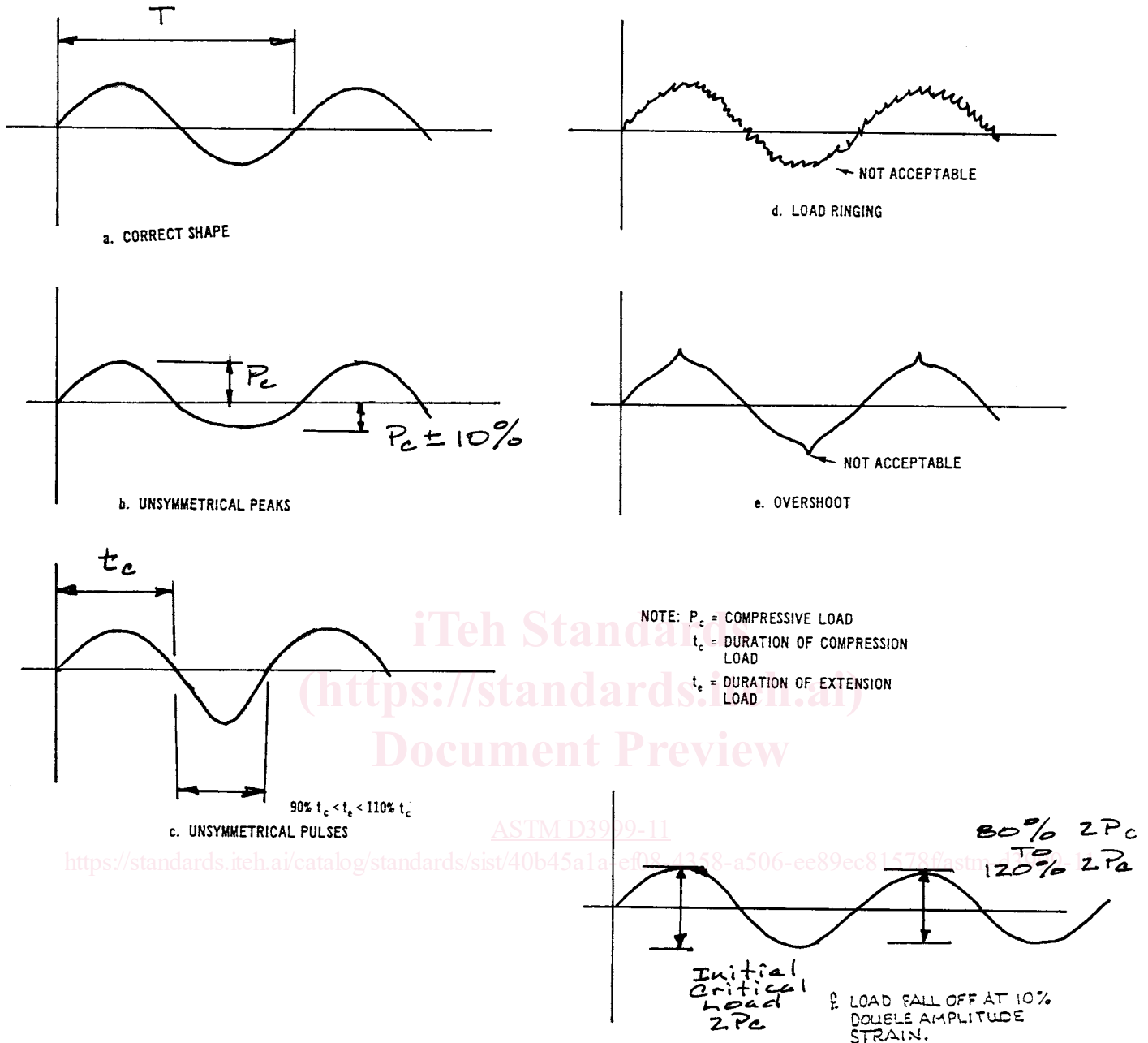

FIG. 7.4 Examples of Acceptable and Unacceptable Sinusoidal Loading Wave Forms For Cyclic Triaxial Load Control Tests

or compression) then the minimum system measuring compliance for a given load is ten times greater ( $0.0001 \text{ mm} \times 10 = 0.001 \text{ mm}$ ). Therefore if the actual specimen being tested has a height of 127 mm (5.0 in.), then the corresponding minimum axial strain ( $\epsilon_a$ ) that can be measured and reported with this system is the following:

$$\epsilon_a = \frac{0.001 \text{ mm}}{127 \text{ mm}} \times 100 \% = 7.9 \times 10^{-4} \% \text{ D3999-11}_1$$

6.4.7 *Compliance Between Specimen Cap and Specimen*—Compliance can be reduced by the following methods: achieving the final desired height of reconstituted specimens by tapping and rotating the specimen cap on top of the specimen, or for both reconstituted and intact specimens, fill voids between the cap and specimen with plaster of Paris, or similar porous material (refer to 7.3.3).

6.4.8 Two typical piston sealing arrangements employed in cyclic triaxial apparatus are shown in Fig. 8. Such arrangements are necessary if external load measurement devices are used. The linear bearing/O-ring seal is the most common, see Fig. 8. The primary difficulty with this seal is friction developed between the O-ring and the surface of the load piston. To reduce this friction two methods can be employed. These methods are over sizing the O-ring, and freezing the O-ring with electronic Freon spray then thawing out and chroming the load piston. The air bearing seal arrangement shown in Fig. 8 produces the minimum friction on

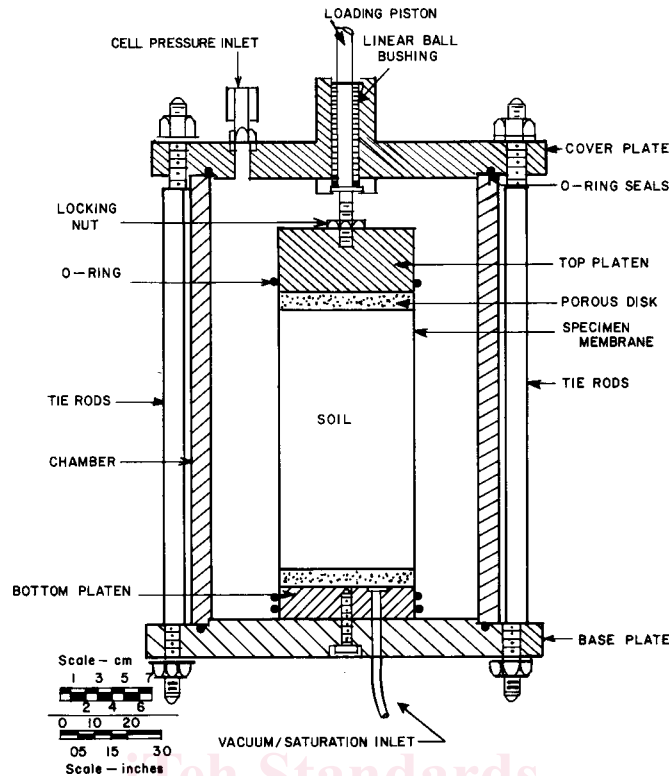

FIG. 3 5 Typical Cyclic Triaxial Pressure Cell

the load piston. The primary difficulty with this seal is the maintenance of the close tolerance between the slides and the load piston. Accumulation of dirt or salt tends to either block this zone or increase friction. Cleanliness is absolutely necessary for operation of this seal.

6.4.9 Triaxial cell designs to achieve requirements of platen alignment and reduce compliance are shown in Fig. 9.

6.4.10 The implication of poor system compliance on test results is illustrated in the hypothetical normalized secant modulus versus strain magnitude results shown in Fig. 10. Fig. 10 indicates that as the compliance increases in the cyclic triaxial test system the greater the deviation from the modulus values from a smaller strain test such as the resonant column test.

#### 6.5 Recording Equipment:

6.45.1 Load, displacement, and pore water pressure transducers are required to monitor specimen behavior during cyclic loading; provisions for monitoring the chamber pressure during cyclic loading are optional.

6.4.26.5.2 Load Measurement—Generally, the load cell capacity should be no greater than five times the total maximum load applied to the test specimen to ensure that the necessary measurement accuracy is achieved. The minimum performance characteristics of the load cell are presented in Table 1.

#### 6.4.3

6.5.3 Axial Deformation Measurement—Displacement measuring devices such as linear variable differential transformer (LVDT), Potentiometer-type deformation transducers, and eddy current sensors may be used if they meet the required performance criteria (see Table 1). Accurate deformation measurements require that the transducer be properly mounted to avoid excessive mechanical system compression between the load frame, the triaxial cell, the load cell, and the loading piston.

#### 6.4.4

6.5.4 Pressure- and Vacuum-Control Devices—The chamber pressure and back pressure control devices shall be capable of applying and controlling pressures to within  $\pm 2$  psi (14 kPa)  $\pm 14$  kPa (2 psi) for effective consolidation pressures. The vacuum control device shall be capable of applying and controlling partial vacuums to within  $\pm 2$  psi (14 kPa)  $\pm 14$  kPa (2 psi). The devices may consist of self-compensating mercury pots, pneumatic pressure regulators, combination pneumatic pressure and vacuum regulators, or any other device capable of applying and controlling pressures or partial vacuums to the required tolerances.

6.4.56.5.5 Pressure- and Vacuum-Measurement Devices—The chamber pressure, back pressure, and vacuum measuring devices shall be capable of measuring pressures or partial vacuums to the tolerances given in Table 1. They may consist of Bourdon gages, pressure manometers, electronic pressure transducers, or any other device capable of measuring pressures, or partial vacuums to the stated tolerances. If separate devices are used to measure the chamber pressure and back pressure, the devices must be calibrated simultaneously and against the same pressure source. Since the chamber pressure and back pressure are the pressures taken at the mid-height of the specimen, it may be necessary to adjust the calibration of the devices to reflect the hydraulic head of fluid in the chamber and back pressure control systems (see Fig. 2).

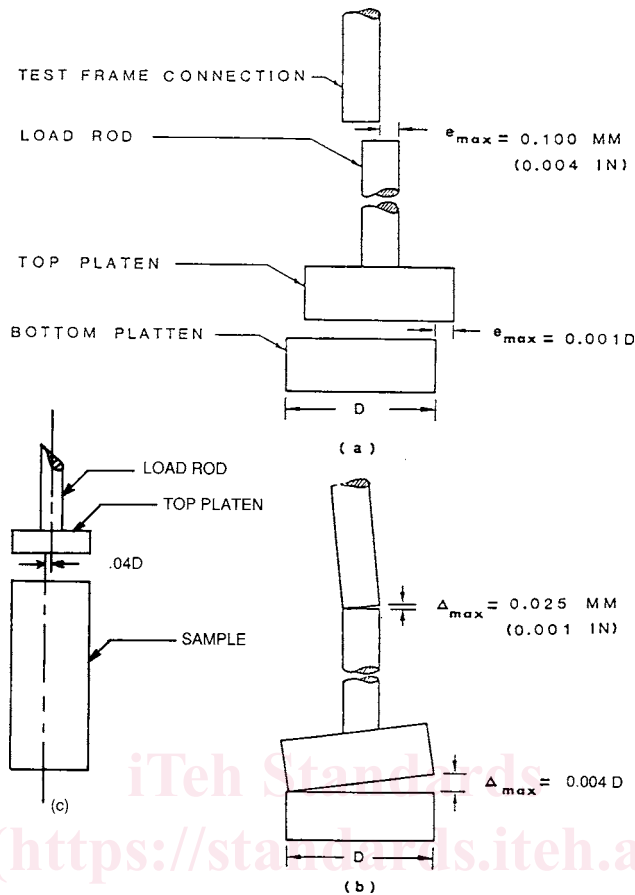

FIG. 5.6 Limits on Acceptable Platen and Load-Ring Piston Alignment: (a)-e Eccentricity, (b)-p Parallelism, (c)-e Eccentricity between Top Platen and Specimen

6.4.6

ASTM D3999-11

6.5.6 Pore-Water Pressure Measurement Device—The specimen pore-water pressure shall also be measured to the tolerances given in Table 1. During cyclic loading on a saturated specimen the pore-water pressure shall be measured in such a manner that as little water as possible is allowed to go into or out of the specimen. To achieve this requirement a very stiff electronic pressure transducer must be used. With an electronic pressure transducer the pore-water pressure is read directly. The measuring device shall have a rigidity of all the assembled parts of the pore-water pressure measurement system relative to the total volume of the specimen satisfying the following requirement:

$$\frac{(\Delta V/V)}{\Delta \sigma} < 3.2 \times 10^{-6} \text{ m}^2/\text{kN} \quad (2.2 \times 10^{-5} \text{ in.}^2/\text{lb}) \quad (1)$$

$$\frac{(\Delta V/V)}{\Delta \sigma} < 3.2 \times 10^{-6} \text{ m}^2/\text{kN} \quad (2.2 \times 10^{-5} \text{ in.}^2/\text{lb}) \quad (1)$$

D3999-11\_2

$\Delta u$

where:

$\Delta V$  = change in volume of the pore-water measurement system due to a pore pressure change,  $\text{in.}\cdot\text{mm}^3$  ( $\text{mm}^3$ ),

$V$  = the total volume of the specimen,  $\text{in.}\cdot\text{mm}^3$  ( $\text{mm}^3$ ), and

$\delta \sigma$  = the change in pore pressure,  $\text{psi}$  ( $\text{kPa}$ ),  $\text{kPa}$  ( $\text{psi}$ ).

$\Delta u$

NOTE 2—To meet the rigidity requirement, tubing between the specimen and the measuring device should be short and thick walled with small bores. Thermoplastic, copper, and stainless steel tubing have been used successfully in many laboratories.

6.4.76.5.7 Volume Change Measurement Device—The volume of water entering or leaving the specimen shall be measured with an accuracy of within  $\pm 0.05\%$  of the total volume of the specimen. The volume measuring device is usually a burette but may be any other device meeting the accuracy requirement. The device must be able to withstand the maximum chamber pressure.

6.5



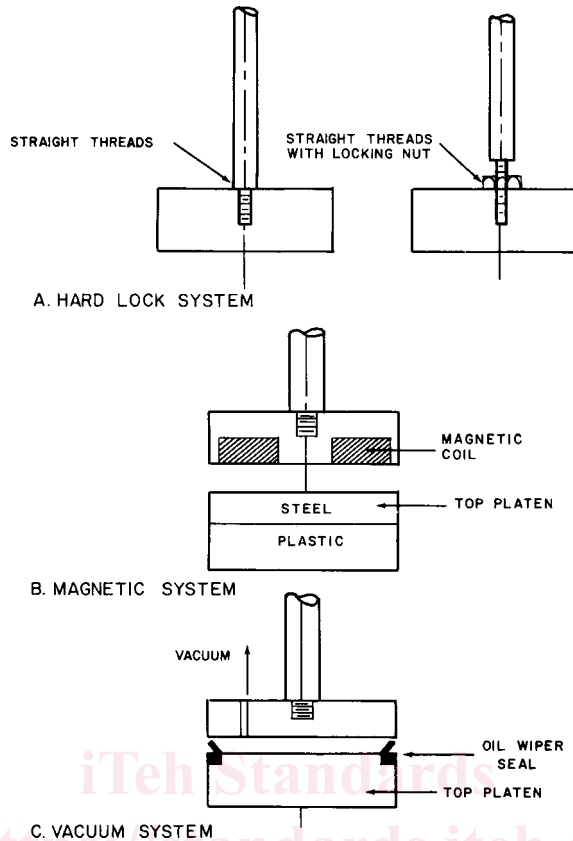

FIG. 6.7 Typical Top Platen Connections

**6.6 Specimen Cap and Base**—The specimen cap and base shall be designed to provide drainage from both ends of the specimen. They shall be constructed of a rigid, noncorrosive, impermeable material, and each shall, except for the drainage provision, have a circular plane surface of contact with the porous discs and a circular cross section. The weight of the specimen cap and top porous disc shall be less than 0.5 % of the applied axial load at failure as determined from an undrained static triaxial test. The diameter of the cap and base shall be equal to the initial diameter of the specimen. The specimen base shall be connected to the triaxial compression chamber to prevent lateral motion or tilting, and the specimen cap shall be designed such that eccentricity of the piston-to-cap contact relative to the vertical axis of the specimen does not exceed  $0.04 D$  ( $D$  = diameter of specimen) as shown in Fig. 5 Fig. 6(c). The cylindrical surface of the specimen base and cap that contacts the membrane to form a seal shall be smooth and free of scratches.

6.6

**6.7 Porous Discs**—The specimen shall be separated from the specimen cap and base by rigid porous discs fastened to the specimen cap and base of a diameter equal to that of the specimen. The coefficient of permeability of the discs shall be approximately equal to that of fine sand  $1 \times 10^{-3}$  mm/s. The specimen shall be separated from the specimen cap and base by rigid porous discs embedded into or fastened onto the specimen cap and base of a diameter equal to that of the specimen using epoxy (carefully avoiding the area around the drainage conduits of the platen) or screws in the case of sintered metal porous discs. The coefficient of permeability of the discs shall be approximately equal to that of fine sand  $1 \times 10^{-3}$  mm/s ( $3.9 \times 10^{-5}$  in./s). The discs shall be regularly checked by passing air or water under pressure through them to determine whether they have become clogged. Care must be taken to ensure that the porous elements of the end platens are open sufficiently so as not to impede drainage or pore water movement from specimen into the volume change or pore pressure measuring devices, and with openings sufficiently fine to prevent movement of fines out of the specimen. **Note 3**—Filter-paper discs of a diameter equal to that of the specimen may not be placed between the porous discs and specimen to avoid clogging of the porous discs when measuring moduli values on stiff specimens.

6.7

**6.8 Filter Papers**—When determining moduli values of stiff specimens, filter-paper discs of a diameter equal to that of the specimen may not be placed between the porous discs and specimen to minimize clogging of the porous discs to avoid inclusion of a soft layer into the system. Filter papers may be used as long as they do not cause the system to go out of compliance (Note 2).

**6.9 Filter-Paper Strips**—Filter-paper strips are used by many laboratories to decrease the time required for testing. If filter strips are used, they shall be of a type that does not dissolve in water. The coefficient or permeability of the filter paper shall not be less than  $1 \times 10^{-4}$  mm/s ( $3.9 \times 10^{-6}$  in./s) for a normal pressure of 550 kPa (80 psi). To avoid hoop tension, filter strips should cover

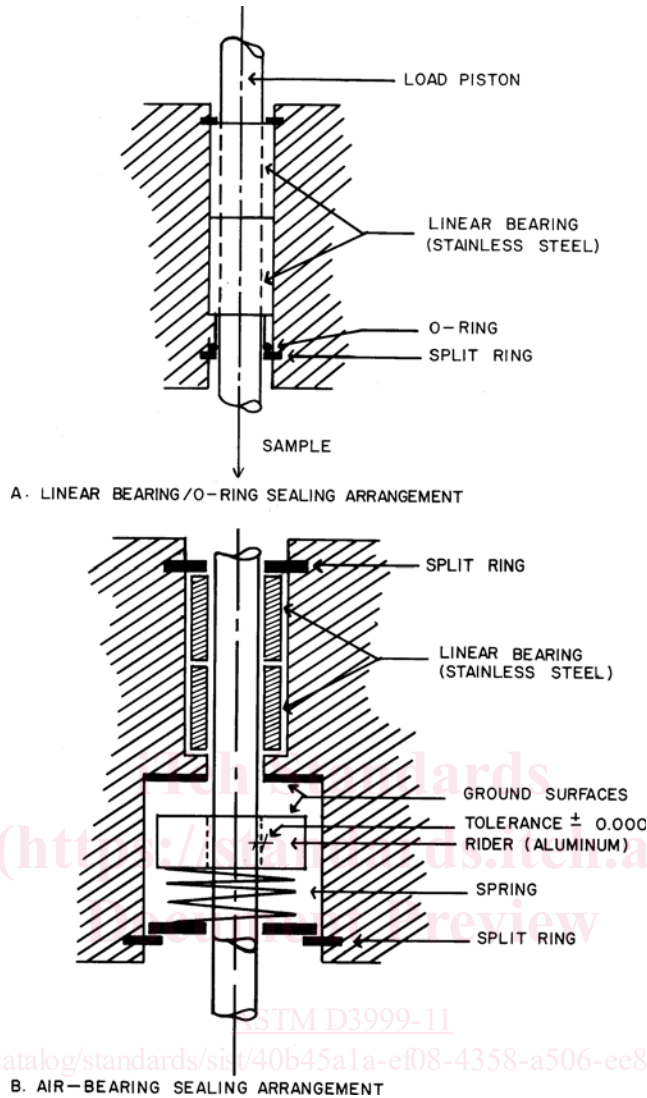

FIG. 8 Typical Cyclic Triaxial Piston Sealing Arrangements

no more than 50 % of the specimen periphery. Note 4—The filter paper given in Footnote 6 has been found to meet the permeability and durability requirements:

6.8

6.10 *Rubber Membrane*—The rubber membrane used to encase the specimen shall provide reliable protection against leakage. To check a membrane for leakage, the membrane shall be placed around a cylindrical form, sealed at both ends with rubber O-rings, subjected to a small air pressure on the inside, and immersed in water. If air bubbles appear from any point on the membrane it shall be rejected. To offer minimum restraint to the specimen, the unstretched membrane diameter shall be between 90 and 95 % of that of the specimen. The membrane thickness shall not exceed 1 % of the diameter of the specimen. The membrane shall be sealed to the specimen cap and base with rubber O-rings for which the unstressed inside diameter is between 75 and 85 % of the diameter of the cap and base, or by other means that will provide a positive seal.

6.9

6.11 *Valves*—Changes in volume due to opening and closing valves may result in inaccurate volume change and pore-water pressure measurements. For this reason, valves in the specimen drainage system shall be of the type that produces minimum volume changes due to their operation. A valve may be assumed to produce minimum volume change if opening or closing the valve in a closed, saturated pore-water pressure system does not induce a pressure change of greater than 0.7 kPa (0.1 psi). All valves must be capable of withstanding applied pressures without leakage.

NOTE 5—Ball valves have been found to provide minimum volume-change characteristics; however, any other type of valve having the required volume-change characteristics may be used.

6.106.12 *Specimen-Size Measurement Devices*—Devices used to determine the height and diameter of the specimen shall measure the respective dimensions to within 0.1 % of the total dimension and shall be constructed such that their use will not disturb the specimen.